

Air Handling



**TECHNICAL
CATALOGUE**

02/2025

 **RDZ**
You Feel, We Care



You Feel, We Care

*is our new tagline
and contains a renewed promise:
to work every day
with commitment and passion
while offering **tangible benefits**.*

*And we do this by developing systems
which are able to ensure
comfort and health
as well as a pleasant living space.*

*We continue to follow the principles
that have always inspired us:
the use of the **best materials**,
the research for **advanced technologies**,
and a **specialized service** for design,
technical assistance and training.*

*These are the same reasons
that guided us in
identifying the
perfect comfort system.*

*In our solution four elements
(surface heating/cooling, air handling,
temperature control, heat pumps)
interact synergistically
to spread in every room
the **ideal living conditions**,
in which our skin can perceive
a unique **feeling of wellbeing**.*



Table of Contents

MECHANICAL VENTILATION WITH HEAT RECOVERY

PAGE 6

WHR decentralized MVHR units

PAGE 8

CHR and Reflair ductable MVHR units

PAGE 10

WHR vertical ductable MVHR units

PAGE 18

WHRI recessed ductable MVHR units

PAGE 22

MVHR selection guide

PAGE 28

MVHR units for commercial application

PAGE 30

AIR DEHUMIDIFICATION

PAGE 54

RNW dehumidifiers

PAGE 56

RNW selection guide

PAGE 67

DWF dehumidifiers without fan

PAGE 68

DA dehumidifiers

PAGE 72

FRESH AIR VENTILATION WITH DEHUMIDIFICATION

PAGE 78

AHU for residential application

PAGE 80

AHU Selection guide

PAGE 93

AHU for commercial application

PAGE 94

COMPLEMENTS FOR AIR HANDLING SYSTEMS**PAGE 100***Control systems***PAGE 101***Siphons***PAGE 110***Flow meters***PAGE 111***Modulating valves***PAGE 112***Duct heaters RE-S and RE-M series***PAGE 113***Water batteries BA-C series***PAGE 117***Water exchangers BA-P series***PAGE 120****AIR DISTRIBUTION SYSTEMS****PAGE 124***Main air ductwork**Flex system***PAGE 130***EPE system***PAGE 136***Room air ductwork**Duo White system***PAGE 138***LowAir systems***PAGE 151***Vents and air grills***PAGE 158**

FRESH AIR AND HUMIDITY CONTROL

Two requirements for healthy, comfortable and energy efficient buildings

Today, more than ever before, the quality of life and, consequently, the state of well-being of people in workplaces, leisure and homes, has become a priority from a design point of view. Satisfying the thermo-hygrometric wellbeing of the occupants of an environment requires the monitoring and control of different parameters, such as the temperature and humidity of the air, the concentration of pollutants, such as CO₂, volatile organic compounds (VOC), formaldehyde, airborne particulate, allergens, etc.

Air quality control is particularly important in commercial spaces, offices, and energy-efficient homes, built according to modern construction standards, characterised by highly thermally insulated building envelopes and highly airtight windows and doors, which drastically reduce infiltration rates typical of older buildings. Moreover, inadequate ventilation of rooms, entrusted solely to the opening of windows, can cause not only poor air quality, but also the formation of surface condensation and mould that is harmful not only to human health but also to the building.

RDZ, which has always been dedicated to satisfying people's thermo-hygrometric comfort, has developed air treatment machines that ensure a high level of healthiness in rooms.

They are subdivided into

- controlled mechanical ventilation with heat recovery (MVHR)
- fresh air ventilation with dehumidification

MECHANICAL VENTILATION WITH HEAT RECOVERY (MVHR)

These machines allow the exchange of room air with external air in a controlled manner and minimising energy waste; the external air, suitably filtered, is introduced into the room while the stale room air is expelled outside.

The characterising element of these machines, apart of course from the inlet and exhaust fans and the filters, is the heat exchanger, which makes it possible to recover the energy stored in the exhausted air in favour of that to be introduced into the environment, with recovery efficiencies that, under certain conditions, reach and exceed 90%.

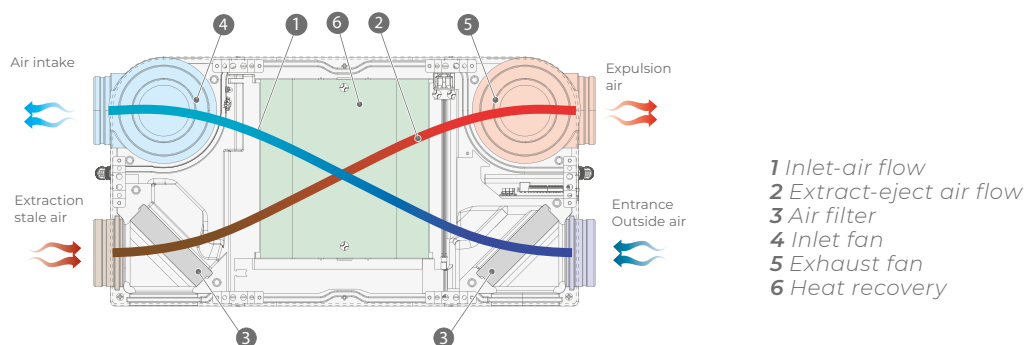

Operating principle of a dual-flow MVHR machine

MVHR machines, in addition to the basic functions, are equipped with additional functions, such as free cooling or boost, which allow the heat exchanger to be by-passed when indoor/outdoor thermal conditions are favourable or to maximise the flow rate of treated air to increase the effectiveness of room washing at particularly crowded times, respectively. They can also be combined with external water coils, to supply neutral temperature air into the room or to supplement the heating/cooling capacity supplied by the air conditioning system.

DEHUMIDIFIERS

These machines treat the ambient air to keep its humidity level under control. This is also necessary to ensure that radiant systems operating in cooling can achieve high specific outputs.

In addition to the performance of the fan and air filter, the machines differ in the moisture content they are able to remove from the environment in the unit of time (typically litres/hour of condensate). They are also equipped with (internal) water coils in order to integrate the heating/cooling power delivered by the radiant system.

AHU HANDLING UNITS (UC)

These machines combine the functions of controlled mechanical ventilation (MVHR), dehumidification and sensible heat supply in a single device.

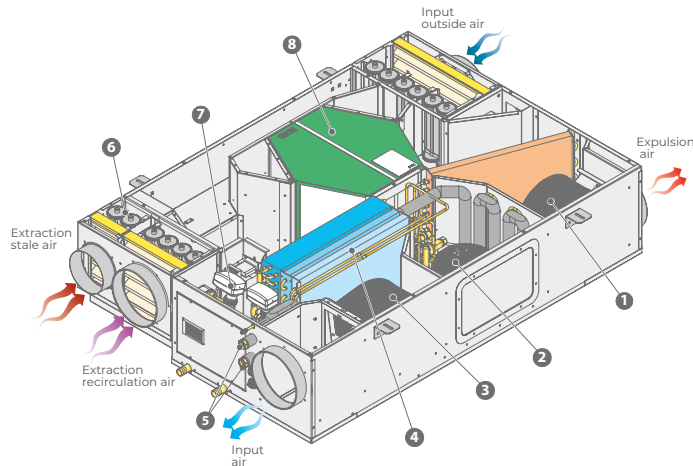

- 1 Exhaust fan
- 2 Compressor
- 3 Inlet fan
- 4 Heat exchange coils
- 5 Hydraulic connections
- 6 Dampers
- 7 Integration modulating valves
- 8 Heat exchanger

Operating principle of an air handling unit

They differ in fan and air filter performance, in the moisture content they are able to remove from the environment in the unit of time, and in the rate of energy recovery. They are also equipped with (internal) water batteries for stabilising the internal refrigeration circuit and for integrating the heating/cooling power supplied by the radiant system.

ROOM AIR DUCTWORK

The MVHR and UC units (simple recirculating dehumidifiers are excluded), although they constitute the heart of the air exchange/treatment system, they require a network of distribution ducts and terminal elements (supply air, room air intake, external air intake, expulsion) in order to guarantee correct operating efficiency. The distribution system must be suitably sized to guarantee the correct air flow rates and velocities and for effective room cleaning.

To help designers, RDZ offers different types of distribution systems in its catalogue for domestic and small tertiary applications:

- **Main pipelines of the distribution:**
 - ducts of the flexible type (FLEX system), fitted with hygienic treatments to ensure high air quality, preventing the spread of mould and bacteria, and acoustic insulation if necessary;
 - rigid type ducts in galvanised steel,
 - condotti di tipo rigido in polietilene espanso (sistema EPE),
- **Rigid type ducts in expanded polyethylene (EPE system),**
 - flexible high-density polyethylene ducts with circular cross-section (DUO WHITE system), with associated distribution plenums,
 - flexible polypropylene ducts with a semi-oval cross-section (Lowair system), with relative distribution plenums.

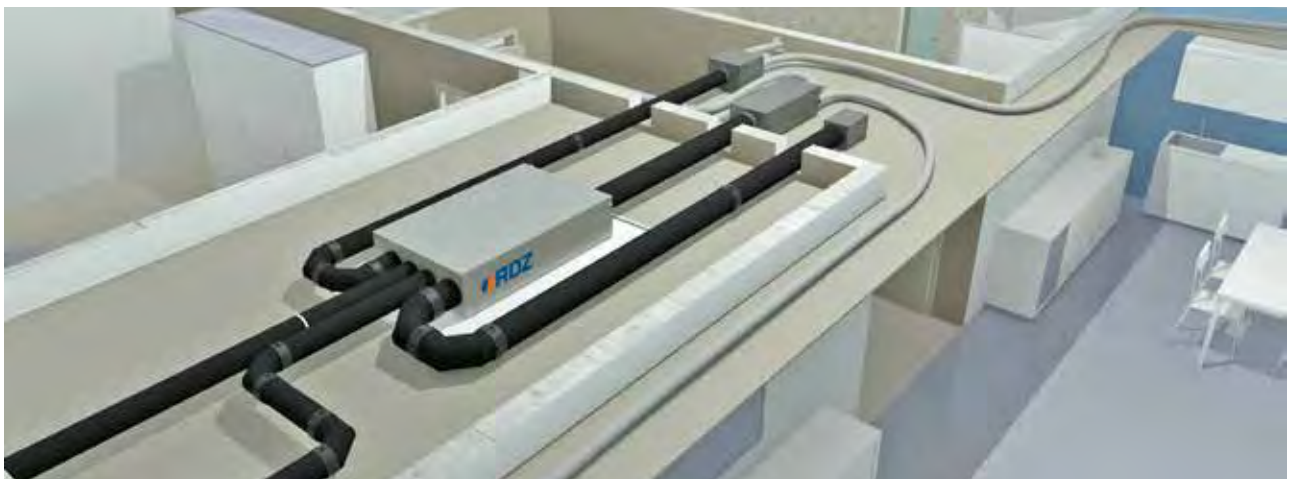

Example of air distribution



Mechanical ventilation with heat recovery





Fresh, clean air **without energy waste**

Comfort at home, in office or in any other living or working space also depends on the quality of the air we breathe. Air that shall be healthy and rich in oxygen to make us feel good.

Our **mechanical ventilation with heat recovery units** are designed to provide specific quantities of **fresh and clean air** while expelling stale air. The energy from the extracted polluted air is recovered by a heat exchanger integrated in the unit and transferred to the new clear air supplied. This preserves indoor thermal comfort and reduces heating and cooling costs. In commercial buildings and new modern well-insulated houses, pollutants such as VOCs (volatile organic compounds), formaldehyde, indoor particulate matter and others remain trapped inside the rooms to the detriment of the health and well-being of the occupants. This is why we believe it is essential to equip every building with a mechanical ventilation system that guarantees an effective and constant air renewal.

ADVANTAGES OF MECHANICAL VENTILATION SYSTEMS WITH HEAT RECOVERY:

-  **CLEAN AIR AND COMFORT ALL YEAR ROUND**
-  **ROOMS HEALTINESS AND HYGIENE**
-  **ENERGY SAVING THANKS TO HEAT RECOVERY AND FREE-COOLING**
-  **PRESERVATION OF THE VALUE OF BUILDING**
-  **EASY SYSTEM INSTALLATION**

WHR 62 PLUS

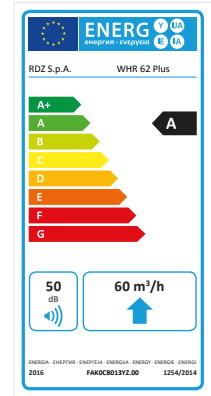

MODEL	CODE
WHR 62 Plus	7045227

Decentralized mechanical ventilation unit with alternating pushpull flows, characterized by low noise and equipped with ceramic exchanger offering efficiency up to 90%. It is equipped with double G3 filters (ISO coarse 50%), Ø 160 mm ducting variable in length from 250 mm to 400 mm, tilting front panel to avoid air return, visual and sound indicators for input reception and filter cleaning. Remote control with display screen.

FEATURES

Voltage at 50Hz [V]	Max efficiency	Speed	Flow rate m³/h	Power W	Noise at 3 m dB(A)
220-240	93%	Night	10	3.9	4
		1	20	4.2	9
		2	40	5.5	21
		3	60	6.7	30

DIMENSIONS

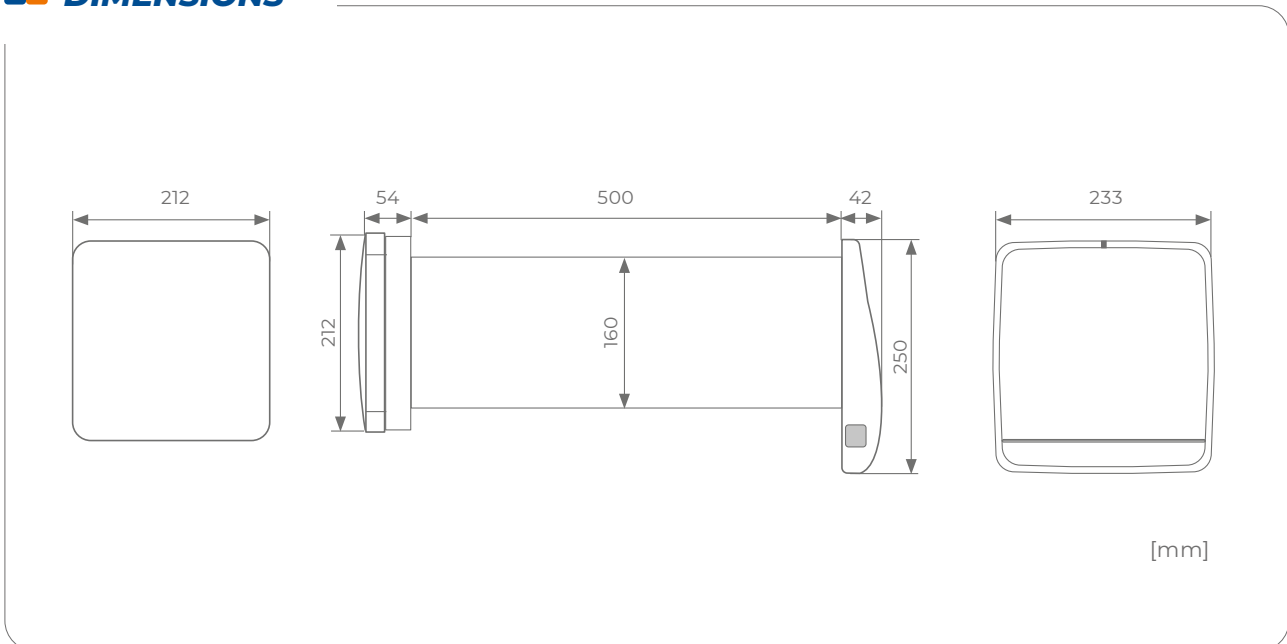



INSTALLATION

- Vertical wall-mounted
- Slope 1-2%



Unit weight

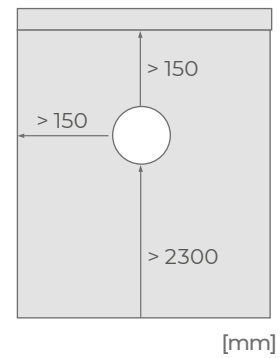
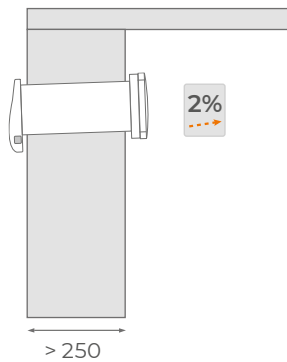

OPERATION

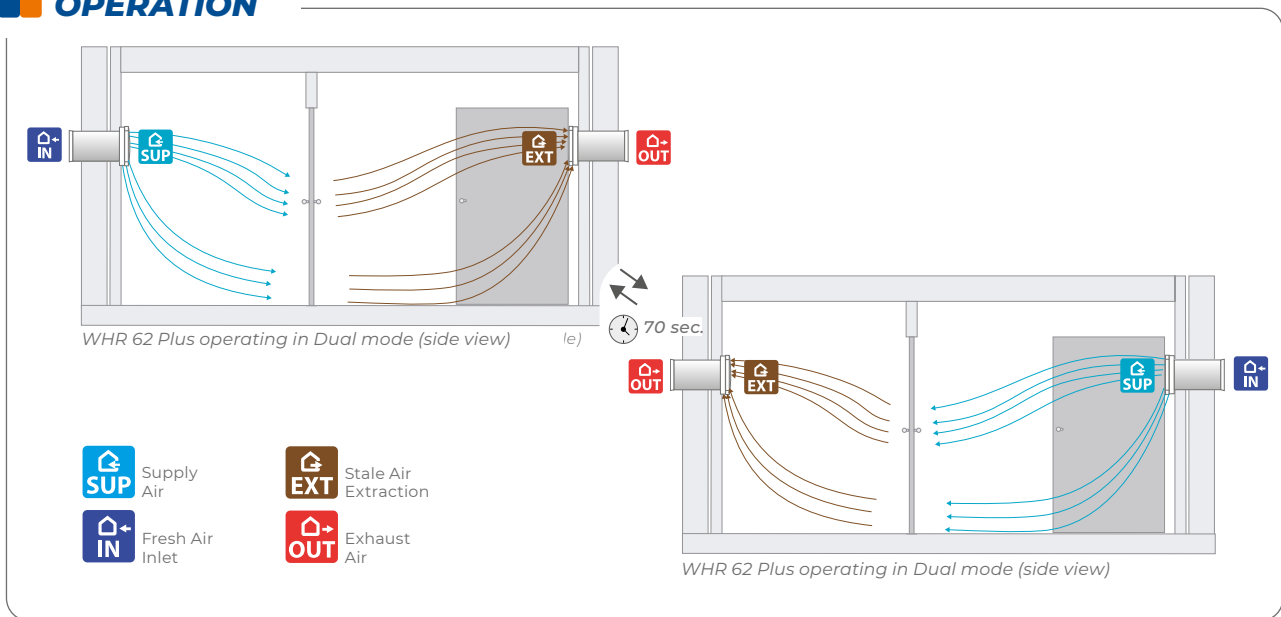

COMPLEMENTS

WHR 62-RC

Remote control with display screen. It allows the management of one or more WHR 62 units connected in series.

It allow to manage the following functions:

- Selection of the fan speed;
- Selection of the operativity mode (air extraction, air supply, combined);
- Setting of night mode;
- Time scheduled air extraction mode;
- Setting of relative humidity threshold;
- Reset of filters alarm;
- Batteries: 2xCR2032 3V.



CODE

7045226

WHR 62-T160

Duct for WHR 62 needed whether the length of the standard equipped pipe is not enough



PIPE SIZE

Ø160x700 mm

CODE

7045208

KIT Filters WHR 62 PLUS

4 inlet/outlet filters ISO Coarse 50%, Ø160 mm.



SIZE

DN 160

CODE

7044101



**ALSO IN
ENTHALPIC
VERSION
(ERV)**

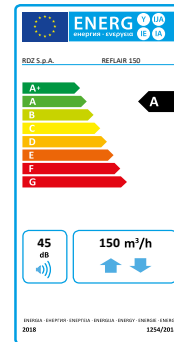

with control:
Manual, Clock, Central
demand

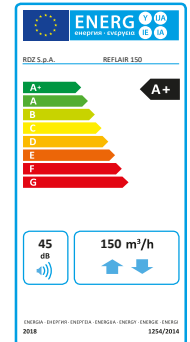

with control: Local demand
(ambient probes of air
quality)

MODEL	CODE
REFLAIR 150	70RFL00150
REFLAIR 150 ERV	70RFL0E150

Reflair is an high-efficiency ductable mechanical ventilation unit with heat recovery, designed for residential use. It can be equipped with either a sensible or enthalpy heat recovery unit. It can be installed either in the false ceiling or on the wall. Adjustable and configurable connections ensure a constant pressure drop and reduce the number of connections required. The construction in sintered expanded polypropylene thermally insulates the internal components and makes the unit extremely light. Thanks to its compact dimensions, it can be installed in spaces of reduced height. Reflair can be managed via the Air Control or Air Speed control panels or integrated into the CoRe regulation system.

FEATURES

- Nominal air flow rate: 105 m³/h
- Max air flow rate: 150 m³/h
- Filter Iso Coarse 65% (G4)

TECHNICAL DATA

- Size l x h x d: 1100x240x585 mm
- Sound power: 45 dB(A)
- Max. electrical power: 115 W
- Elect. power supply 230 Vac - 50/60 Hz

CONNECTIONS AND FILTERS

- Air duct connections Ø 160 mm
- Condensate drain Ø 13 mm

-  Supply Air
 -  Fresh Air Inlet
 -  Stale Air Extraction
 -  Exhaust Air
-  ISO Coarse e(PM10) min ≤ 50% (Hairs)

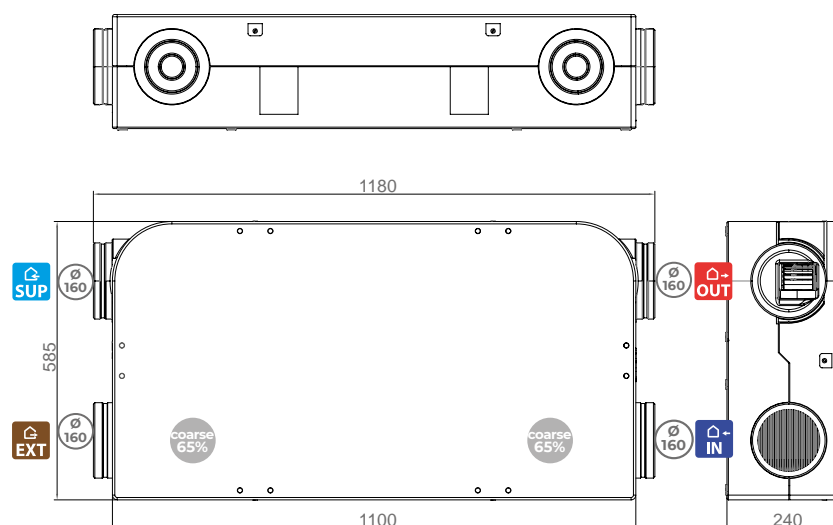



REFLAIR AERAILIC CONFIGURATION

CEILING INSTALLATION

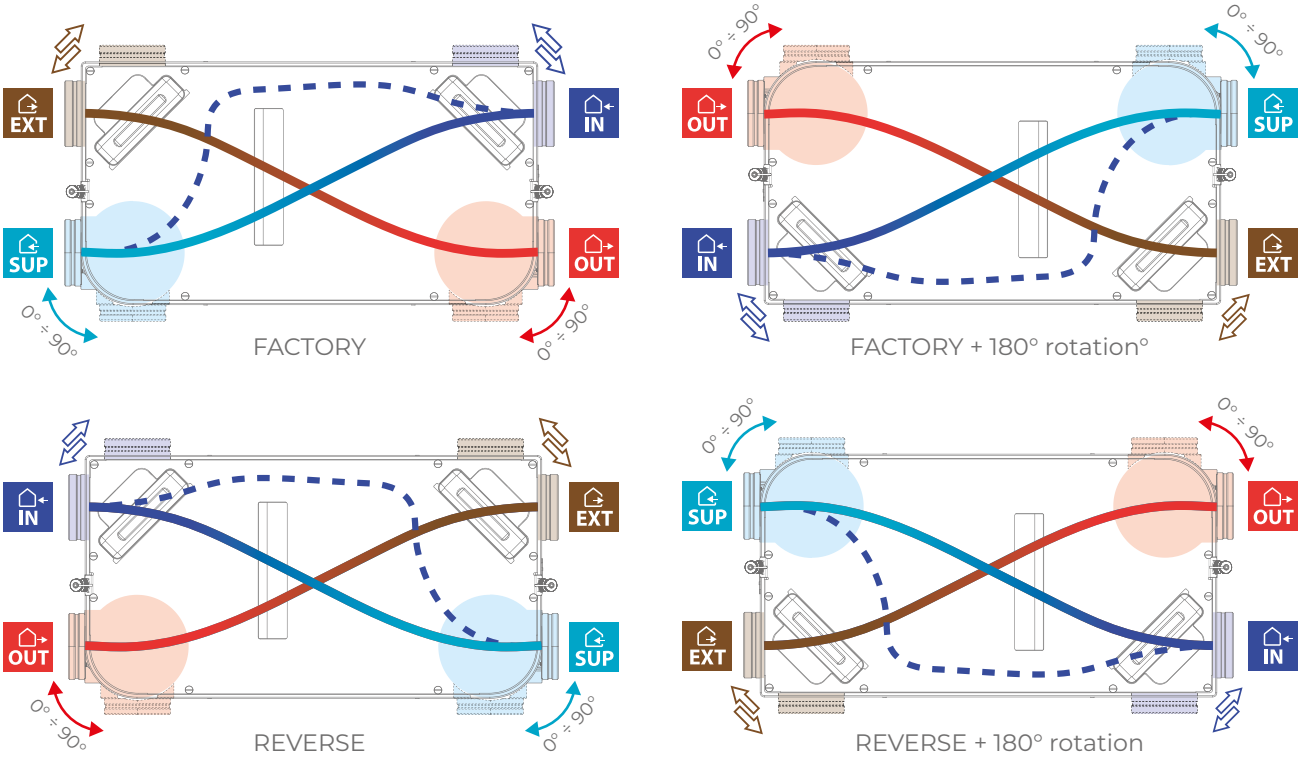

WALL INSTALLATION

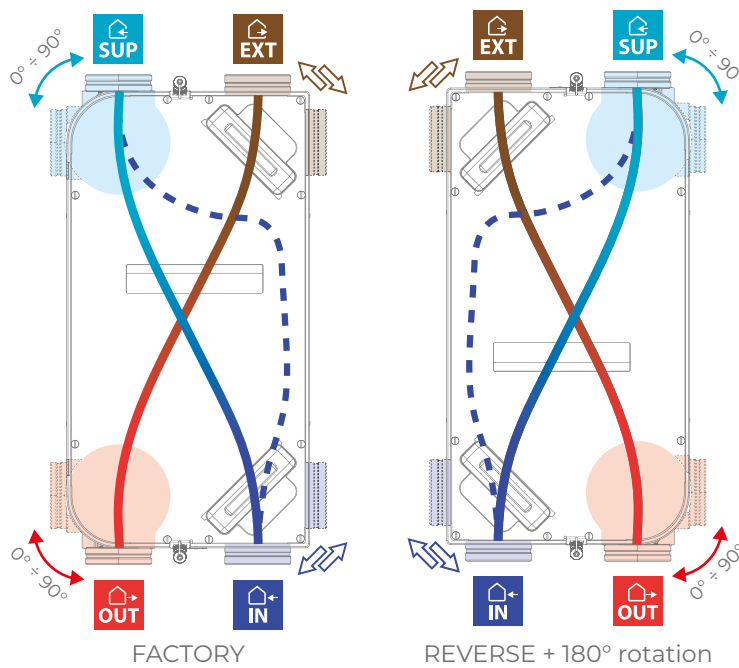

INSTALLATION

- Horizontal ceiling-mounted
- Vertical wall-mounted
- Slope 2%

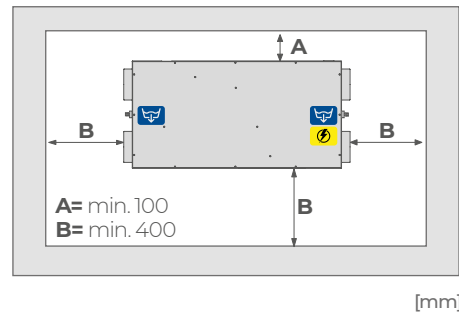
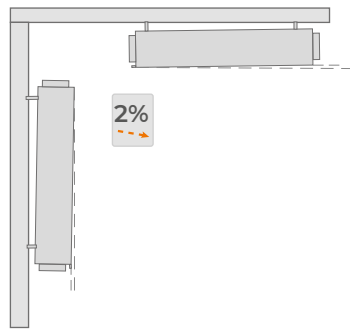

PERFORMANCE

Air flow m ³ /h	Pressure Pa	Electric cons. W
60	100	20
85	100	27
110	100	33
150	100	48

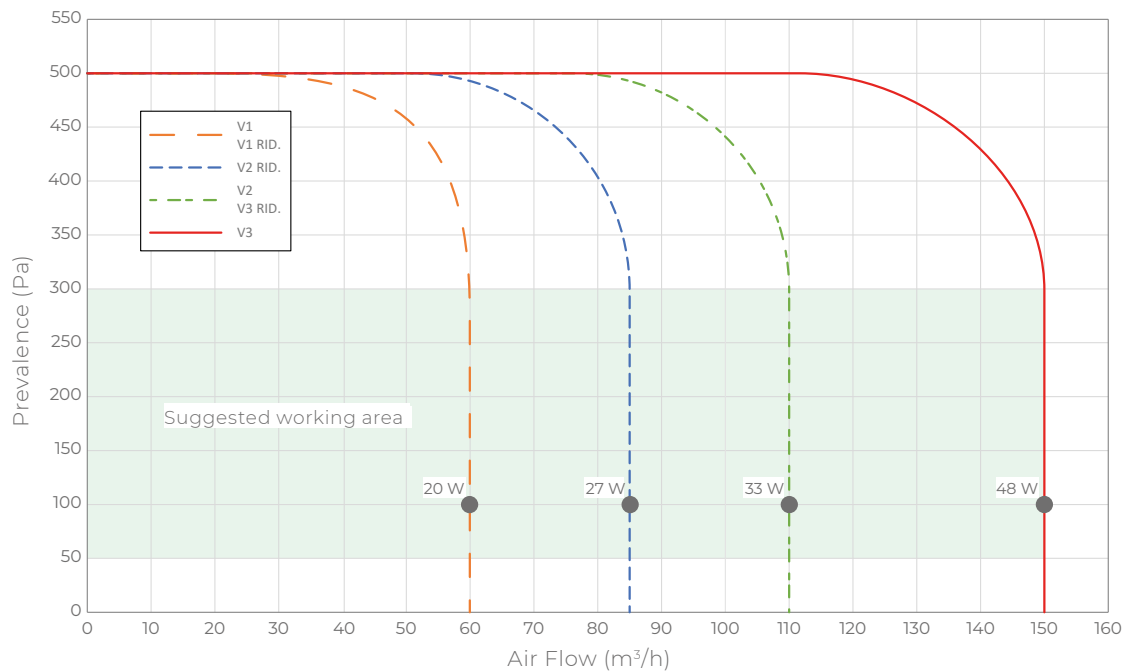

COMPLEMENTS

	Control			Siphons		Preheating		Post treatment
Name	CORE AIR SPEED	CORE AIR CONTROL	KNX-UTA Interface	SF-M 13 Condensate drain kit	SF-P N Sifowall	RE-S 05-125 Electrical resistance on/off	RE-M 05-125 Electrical resistance 0-10V	BA-P 6 / 10 Water exchanger
Page	88	89	106	110	110	113	115	120

REFLAIR 250



ALSO IN ENTHALPIC VERSION (ERV)

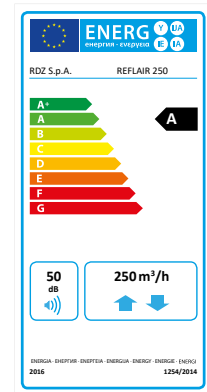

MODEL	CODE
REFLAIR 250	70RFLO0250
REFLAIR 250 ERV	70RFLOE250

Reflair is an high-efficiency ductable mechanical ventilation unit with heat recovery, designed for residential use. It can be equipped with either a sensible or enthalpy heat recovery unit. It can be installed either in the false ceiling or on the wall. Adjustable and configurable connections ensure a constant pressure drop and reduce the number of connections required. The construction in sintered expanded polypropylene thermally insulates the internal components and makes the unit extremely light. Thanks to its compact dimensions, it can be installed in spaces of reduced height. Reflair can be managed via the Air Control or Air Speed control panels or integrated into the CoRe regulation system.

FEATURES

- Nominal air flow rate: 175 m³/h
- Max air flow rate: 250 m³/h
- Filter Iso Coarse 65% (G4)

TECHNICAL DATA

- Size l x h x d: 1100x240x585 mm
- Sound power: 50 dB(A)
- Max. electrical power: 165 W
- Elect. power supply 230 Vac - 50/60 Hz

CONNECTIONS AND FILTERS

- Air duct connections Ø 160 mm
- Condensate drain Ø 13 mm

-  Supply Air
 -  Fresh Air Inlet
 -  Stale Air Extraction
 -  Exhaust Air
-  ISO Coarse e(PM10) min ≤ 50% (Hairs)

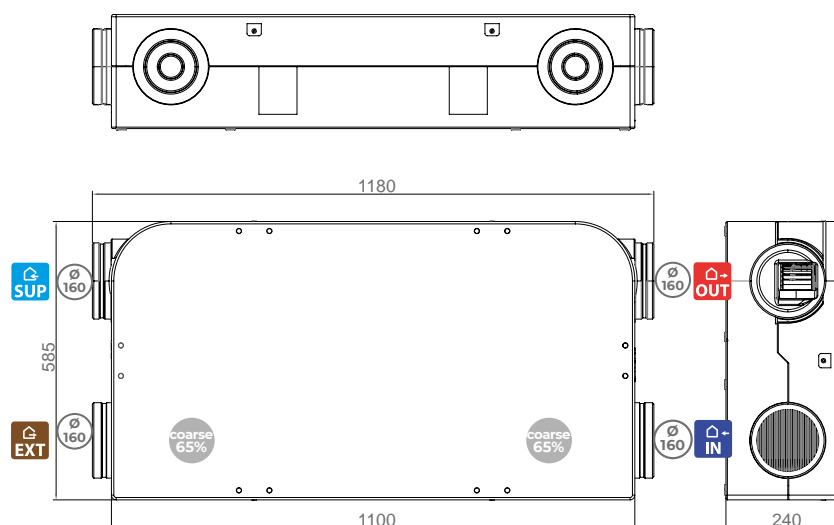



REFLAIR AERAILIC CONFIGURATION

CEILING INSTALLATION

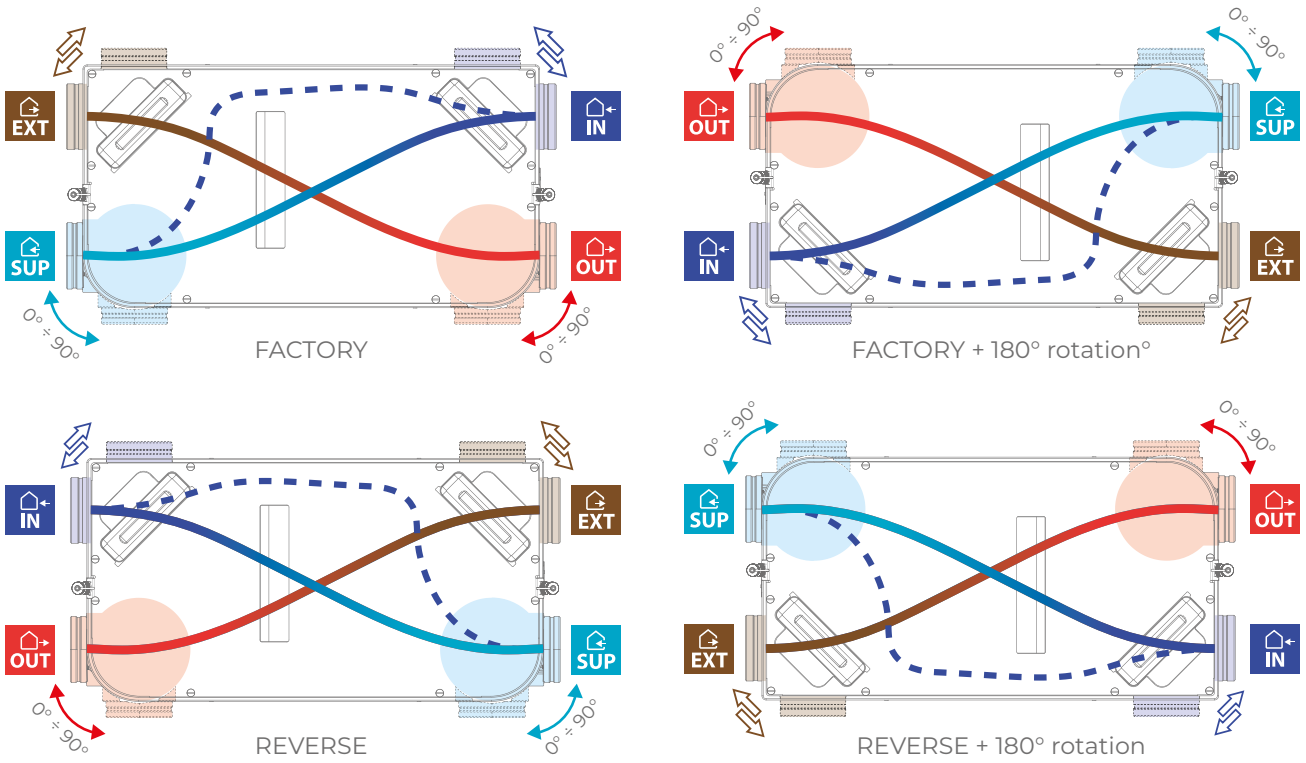

WALL INSTALLATION

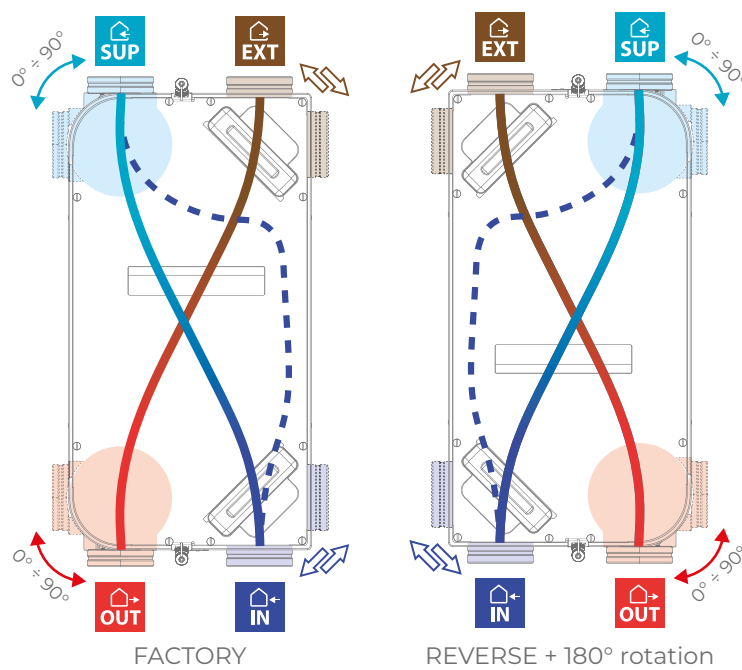

INSTALLATION

- Horizontal ceiling-mounted
- Vertical wall-mounted
- Slope 2%

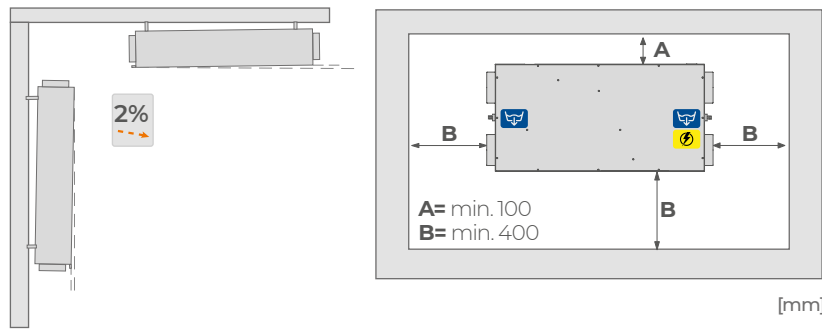

PERFORMANCE

Air flow m ³ /h	Pressure Pa	Electric cons. W
60	100	20
85	100	27
110	100	33
180	100	63
250	100	124

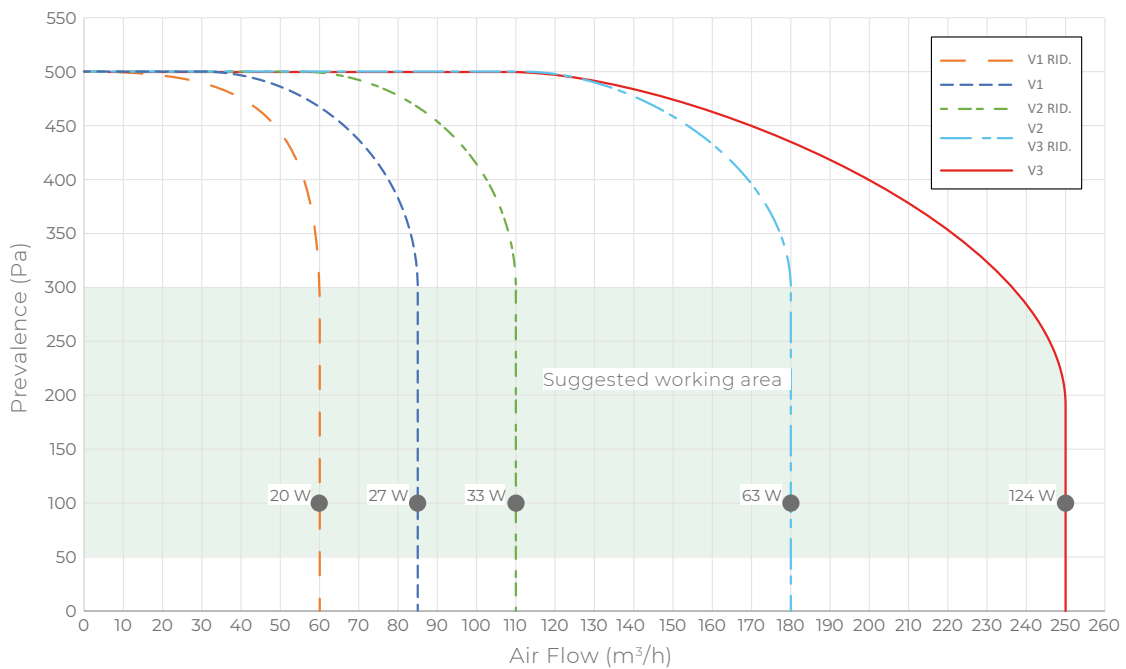

COMPLEMENTS

	Control			Siphons		Preheating		Post treatment
Name	CORE AIR SPEED	CORE AIR CONTROL	KNX-UTA Interface	SF-M 13 Condensate drain kit	SF-P N Sifowall	RE-S 075-160 Electrical resistance on/off	RE-M 075-160 Electrical resistance 0-10V	BA-P 6 / 10 Water exchanger
Page	102	103	106	110	110	113	115	120

CHR 400 CORE

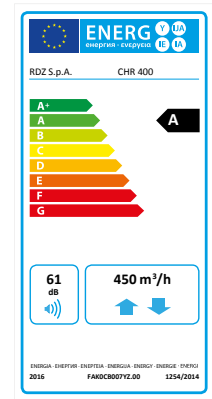

MODEL	CODE
CHR 400 Core	7045509

Low profile ceiling-mounted horizontal mechanical ventilation unit with double high efficiency (~90%) polystyrene heat exchanger. Made with pre-painted galvanized steel frame and internal thermal-acoustic insulation, it is equipped with constant flow rate EC motors, by-pass for free-cooling, and four NTC sensors. Antifreeze function and dirty filter detectors included. The unit is predisposed for doubling and/or mirroring the spigots both for the indoor air and for the outdoor air. It can be managed by digital input and/or control panel, or by using the RDZ electronic control unit via ModBus. CHR 400 can be combined with the DWF 400 dehumidification module. Two condensate drain kits or similar accessories are compulsory (SF-M or SF-P N).

FEATURES

- Nominal air flow rate: 400 m³/h with 300 Pa
- Filter external air inlet: ISO Coarse 50% (G2) + ISO ePM10 65% (M5)
- Stale air extraction filter: ISO Coarse 65% (G4)
- Constant flow rate EC motors
- Stainless steel condensate collection tray

TECHNICAL DATA

- Size l x h x d: 1375x271x860 mm
- Sound pressure level at 1 m: 50 dB(A)
- 4 NTC sensors
- Max. electrical power: 290 W
- Elect. power supply 230 Vac - 50/60 Hz

CONNECTIONS AND FILTERS

- Air duct connections Ø 200 mm
- 2 condensate drain Ø 14 mm

- Supply Air
- Fresh Air Inlet
- Stale Air Extraction
- Exhaust Air
- ISO Coarse e(PM10) min ≤ 50% (Hairs)
- ISO ePM₁₀ e(PM10) min ≥ 50% (Pollen, sand and dust)

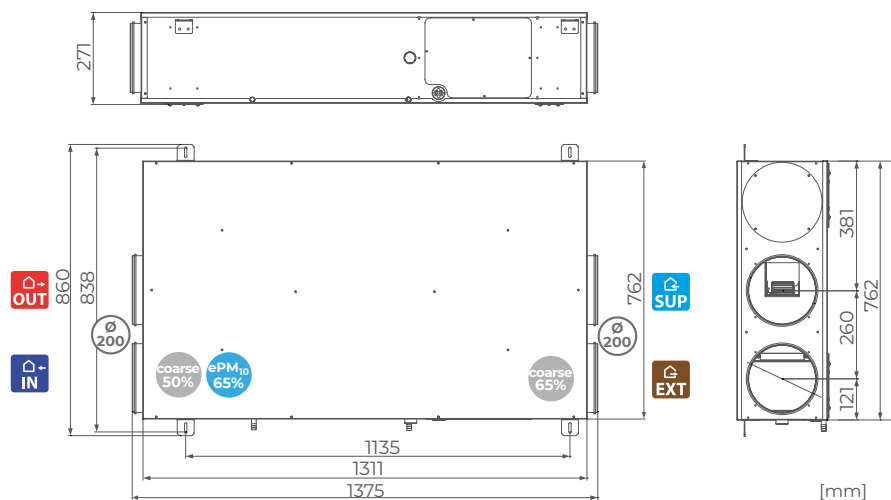



INSTALLATION

- Horizontal ceiling-mounted
- Slope 2%

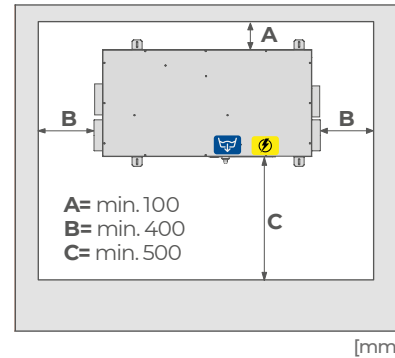
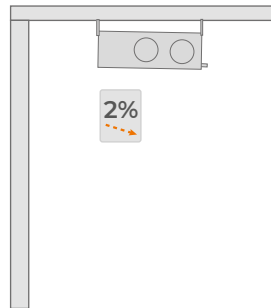

PERFORMANCE

Air flow m ³ /h	Pressure Pa	Electric cons. W
100	550	180
200	480	210
400	300	280
450	130	290

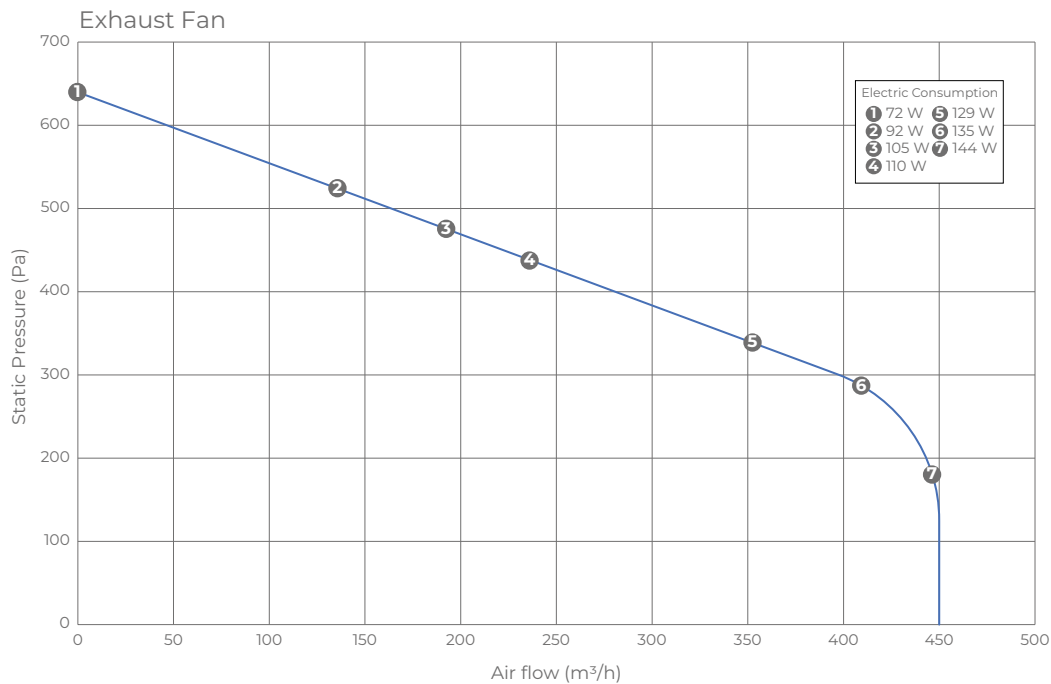

COMPLEMENTS

	Control			Siphons		Preheating		Post treatment
Name	CORE AIR SPEED	CORE AIR CONTROL	KNX-UTA Interface	SF-M 13 Condensate drain kit	SF-P N Sifowall	RE-S 15-200 Electrical resistance on/off	RE-M 15-200 Electrical resistance 0-10V	BA-P 6 / 10 Water exchanger
Page	102	103	106	110	110	113	115	120

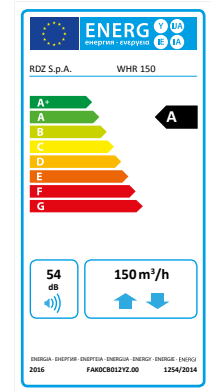

MODEL	CODE
WHR 150	7045627

Vertical wall-mounted controlled mechanical ventilation unit, with high-efficiency (~90%) countercurrent heat recovery system, made with a prepainted steel plate frame and internal thermo-acoustic insulation. The unit is equipped with two centrifugal fans with constant flow EC motors, 4 NTC type temperature sensors. Management via RDZ electronic control, digital inputs or room control panel. 2 siphons required (SF-M or SF-P N).

FEATURES

- Boost air flow rate: 150 m³/h – 150 Pa
- Filter external air inlet: ISO ePM10 50%
- Stale air extraction filter: ISO ePM10 50%
- Constant flow rate EC motors
- Stainless steel condensate collection tray

TECHNICAL DATA

- Size lxhxd: 630x640x400 mm
- Sound pressure level: 51 dB(A)
- 4 NTC sensors
- Max. electrical power: 160 W
- Elect. power supply 230 Vac - 50/60 Hz

CONNECTIONS AND FILTERS

- Air duct connections Ø 125 mm
- 2 condensate drain Ø 14 mm



ISO ePM₁₀ 50%
 e(PM10) min ≥ 50%
 (Pollen, sand and dust)

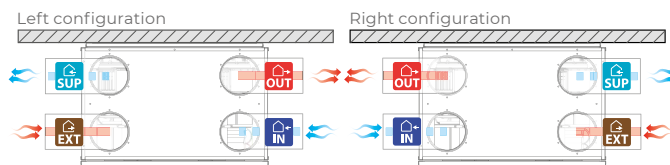
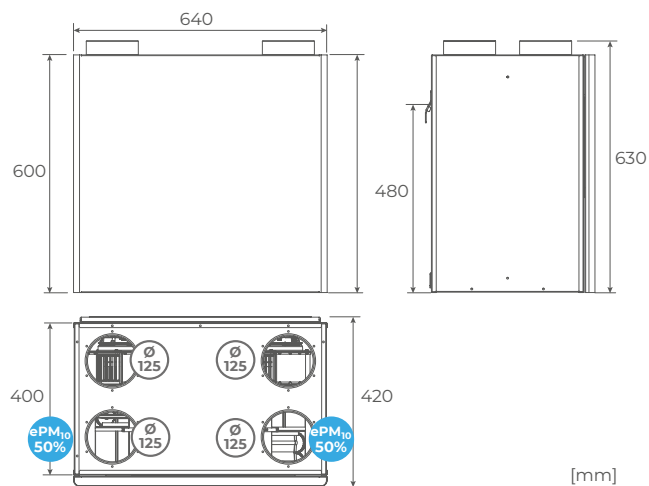



INSTALLATION

- Vertical wall-mounted
- Slope 2%

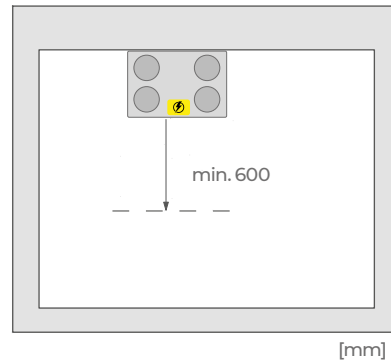
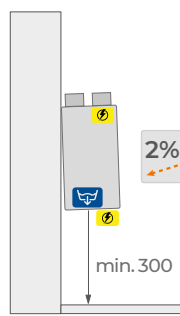

PERFORMANCE

Air flow m ³ /h	Pressure Pa	Electric cons. W
80	250	50
95	225	57
120	220	68
150	150	67

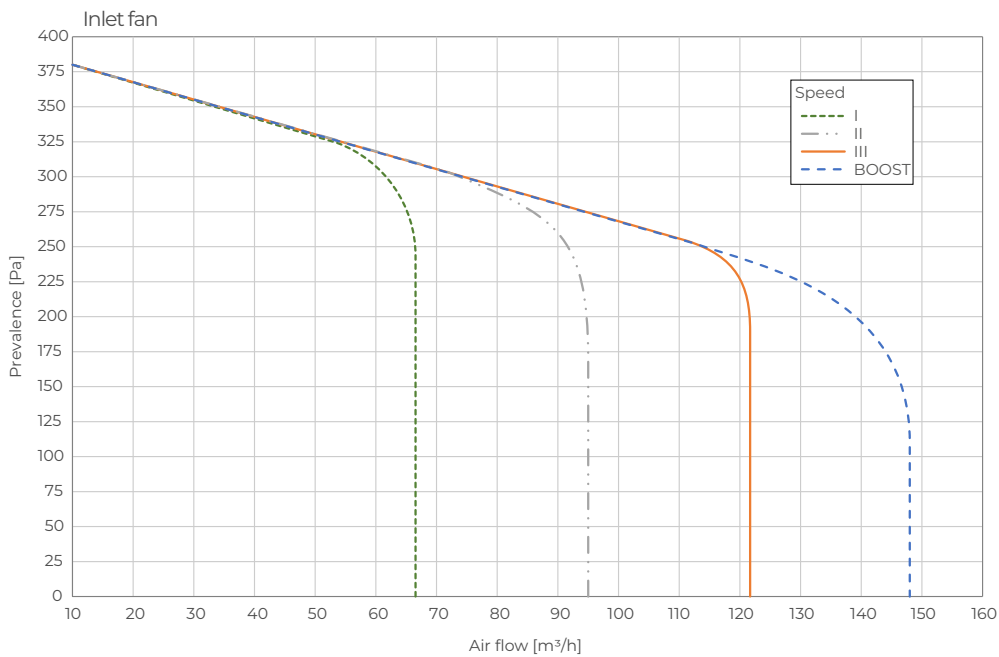

COMPLEMENTS

	Control			Siphons		Preheating		Post treatment
Name	CORE AIR SPEED	CORE AIR CONTROL	KNX-UTA Interface	SF-M 13 Condensate drain kit	SF-P N Sifowall	RE-S 05-125 Electrical resistance on/off	RE-M 05-125 Electrical resistance 0-10V	BA-P 6/10 Water exchanger
Page	102	103	106	110	110	113	115	120

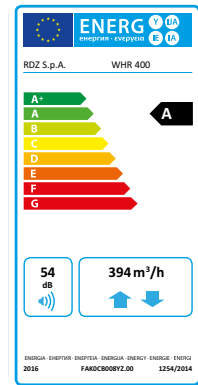

MODEL	CODE
WHR 400 (3E)	7045618
WHR 400 (EB)	7045619

Vertical wall-mounted mechanical ventilation unit with high efficiency polystyrene heat exchanger (~90%). Made with prepainted steel plate frame and internal thermo-acoustic insulation in rock wool, it is equipped with constant flow rate EC motors, F7 filters (ISO ePM1 70%) on the supply and exhaust lines, by-pass for free-cooling, and NTC sensors. Antifreeze function and dirty filter detection included. It can be managed using a dedicated control panel with simple display (WHR 400 3E), or a white LCD (WHR 400 EB). The unit can be combined with the DWF 400 dehumidification module and controlled through RDZ Wi controller.

FEATURES

- Nominal air flow rate: 394 m³/h with 100 Pa
- Sound pressure level at 1.5 m 42 dB(A)
- ePM1 70% (F7) Filter with low pressure drop, for both air extraction and supply
- Rockwool thermo acoustic insulation

TECHNICAL DATA

- Size l x h x d: 900x900x410 mm
- 4 NTC sensors
- Max. electrical power: 176 W
- Elect. power supply: 230 Vac - 50/60 Hz

CONNECTIONS AND FILTERS

- Air duct connections Ø 160 mm
- Condensate drain Ø 20 mm



ISO ePM₁
e(PM₁) min ≥ 50%
 (Virus, nanoparticles, gas)

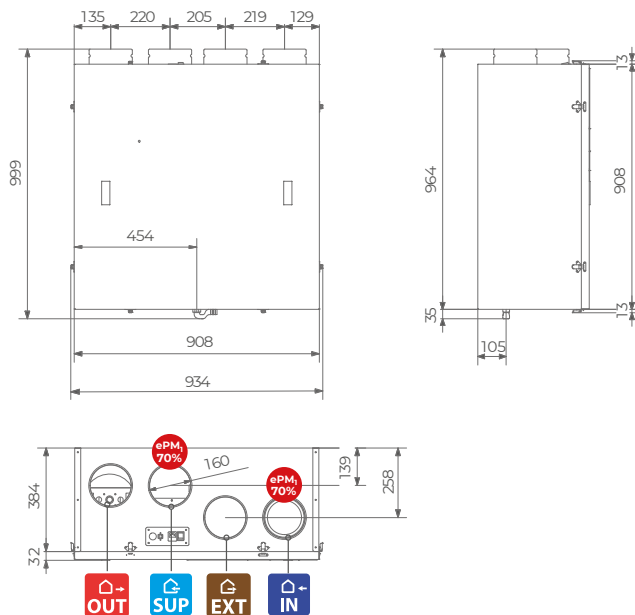



INSTALLATION

- Vertical wall-mounted



Unit weight

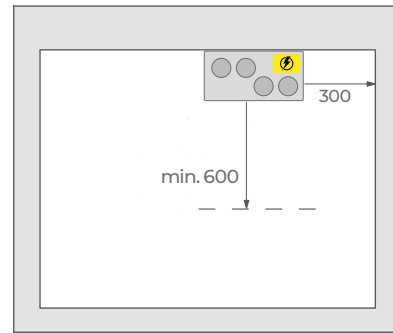
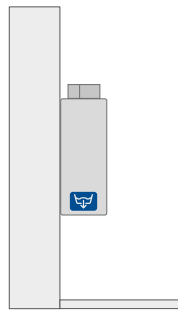

[mm]



PERFORMANCE

Air flow m ³ /h	Pressure Pa	Electric cons. W
60	100	55
230	100	75
400	100	180

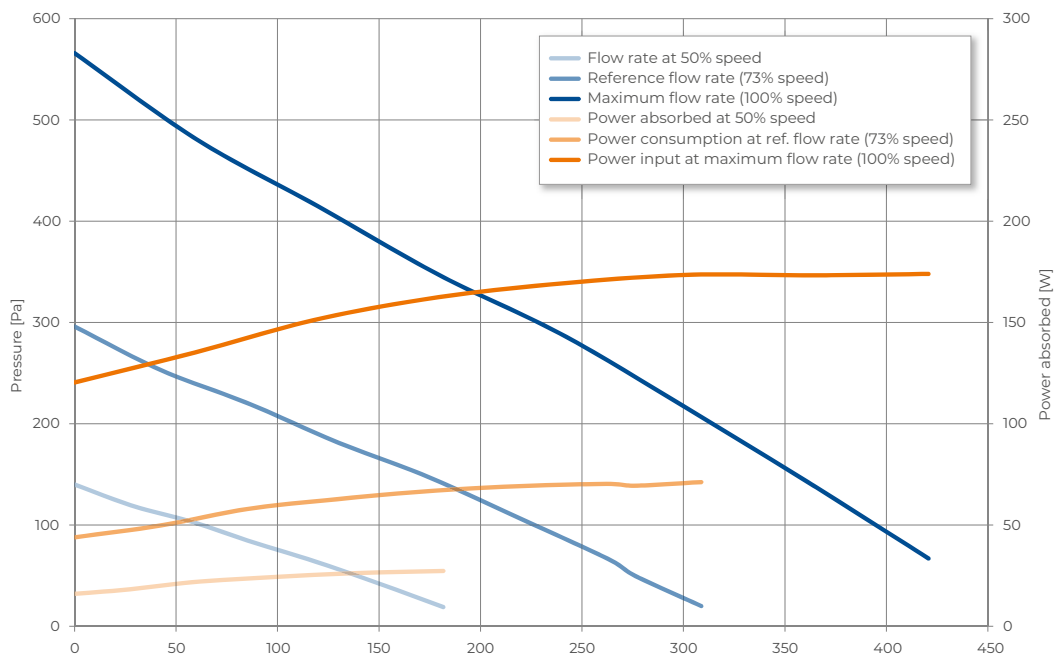

COMPLEMENTS

	Control			Siphons	Preheating		Post treatment
Name	Easy 3E Control panel	Smart EB Control panel	Core Air Conv	SF-M 15 Condensate drain kit	RE-S 10-160 Electrical resistance STD	RE-M 10-160 Electrical resistance 0-10	BA-P 6 / 10 Water exchanger
Page	107	107	104	110	113	115	120

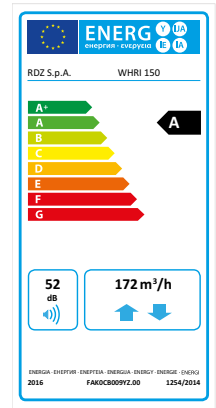

MODEL	CODE
WHRI 150 (3E)	7045525
WHRI 150 (EB)	7045526

Recessed vertical wall-mounted mechanical ventilation unit consisting of a galvanized steel plate embedded box with holes for electrical and air connections, fan unit, and front panel in galvanized steel plate painted RAL 9010. The fan unit is made up of a pre-painted steel plate frame and internal thermo-acoustic insulation in rock wool. WHRI 150 is equipped with high efficiency polypropylene heat exchanger (~90%), constant flow rate EC motors, F7 filters (ISO ePM1 70%) on the supply and exhaust lines, by-pass for free-cooling and NTC sensors. Antifreeze function and dirty filter detection included. The unit can be managed using a dedicated control panel with simple display (WHRI 150 3E ventilation unit), or a white LCD (WHRI 150 EB ventilation unit). For vertical wall installation is mandatory to use SF-M condensate drain kit.

FEATURES

- Boost air flow rate: 172 m³/h con 100 Pa
- Constant flow rate EC motors
- Rockwool thermo acoustic insulation

TECHNICAL DATA

- Size l x h x d: 520x1000x207 mm
- 4 NTC sensors
- Max. electrical power: 100 W
- Elect. power supply: 230 Vac - 50/60 Hz
- Sound pressure level at 1.5 m: 41 dB(A)

CONNECTIONS AND FILTERS

- Air duct connections Ø 125 mm
- Condensate drain Ø 12 mm



ISO ePM₁
e(PM₁) min ≥ 50%
 (Virus, nanoparticles, gas)

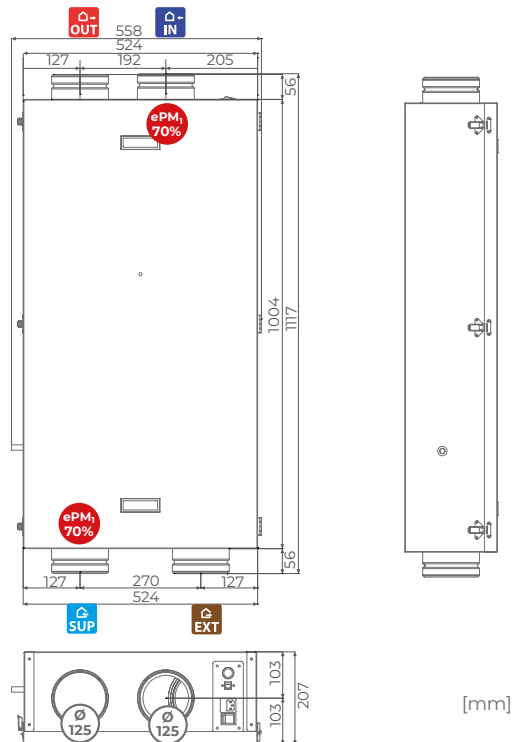



INSTALLATION

- Vertical wall-mounted (1)
- Recessed vertical wall-mounted (2)



Unit weight

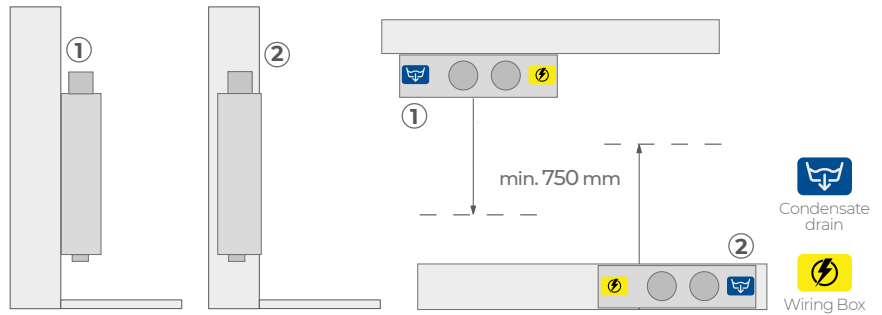

PERFORMANCE

Air flow m ³ /h	Pressure Pa	Electric cons. W
50	50	20
100	95	38
150	150	60
172	100	100

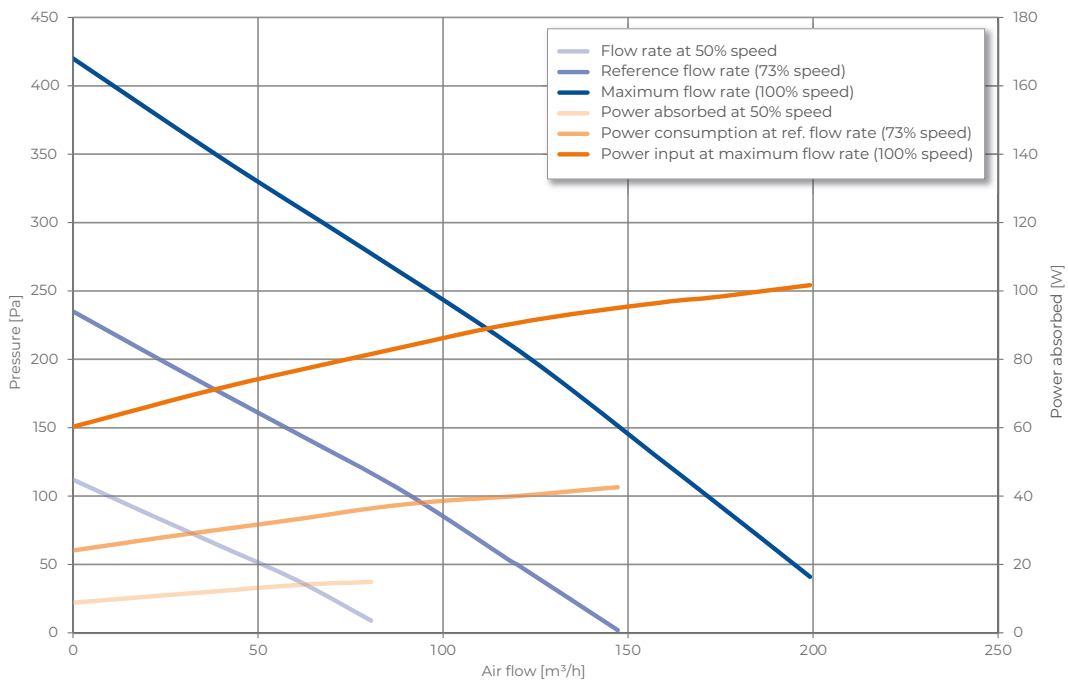

COMPLEMENTS

	Control			Siphons	Recessed accessories		
Name	Easy 3E Control panel	Smart EB Control panel	Core Air Conv	SF-M 13* Condensate drain kit	Recessed box Plus	Front panel	Adaptor for WHRI
Page	107	107	104	110	24	24	24

*Wall installation only

WHRI 150 - recessed box



WHRI 150 - front panel

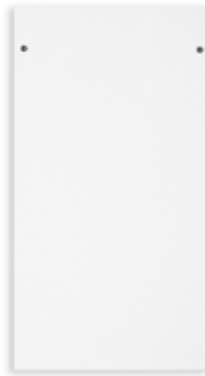

WHRI - adaptor



MODEL	CODE
Recessed box	7045542

MODEL	CODE
Front panel	7045537

SIZE	CODE
Ø 75	7045548
Ø 90	7045549

Recessed box dimensions

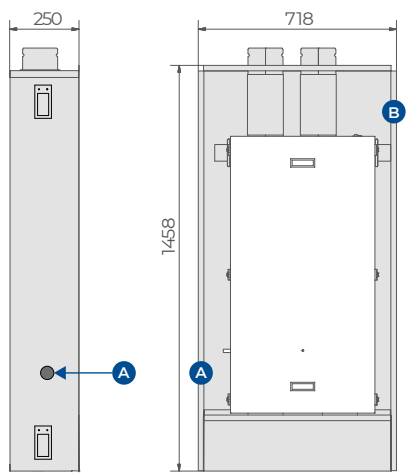

Front panel dimensions

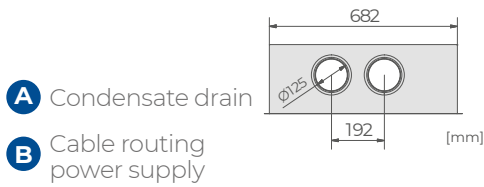
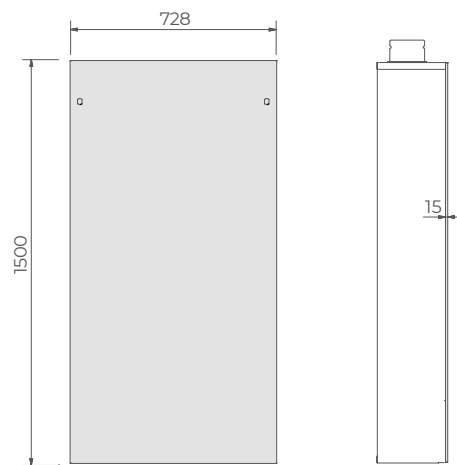

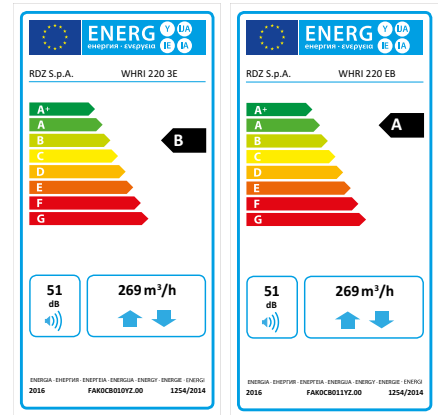

MODEL	CODE
WHRI 220 (3E)	7045530
WHRI 220 (EB)	7045531

Recessed vertical wall-mounted mechanical ventilation unit consisting of a galvanized steel plate embedded box with holes for electrical and air connections, fan unit, and front panel in galvanized steel plate painted RAL 9010. The fan unit is made up of a pre-painted steel plate frame and internal thermo-acoustic insulation in rock wool. WHRI 220 is equipped with high efficiency polypropylene heat exchanger (~90%), constant flow rate EC motors, F7 filters (ISO ePM1 70%) on the supply and exhaust lines, by-pass for free-cooling and NTC sensors. Antifreeze function and dirty filter detection included. The unit can be managed using a dedicated control panel with simple display (WHRI 220 3E ventilation unit), or a white LCD (WHRI 220 EB ventilation unit). For vertical wall installation is mandatory to use SF-M condensate drain kit.

FEATURES

- Boost air flow rate: 269 m³/h with 100 Pa
- Nominal air flow rate: 220 m³/h with 200 Pa
- Rockwool thermo acoustic insulation

TECHNICAL DATA

- Size l x h x d: 600x1000x267 mm
- 4 NTC sensors
- Max. electrical power: 173 W
- Elect. power supply 230 Vac - 50/60 Hz
- Sound pressure level at 1.5 m: 39 dB(A)

CONNECTIONS AND FILTERS

- Air duct connections Ø 160 mm
- Condensate drain Ø 12 mm

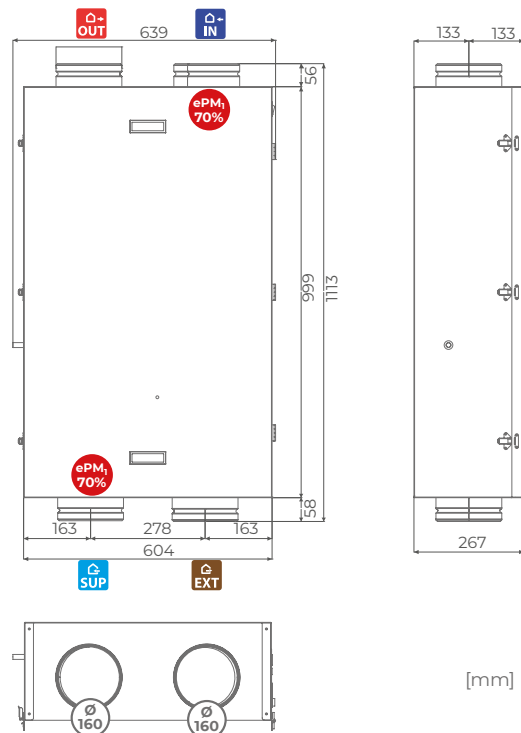
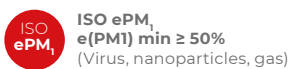



INSTALLATION

- Vertical wall-mounted (1)
- Recessed vertical wall-mounted (2)

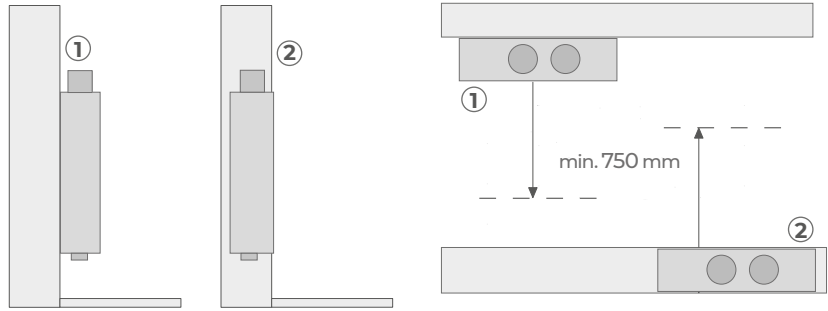

PERFORMANCE

Air flow m ³ /h	Pressure Pa	Electric cons. W
40	100	20
150	100	65
172	100	173

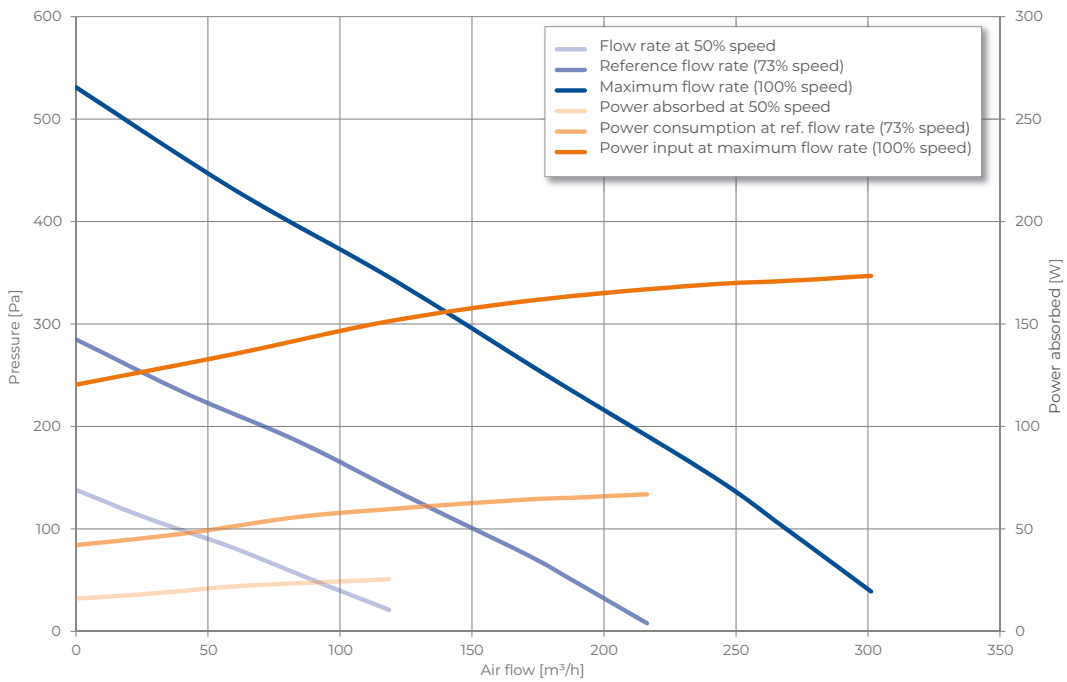

COMPLEMENTS

	Control			Siphons	Recessed accessories		
Name	Easy 3E Control panel	Smart EB Control panel	Core Air Conv	SF-M 13* Condensate drain kit	Recessed box Plus	Front panel	Adaptor for WHRI
Page	107	107	104	110	27	27	27

*Wall installation only

WHRI 220 - recessed box



WHRI 220 - front panel

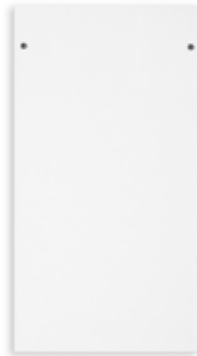

WHRI - adaptor



MODEL	CODE
Recessed box	7045547

MODEL	CODE
Front panel	7045538

SIZE	CODE
Ø 75	7045548
Ø 90	7045549

Recessed box dimensions

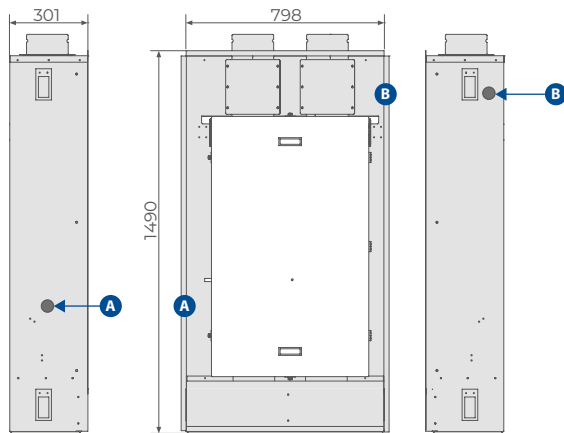

Front panel dimensions

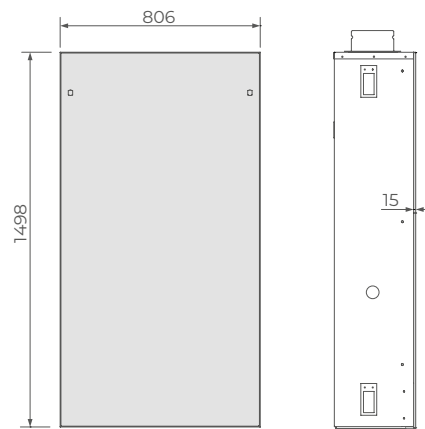

- A** Condensate drain
- B** Cable routing power supply

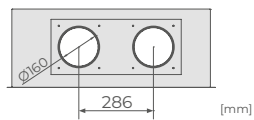

Selection guide

Mechanical ventilation with heat recovery

The residential ventilation standard (EN 16798) differing in the fresh air flow rate calculated on each occupant.

category	comfort category	fresh air flow rate in l/sec per person	fresh air flow rate in m ³ /h per person
I	Excellent	10	36 approx.
II	Good	7	25 approx.
II	Adequate	4	15 approx.

For each MVHR unit, the 50% of the whole room volume is assumed as air exchange rate. The occupancy level substained by each machine depends on the desired comfort level.

MVHR selection chart

max occupants	Comfort quality index depending on air exchange (EN 16798)					
	I excellent		II Good		III Adequate	
	ceiling	floor - wall	ceiling	floor - wall	ceiling	floor - wall
4	REFLAIR 150	WHRI 150	REFLAIR 150	WHRI 150 WHR 150 REFLAIR 150	REFLAIR 150	WHRI 150 WHR 150 REFLAIR 150
5	REFLAIR 250	WHRI 220				
6	CHR 400		REFLAIR 250	WHRI 220 REFLAIR 250		
7						
8		CHR 400	CHR 400	REFLAIR 250		
9					CHR 400	CHR 400
10	CHR 400	CHR 400	REFLAIR 250			
11				CHR 400	CHR 400	REFLAIR 250
12	CHR 400	CHR 400	REFLAIR 250			
13				CHR 400	CHR 400	REFLAIR 250
14	CHR 400	CHR 400	REFLAIR 250			
15				CHR 400	CHR 400	REFLAIR 250
16	CHR 400	CHR 400	REFLAIR 250			
17				CHR 400	CHR 400	REFLAIR 250
18	CHR 400	CHR 400	REFLAIR 250			
19				CHR 400	CHR 400	REFLAIR 250
20	CHR 400	CHR 400	REFLAIR 250			
21				CHR 400	CHR 400	REFLAIR 250
22	CHR 400	CHR 400	REFLAIR 250			
23				CHR 400	CHR 400	REFLAIR 250
24	CHR 400	CHR 400	REFLAIR 250			
25				CHR 400	CHR 400	REFLAIR 250
26	CHR 400	CHR 400	REFLAIR 250			

MVHR comparison table

type	RDZ model	nominal ventilation flow rate	available pressure with flow rate	sizing according to EN 16798			sizing 0.5 vol/h	
				max. number of people per comfort level			max. room volumes	room surface areas
		m ³ /h	Pa	I excellent	II Good	III Adequate	m ³	m ²
decentralized								
push-pull	WHR 62 PLUS*	60		2	3	4	120	~ 44
centralized								
ceiling	REFLAIR 150	105	200	4	6	10	300	~ 80
	REFLAIR 250	200	200	5	8	13	400	~ 110
	CHR 400	400	200	11	16	26	800	~ 260
floor	WHR 150 REFLAIR 150	105	200	4	6	10	300	~ 80
	REFLAIR 250	200	200	5	8	13	400	~ 110
	WHR 400	390	100	10	15	26	780	~ 260
wall recessed	WHRI 150	170	100	4	6	11	340	~ 80
	WHRI 220	270	100	7	10	17	540	~ 110

** values calculated for combined operation of two units.



Reliable, efficient, and versatile mechanical ventilation unit with heat recovery for commercial application. The machine is available in ten configurations including: countercurrent exchanger made of aluminium with efficiency higher than 90%, EC centrifugal fans, filter pressure switch (only with Smart EB electronics), F7 filters (ISO ePM1 70%) on the supply line and M5 (ISO ePM10 50%) on the extract line, and by-pass for free-cooling. Depending on the desired configuration, the following components may be also included: Easy or Smart control panel, canopy and IP55 switchboard, QA air quality sensor and ModBus.

SUMMARY FEATURES

Model	Air flow	Pressure	Elect. power supply	Air duct connections	Page
HR 90 500	570 m ³ /h	605 Pa	230 V 1F 50-60 Hz	Ø 200	32
HR 90 800	950 m ³ /h	610 Pa		Ø 250	33
HR 90 1000	1250 m ³ /h	500 Pa		Ø 315	34
HR 90 1200	1740 m ³ /h	1480 Pa		Ø 315	35
HR 90 1600	1860 m ³ /h	1480 Pa		Ø 315	36
HR 90 2200	2700 m ³ /h	1480 Pa		Ø 355	37
HR 90 3000	3500 m ³ /h	1300 Pa	400 V 3F 50-60 Hz	Ø 400	38
HR 90 4000	4400 m ³ /h	900 Pa		Ø 400	39
HR 90 5000	5300 m ³ /h	900 Pa		Ø 450	40
HR 90 8000	8500 m ³ /h	1300 Pa		810x510	41



MECHANICAL VENTILATION

Configurations and connections

The HR 90 series units are intended for horizontal installation on the ceiling and/or floor.

Horizontal ceiling - View from below

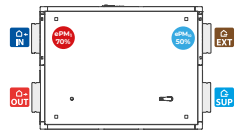
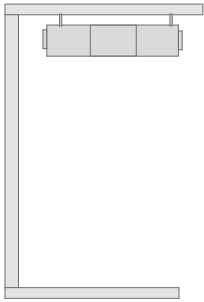

H1 (Standard)

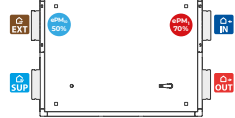

H5
Ask for quotation and code

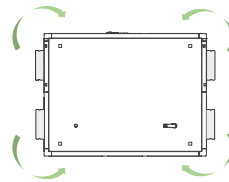

Post-delivery alternatives

Horizontal floor - Top view

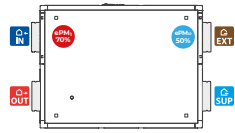
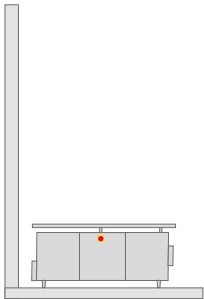

B1 (Standard)

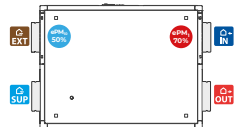

B5
Ask for quotation and code

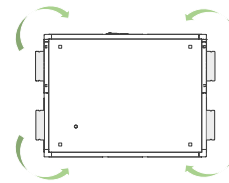

Post-delivery alternatives

Vertical floor standing - Side view

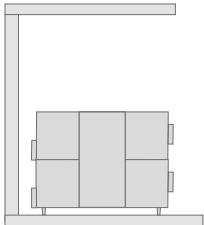

V1 (Standard)

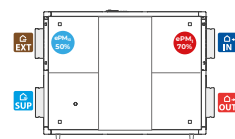

V5
Ask for quotation and code

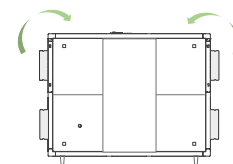

Post-delivery alternatives
*Only for units installed indoors

COMPLEMENTS

	Control			Preheating		Post treatment
Name	Easy 3E Control panel	Smart EB Control panel	Core Air Conv	RE-S Electrical resistance on/off	RE-M 0-10 electrical duct heater	BA-C Water battery
Page	107	107	104	113	115	117



Name	Code	Installation
HR 90 500 H1 3E	701HR05H13E0000	horizontal to ceiling
HR 90 500 H1 EB	701HR05H1EB0002	
HR 90 500 H1 EB CO2	On request	
HR 90 500 B1 3E IP	701HR05B13E1000	horizontal on floor
HR 90 500 B1 EB IP	701HR05B1EB1002	
HR 90 500 B1 EB IP CO2	On request	
HR 90 500 V1 3E	701HR05V13E0000	vertical on floor
HR 90 500 V1 3E IP	701HR05V13E1000	
HR 90 500 V1 EB	701HR05V1EB0002	
HR 90 500 V1 EB CO2	On request	
HR 90 500 V1 EB IP	701HR05V1EB1002	
HR 90 500 V1 EB IP CO2	On request	

FEATURES

- Nominal air flow rate: 570 m³/h with 605 Pa
- Elect. power supply 230 Vac - 50/60 Hz
- Weight: 107 Kg

PERFORMANCE

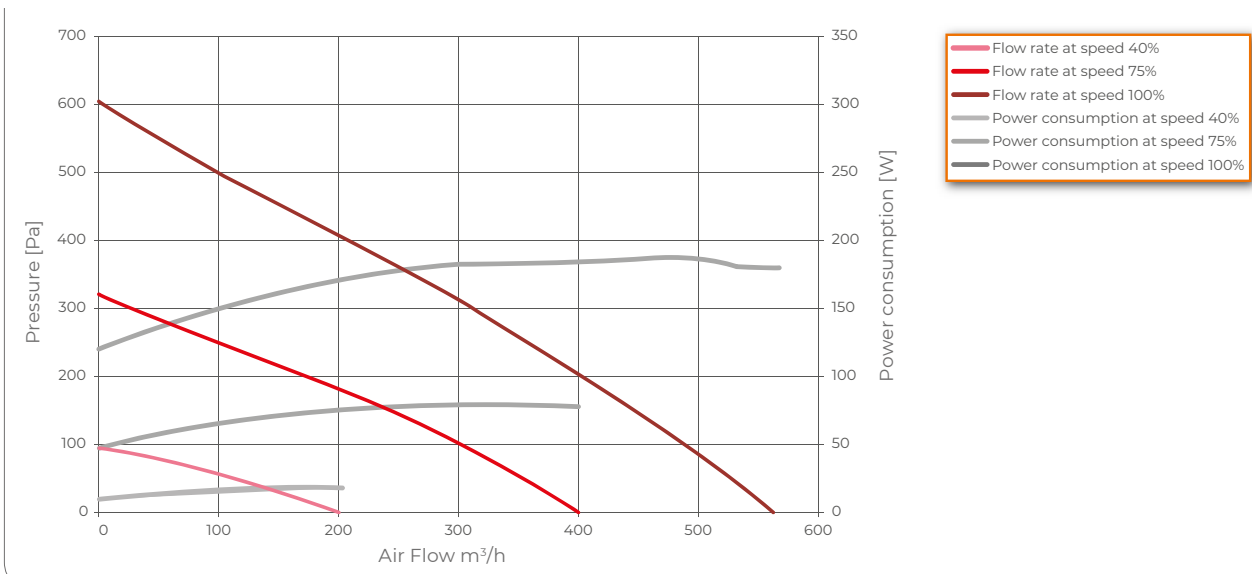

CONNECTIONS AND SIZES

- Air duct connections \varnothing 200 mm
- Condensate drain \varnothing 20 mm

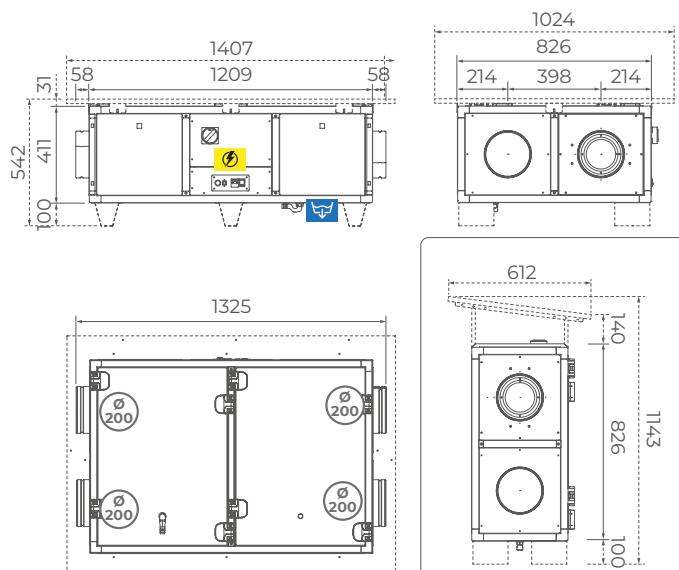



Name	Code	Installation
HR 90 800 H1 3E	701HR08H13E0000	horizontal to ceiling
HR 90 800 H1 EB	701HR08H1EB0002	
HR 90 800 H1 EB CO2	On request	
HR 90 800 B1 3E IP	701HR08B13E1000	horizontal on floor
HR 90 800 B1 EB IP	701HR08B1EB1002	
HR 90 800 B1 EB IP CO2	On request	
HR 90 800 V1 3E	701HR08V13E0000	vertical on floor
HR 90 800 V1 3E IP	701HR08V13E1000	
HR 90 800 V1 EB	701HR08V1EB0002	
HR 90 800 V1 EB CO2	On request	
HR 90 800 V1 EB IP	701HR08V1EB1002	
HR 90 800 V1 EB IP CO2	On request	

FEATURES

- Nominal air flow rate: 950 m³/h with 610 Pa
- Elect. power supply 230 Vac - 50/60 Hz
- Weight: 131 Kg

PERFORMANCE

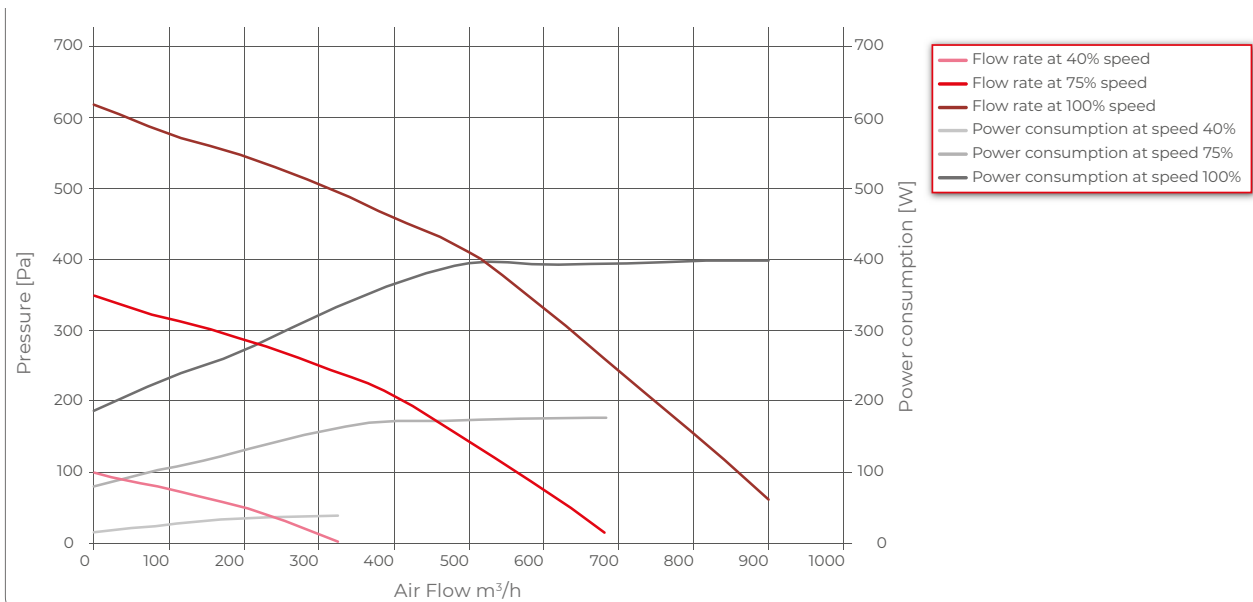

CONNECTIONS AND SIZES

- Air duct connections \varnothing 250 mm
- Condensate drain \varnothing 20 mm

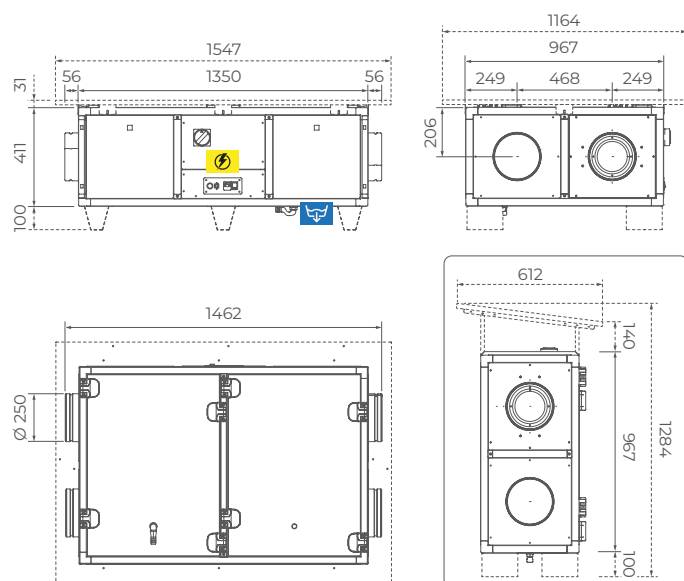



Name	Code	Installation
HR 90 1000 H1 3E	701HR10H13E0000	horizontal to ceiling
HR 90 1000 H1 EB	701HR10H1EB0002	
HR 90 1000 H1 EB CO2	On request	
HR 90 1000 B1 3E IP	701HR10B13E1000	horizontal on floor
HR 90 1000 B1 EB IP	701HR10B1EB1002	
HR 90 1000 B1 EB IP CO2	On request	
HR 90 1000 V1 3E	701HR10V13E0000	vertical on floor
HR 90 1000 V1 3E IP	701HR10V13E1000	
HR 90 1000 V1 EB	701HR10V1EB0002	
HR 90 1000 V1 EB CO2	On request	
HR 90 1000 V1 EB IP	701HR10V1EB1002	
HR 90 1000 V1 EB IP CO2	On request	

FEATURES

- Nominal air flow rate: 1250 m³/h with 500 Pa
- Elect. power supply 230 Vac - 50/60 Hz
- Weight: 186 Kg

PERFORMANCE

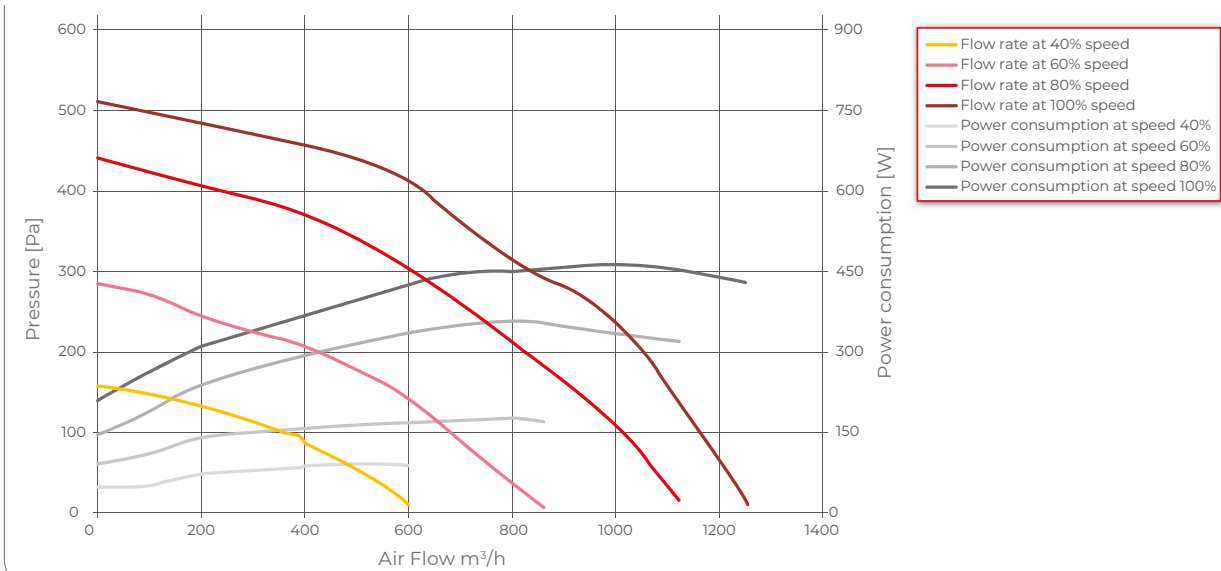

CONNECTIONS AND SIZES

- Air duct connections Ø 315 mm
- Condensate drain Ø 20 mm

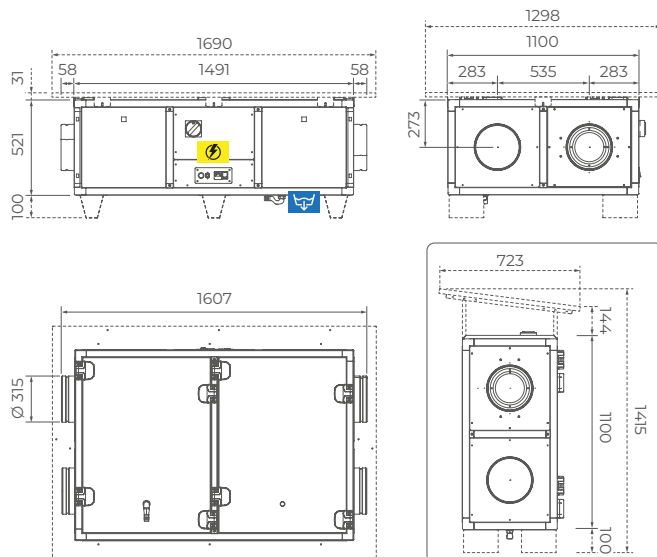



Name	Code	Installation
HR 90 1200 H1 3E	701HR12H13E0000	horizontal to ceiling
HR 90 1200 H1 EB	701HR12H1EB0002	
HR 90 1200 H1 EB CO2	On request	
HR 90 1200 B1 3E IP	701HR12B13E1000	horizontal on floor
HR 90 1200 B1 EB IP	701HR12B1EB1002	
HR 90 1200 B1 EB IP CO2	On request	
HR 90 1200 V1 3E	701HR12V13E0000	vertical on floor
HR 90 1200 V1 3E IP	701HR12V13E1000	
HR 90 1200 V1 EB	701HR12V1EB0002	
HR 90 1200 V1 EB CO2	On request	
HR 90 1200 V1 EB IP	701HR12V1EB1002	
HR 90 1200 V1 EB IP CO2	On request	

FEATURES

- Nominal air flow rate: 1740 m³/h with 1480 Pa
- Elect. power supply 230 Vac - 50/60 Hz
- Weight: 188 Kg

PERFORMANCE

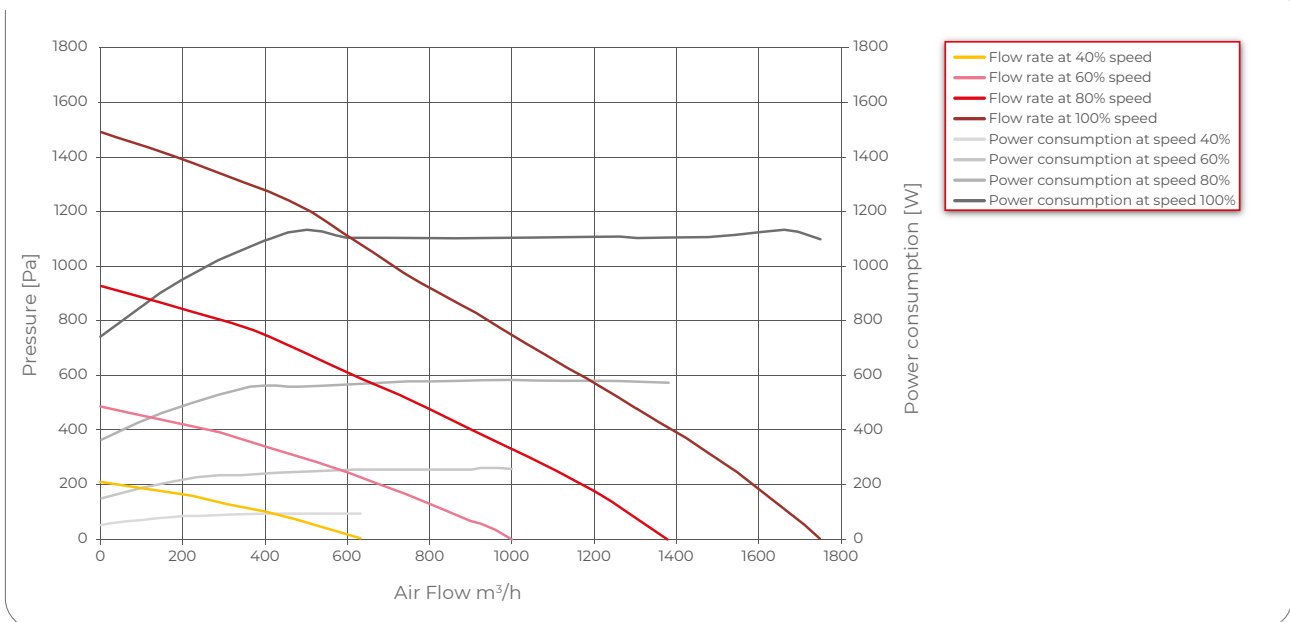

CONNECTIONS AND SIZES

- Air duct connections \varnothing 315 mm
- Condensate drain \varnothing 20 mm

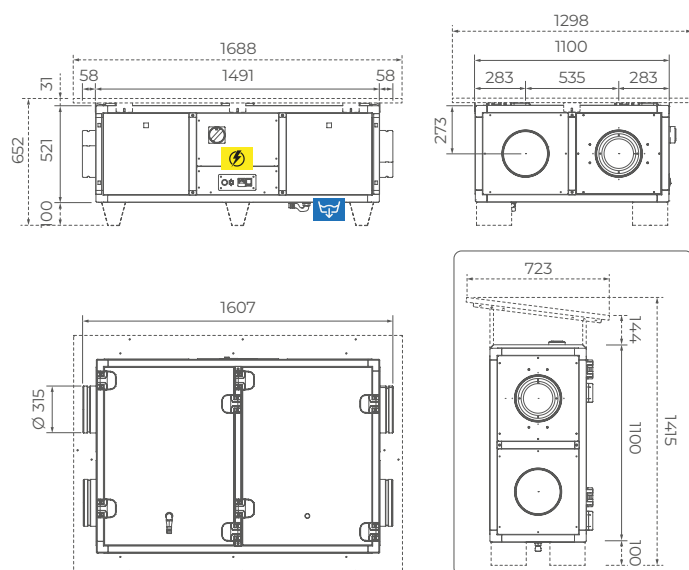



Name	Code	Installation
HR 90 1600 H1 3E	701HR16H13E0000	horizontal to ceiling
HR 90 1600 H1 EB	701HR16H1EB0002	
HR 90 1600 H1 EB CO2	On request	
HR 90 1600 B1 3E IP	701HR16B13E1000	horizontal on floor
HR 90 1600 B1 EB IP	701HR16B1EB1002	
HR 90 1600 B1 EB IP CO2	On request	
HR 90 1600 V1 3E	701HR16V13E0000	vertical on floor
HR 90 1600 V1 3E IP	701HR16V13E1000	
HR 90 1600 V1 EB	701HR16V1EB0002	
HR 90 1600 V1 EB CO2	On request	
HR 90 1600 V1 EB IP	701HR16V1EB1002	
HR 90 1600 V1 EB IP CO2	On request	

FEATURES

- Nominal air flow rate: 1860 m³/h with 1480 Pa
- Elect. power supply 230 Vac - 50/60 Hz
- Weight: 212 Kg

PERFORMANCE

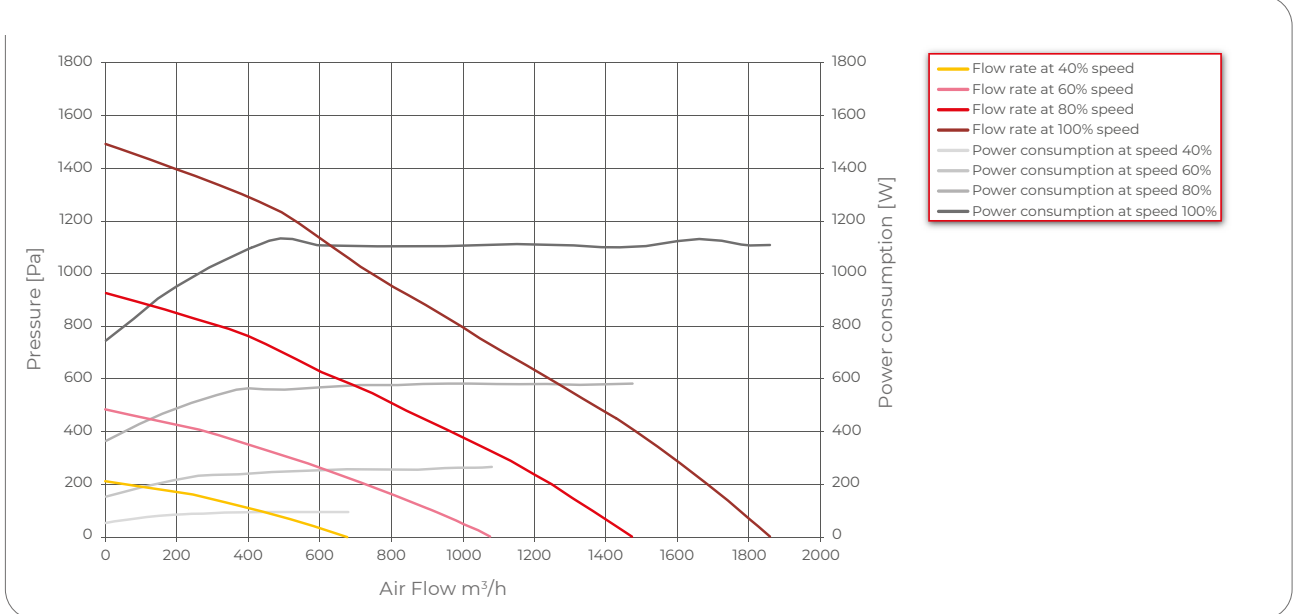

CONNECTIONS AND SIZES

- Air duct connections Ø 315 mm
- Condensate drain Ø 20 mm

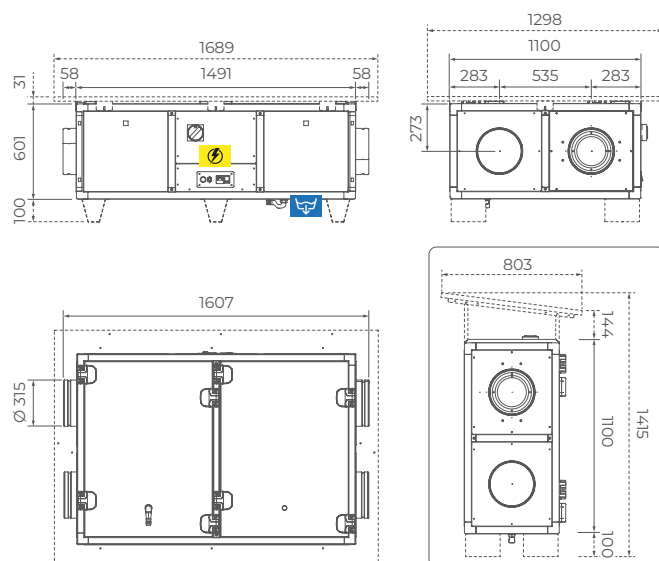



Name	Code	Installation
HR 90 2200 H1 3E	701HR22H13E0000	horizontal to ceiling
HR 90 2200 H1 EB	701HR22H1EB0002	
HR 90 2200 H1 EB CO2	On request	
HR 90 2200 B1 3E IP	701HR22B13E1000	horizontal on floor
HR 90 2200 B1 EB IP	701HR22B1EB1002	
HR 90 2200 B1 EB IP CO2	On request	
HR 90 2200 V1 3E	701HR22V13E0000	vertical on floor
HR 90 2200 V1 3E IP	701HR22V13E1000	
HR 90 2200 V1 EB	701HR22V1EB0002	
HR 90 2200 V1 EB CO2	On request	
HR 90 2200 V1 EB IP	701HR22V1EB1002	
HR 90 2200 V1 EB IP CO2	On request	

FEATURES

- Nominal air flow rate: 2700 m³/h with 1300 Pa
- Elect. power supply 230 Vac - 50/60 Hz
- Weight: 242 Kg

PERFORMANCE

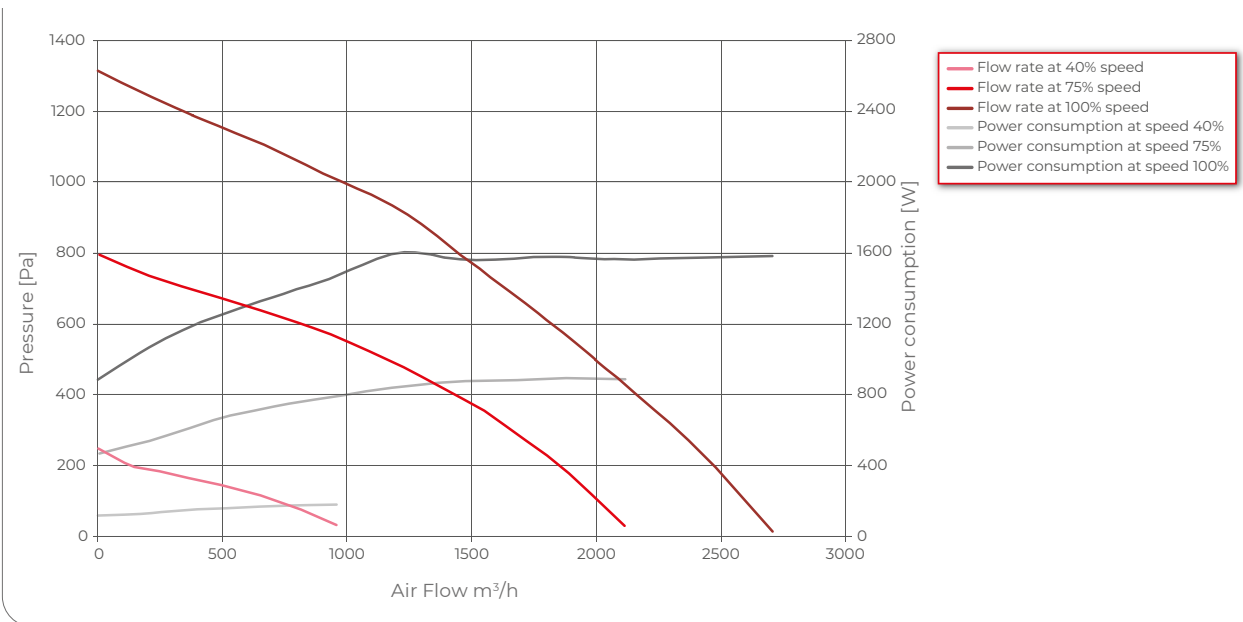

CONNECTIONS AND SIZES

- Air duct connections \varnothing 355 mm
- Condensate drain \varnothing 20 mm

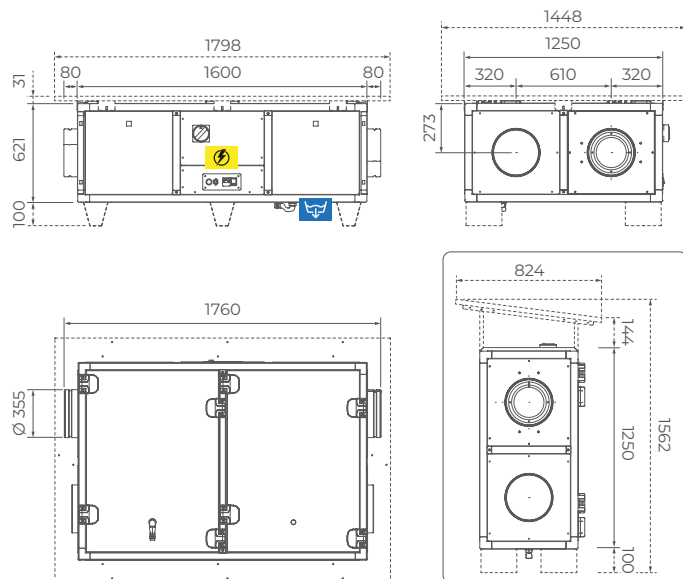



Name	Code	Installation
HR 90 3000 V1 3E	701HR30V13E0000	vertical on floor
HR 90 3000 V1 3E IP	701HR30V13E1000	
HR 90 3000 V1 EB	701HR30V1EB0002	
HR 90 3000 V1 EB CO2	On request	
HR 90 3000 V1 EB IP	701HR30V1EB1002	
HR 90 3000 V1 EB IP CO2	On request	

FEATURES

- Nominal air flow rate: 3500 m³/h head up to 1250 Pa
- Elect. power supply 400 Vac - 50/60 Hz
- Weight: 304 Kg

PERFORMANCE

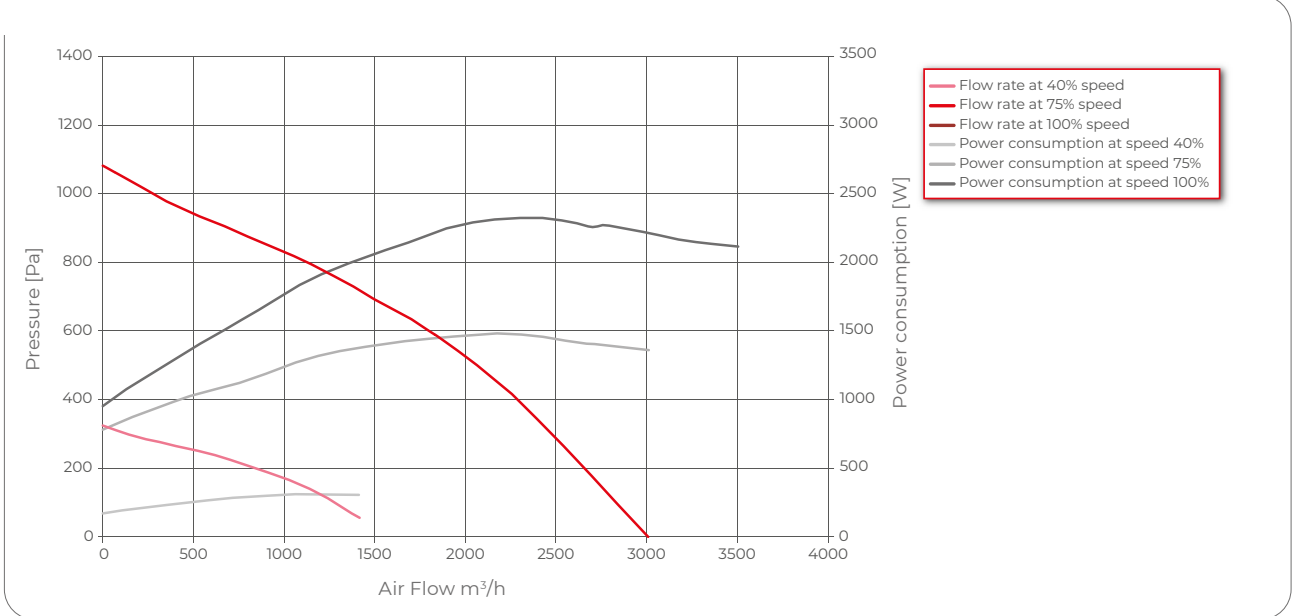

CONNECTIONS AND SIZES

- Air duct connections Ø 400 mm
- Condensate drain Ø 20 mm

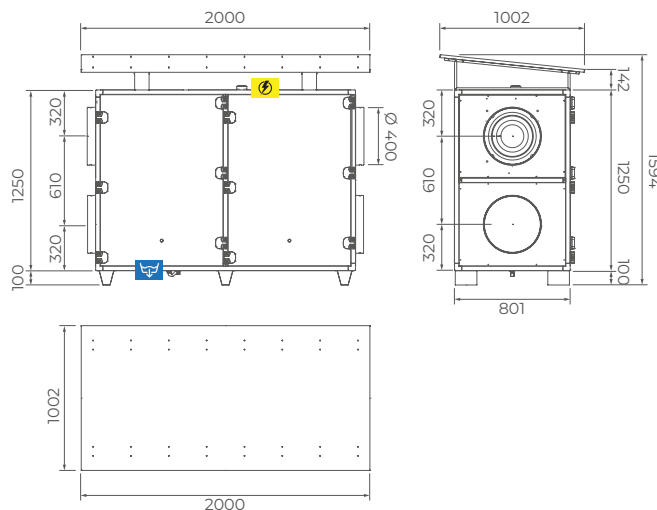



Name	Code	Installation
HR 90 4000 V1 3E	701HR40V13E0000	vertical on floor
HR 90 4000 V1 3E IP	701HR40V13E1000	
HR 90 4000 V1 EB	701HR40V1EB0002	
HR 90 4000 V1 EB CO2	On request	
HR 90 4000 V1 EB IP	701HR40V1EB1002	
HR 90 4000 V1 EB IP CO2	On request	

FEATURES

- Nominal air flow rate: 4400 m³/h head up to 900 Pa
- Elect. power supply 400 Vac - 50/60 Hz
- Weight: 381 Kg

PERFORMANCE

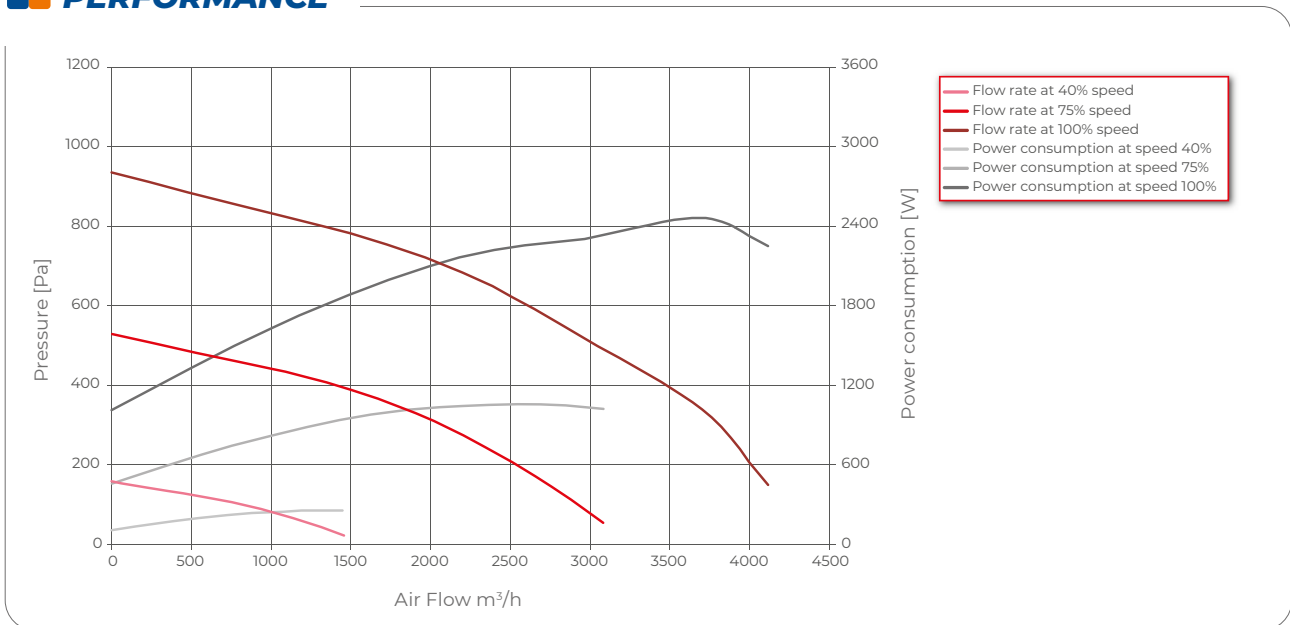

CONNECTIONS AND SIZES

- Air duct connections \varnothing 400 mm
- Condensate drain \varnothing 20 mm

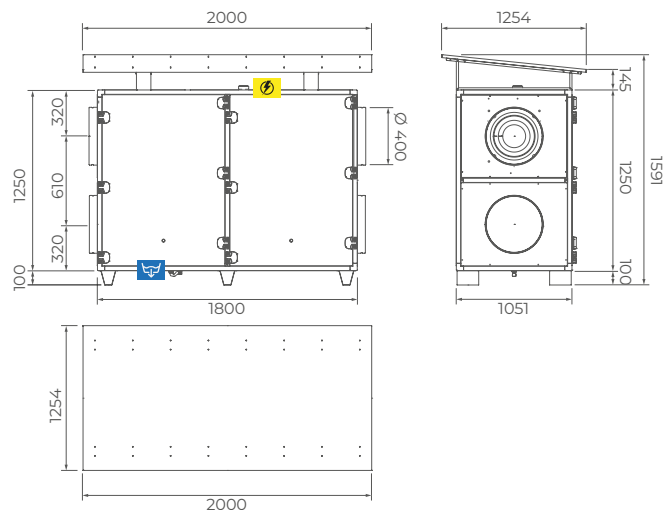



Name	Code	Installation
HR 90 5000 V1 3E	701HR50V13E0000	vertical on floor
HR 90 5000 V1 3E IP	701HR50V13E1000	
HR 90 5000 V1 EB	701HR50V1EB0002	
HR 90 5000 V1 EB CO2	On request	
HR 90 5000 V1 EB IP	701HR50V1EB1002	
HR 90 5000 V1 EB IP CO2	On request	

FEATURES

- Nominal air flow rate: 5300 m³/h head up to 900 Pa
- Elect. power supply 400 Vac - 50/60 Hz
- Weight: 455 Kg

PERFORMANCE

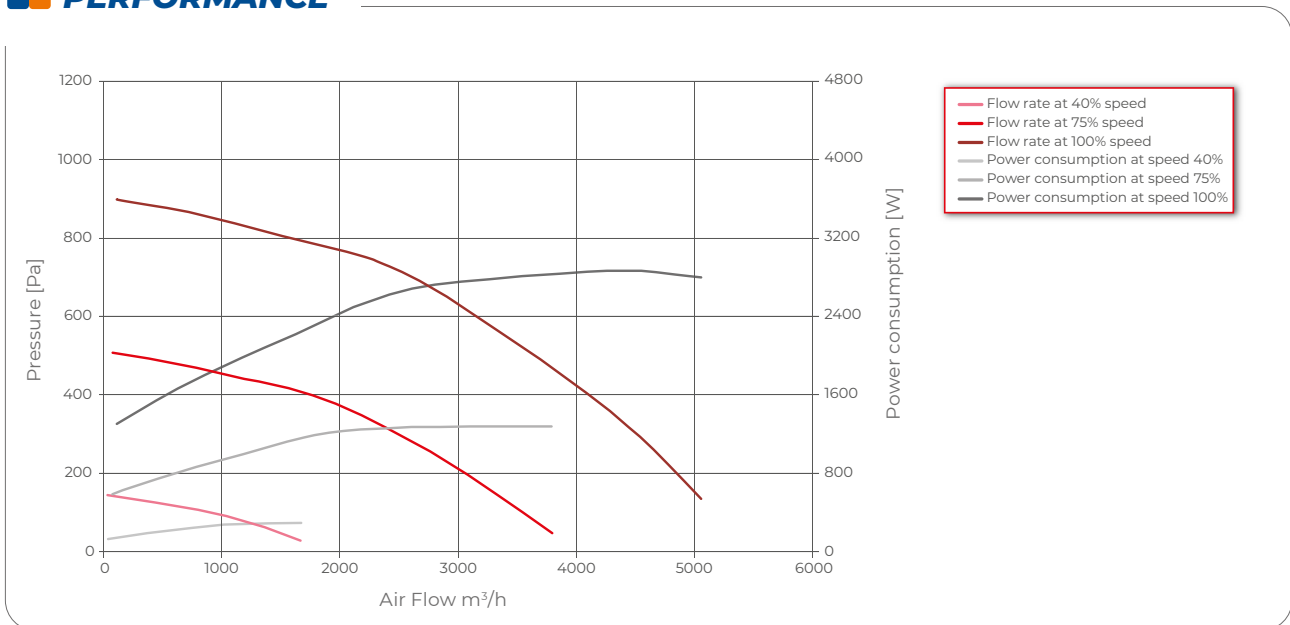

CONNECTIONS AND SIZES

- Air duct connections \varnothing 450 mm
- Condensate drain \varnothing 20 mm

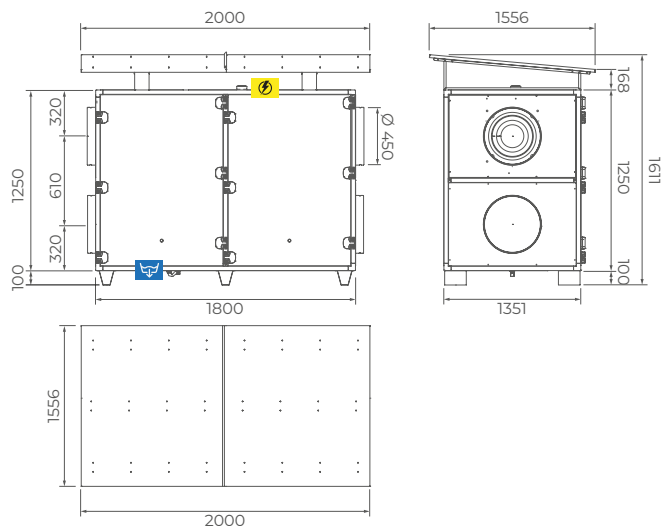

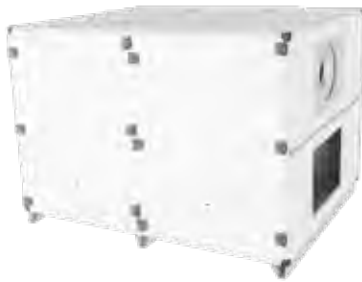

Name	Code	Installation
HR 90 8000 V1 3E	701HR80V13E0000	vertical on floor
HR 90 8000 V1 3E IP	701HR80V13E1000	
HR 90 8000 V1 EB	701HR80V1EB0002	
HR 90 8000 V1 EB CO2	On request	
HR 90 8000 V1 EB IP	701HR80V1EB1002	
HR 90 8000 V1 EB IP CO2	On request	

FEATURES

- Nominal air flow rate: 8500 m³/h head up to 1300 Pa
- Elect. power supply 400 Vac - 50/60 Hz
- Weight: 780 Kg

PERFORMANCE

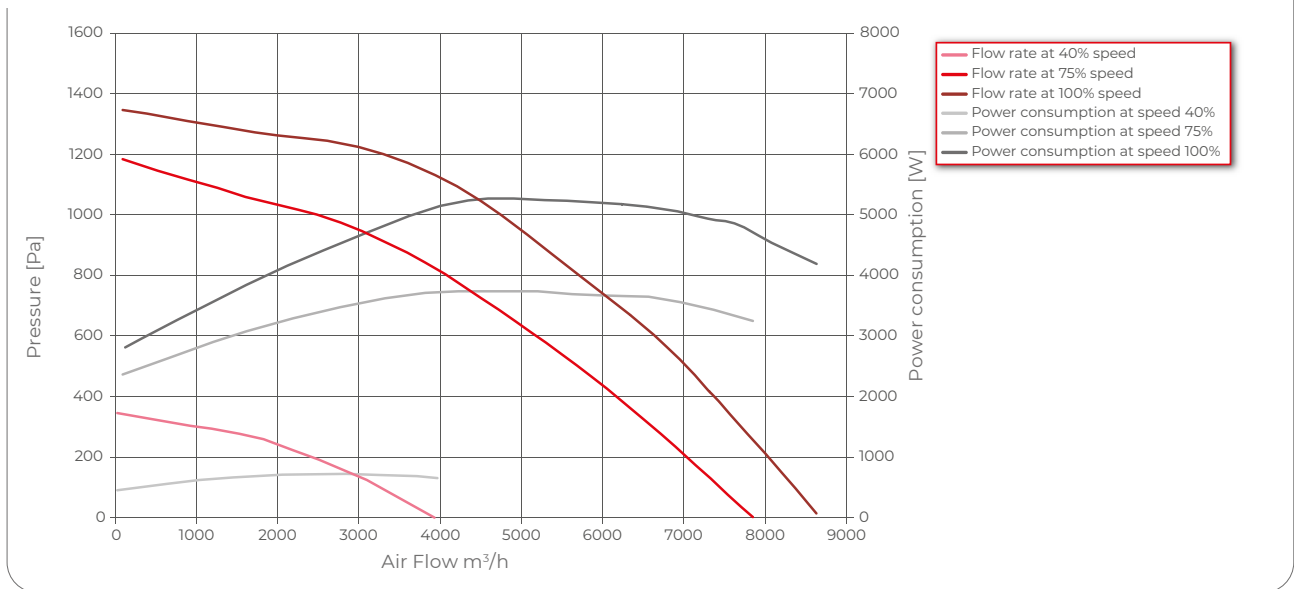

CONNECTIONS AND SIZES

- Air duct connections 810X510 mm
- Condensate drain Ø 20 mm

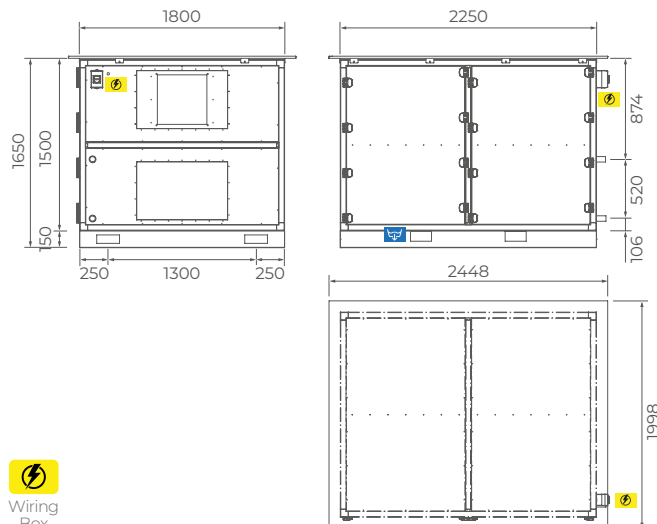

Unit selection guide

Mechanical ventilation with heat recovery

HR mechanical ventilation units with heat recovery are characterized by high flow rates and are suitable for applications with large number of people.

The wide range of available sizes allows to meet the needs of rooms and buildings occupied by up to 200 people.

In the following table we report the number of people satisfied by each unit, considering an air flow rate of 11 l/s per person, as required by the UNI 10339 standard.

	MODEL								
	HR 90 500	HR 90 800	HR 90 1200	HR 90 1600	HR 90 2200	HR 90 3000	HR 90 4000	HR 90 5000	HR 90 8000
Air flow m³/h	540	880	1300	1580	2050	2620	3450	4200	7200
N° People	13	22	32	39	51	66	87	106	181
5									
10									
15	13								
20									
25		22							
30									
35			32						
40				39					
45									
50									
55					51				
60									
65									
70						66			
75									
80									
85									
90							87		
95									
100									
105									
110								106	
115									
120									
125									
130									
135									
140									
145									
150									
155									
160									
165									
170									
175									
180									
185									181

VMC ≥ 500 m³/h

The HR UA series of mechanical ventilation units with heat recovery are machines designed to treat large volumes of air. Available in a wide range of capacities and configurations, they meet the air changeover needs in tertiary buildings of different types and sizes.

The units are constructed with self-supporting sandwich panels of 40 mm thick pre-painted sheet metal with rock wool thermo-acoustic insulation. They are equipped with a polypropylene countercurrent heat recovery unit with efficiency >90% and are fitted with EC-type centrifugal fans with backward inclined blades.

Configurations and connections

Vertical floor standing

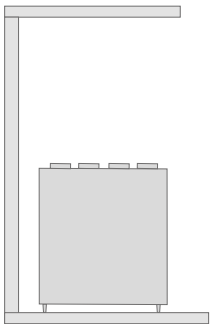

Mod. HR UA 800 - 1200 - 3000

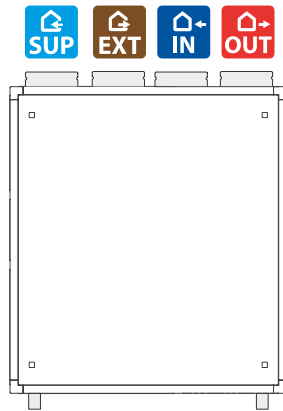

< Left >

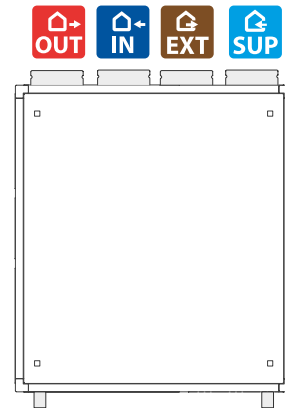

Right >

Mod. HR UA 2200

-  **SUP** Supply Air
-  **IN** Fresh Air Inlet
-  **EXT** Stale Air Extraction
-  **OUT** Exhaust Air

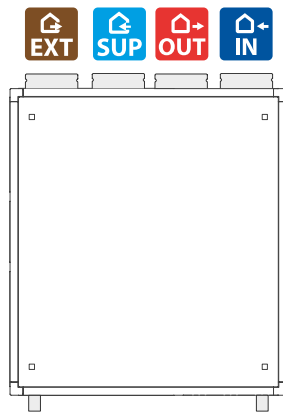

< Left >

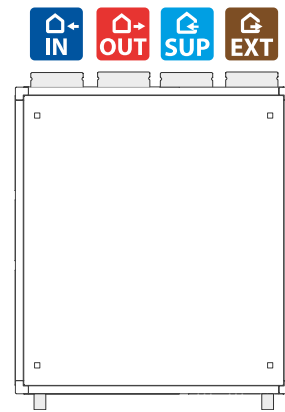

Right >



Name	Code	Installation
HR UA 800 DX 3E	702HR08D3E00000	vertical on floor
HR UA 800 DX EB	702HR08DEB02000	
HR UA 800 DX EB CO2	702HR08DEB22000	
HR UA 800 SX 3E	702HR08S3E00000	
HR UA 800 SX EB	702HR08SEB02000	
HR UA 800 SX EB CO2	702HR08SEB22000	

FEATURE

- Nominal air flow rate: 950 m³/h head up to 750 Pa
- Elect. power supply 230 Vac - 50/60 Hz
- Weight: 95 Kg

PERFORMANCE

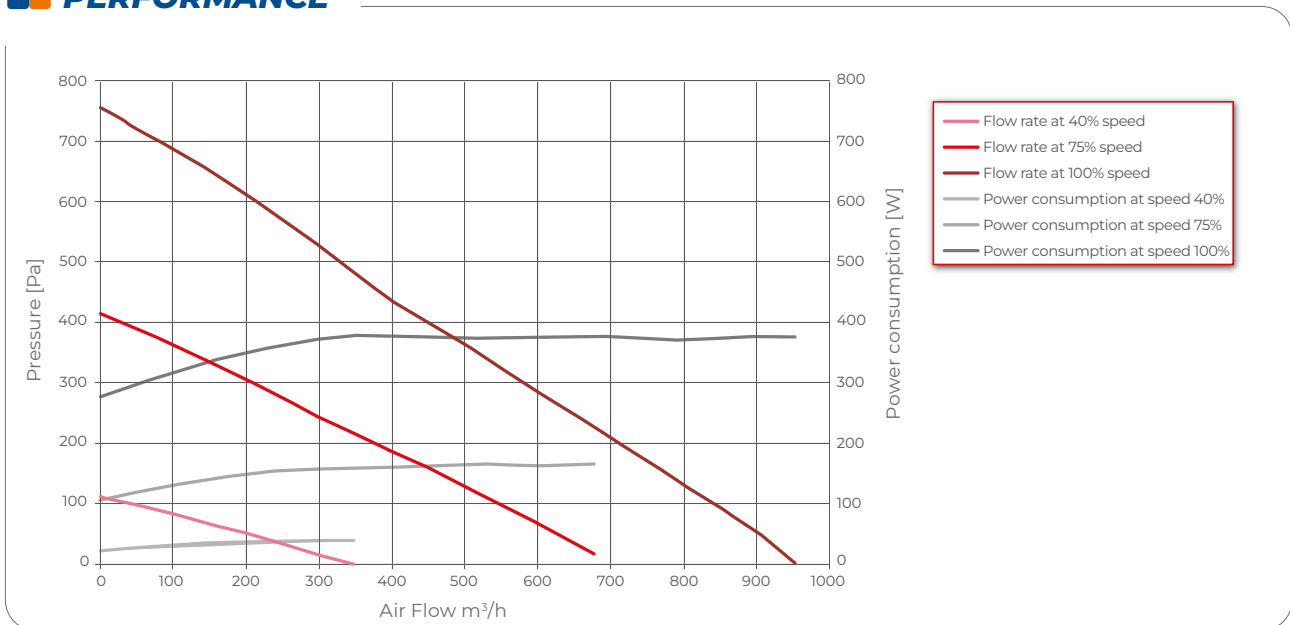

CONNECTIONS AND SIZES

- Air duct connections Ø 250 mm
- Condensate drain Ø 20 mm

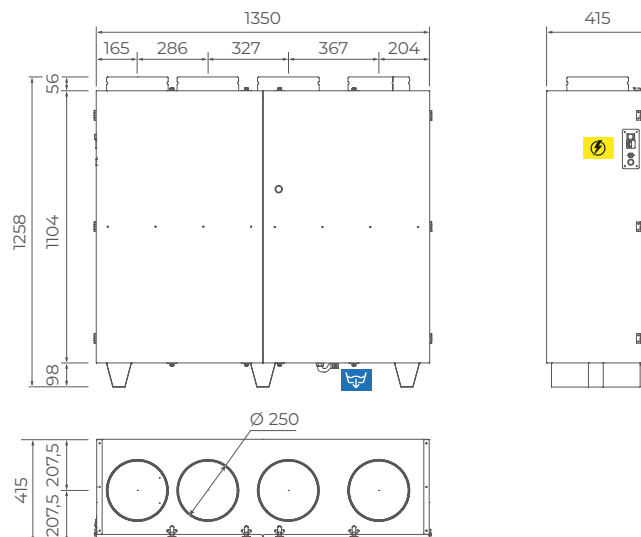



Name	Code	Installation
HR UA 1200 DX 3E	702HRI2D3E00000	vertical on floor
HR UA 1200 DX EB	702HRI2DEB02000	
HR UA 1200 DX EB CO2	702HRI2DEB22000	
HR UA 1200 SX 3E	702HRI2S3E00000	
HR UA 1200 SX EB	702HRI2SEB02000	
HR UA 1200 SX EB CO2	702HRI2SEB22000	

FEATURE

- Nominal air flow rate: 1500 m³/h head up to 1600 Pa
- Elect. power supply 230 Vac - 50/60 Hz
- Weight: 110 Kg

PERFORMANCE

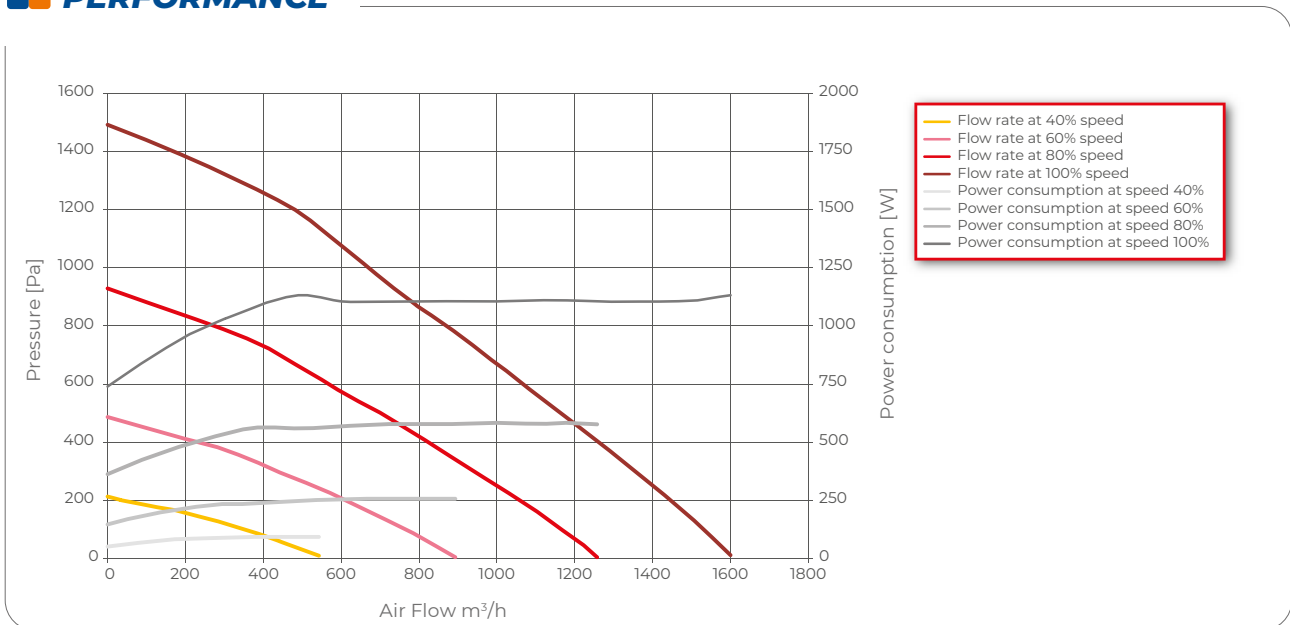

CONNECTIONS AND SIZES

- Air duct connections Ø 315 mm
- Condensate drain Ø 20 mm

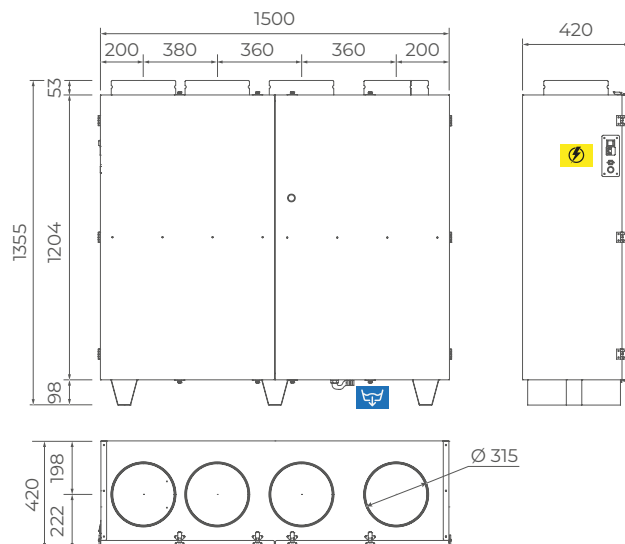



Name	Code	Installation
HR UA 2200 DX 3E	702HR22D3E00000	vertical on floor
HR UA 2200 DX EB	702HR22DEB02000	
HR UA 2200 DX EB CO2	702HR22DEB22000	
HR UA 2200 SX 3E	702HR22S3E00000	
HR UA 2200 SX EB	702HR22SEB02000	
HR UA 2200 SX EB CO2	702HR22SEB22000	

FEATURE

- Nominal air flow rate: 2500 m³/h head up to 1300 Pa
- Elect. power supply 230 Vac - 50/60 Hz
- Weight: 220 Kg

PERFORMANCE

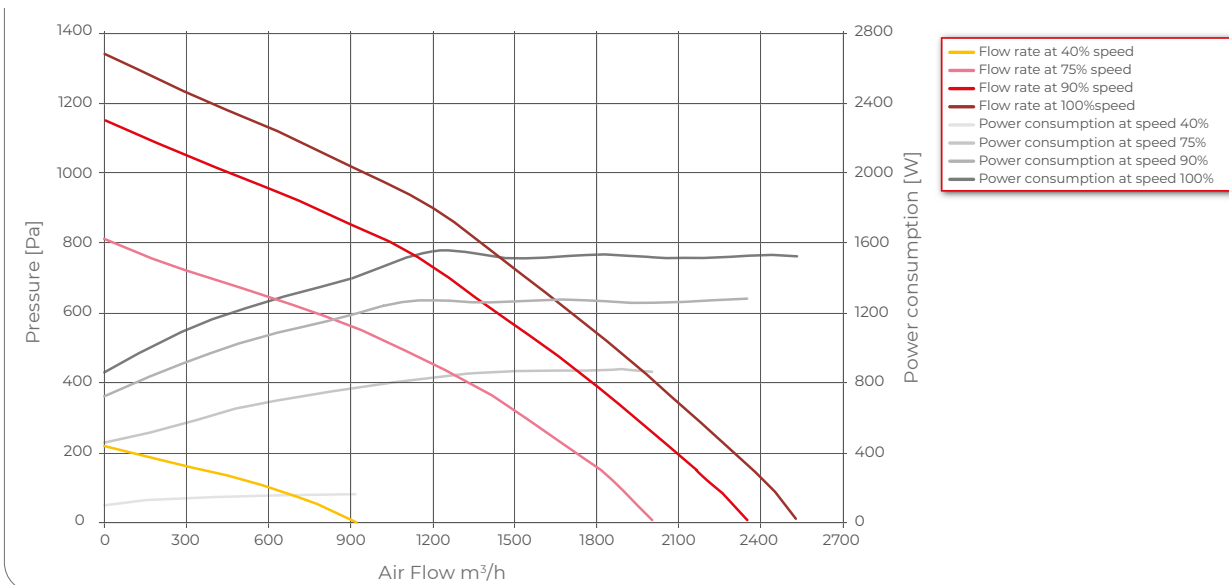

CONNECTIONS AND SIZES

- Air duct connections Ø 355 mm
- Condensate drain Ø 20 mm

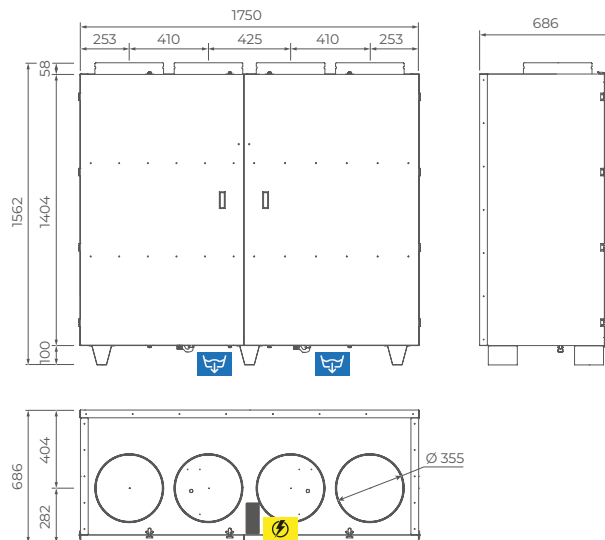



Name	Code	Installation
HR UA 3000 DX 3E	702HR30D3E00000	vertical on floor
HR UA 3000 DX EB	702HR30DEB02000	
HR UA 3000 DX EB CO2	702HR30DEB22000	
HR UA 3000 SX 3E	702HR30S3E00000	
HR UA 3000 SX EB	702HR30SEB02000	
HR UA 3000 SX EB CO2	702HR30SEB22000	

FEATURE

- Nominal air flow rate: 3500 m³/h head up to 1270 Pa
- Elect. power supply 400 Vac - 50/60 Hz
- Weight: 355 Kg

PERFORMANCE

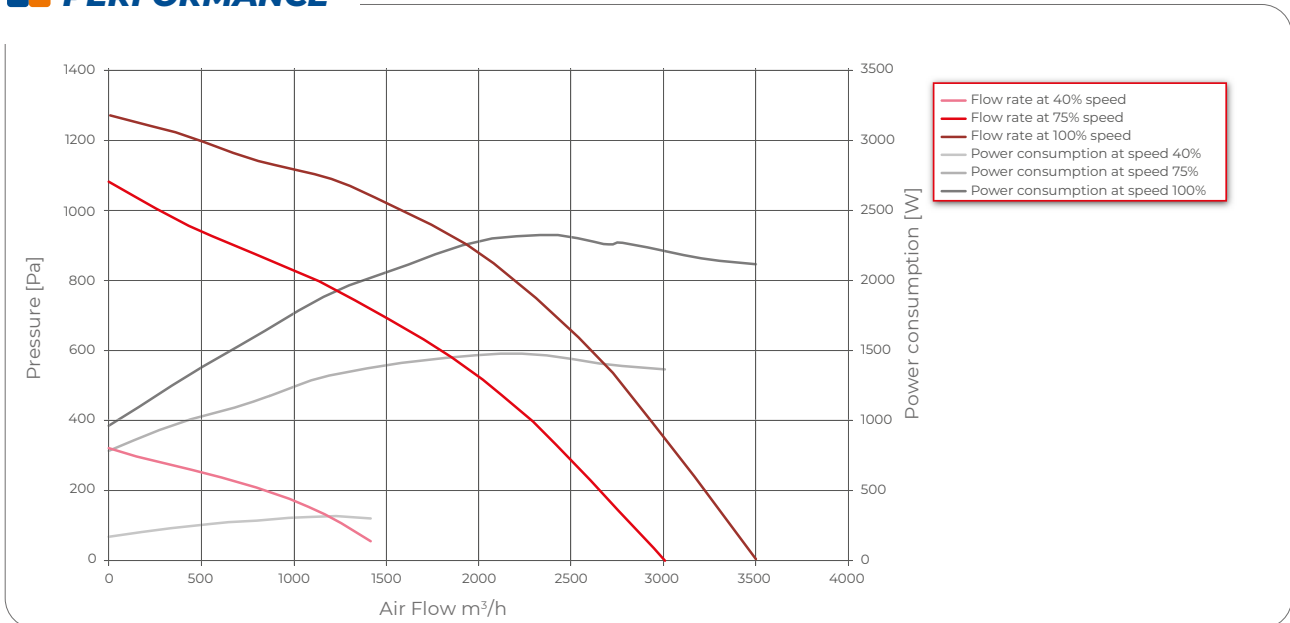

CONNECTIONS AND SIZES

- Air duct connections Ø 400 mm
- Condensate drain Ø 20 mm

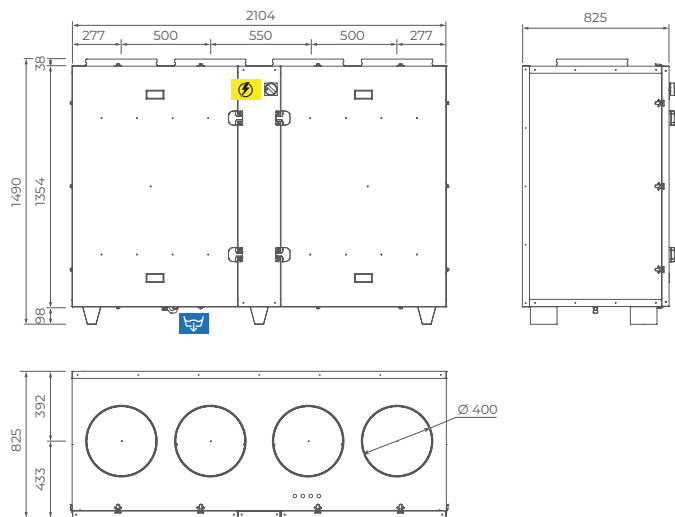

AHU for school buildings and commercial sector environments

The Indoor HR series of mechanical ventilation units are machines that do not require ducting on the room side, designed for continuous air renewal in tertiary sector environments such as schools, commercial spaces and nursing homes.

Available in 400 and 1000 m³/h versions, they are designed to be easily integrated into existing buildings. They are offered in different configurations to facilitate the connection of external air intakes (inlet and exhaust) and can be installed either on the ceiling or on the floor depending on the characteristics of the room that houses them.

The Indoor HR units consist of a minimalist self-supporting structure in white pre-painted sheet metal and are equipped with rock wool thermo-acoustic insulation, which guarantees high performance also in terms of silence.

The F7 filters (ePM1 70%), present in both the air intake and extraction ducts, are easy to replace and allow the preservation of the internal components of the machine but, above all, guarantee the entry of healthy air, free of fine dust, pollen and other pollutants.

Selection Guide

For the correct design of controlled mechanical ventilation systems in public school buildings, the CAM decree applies, which provides two options for calculating renewal rates:

1) follow the indications of UNI 10339 (where the per capita fresh air flow rates are fixed and depend on the type of school: primary, junior high, etc.) or

2) follow the indications of UNI EN 16798-1.

In the latter case, the fresh air flow rate is derived from the sum of two quantities, to take into account the pollution generated by people, a function of the number of occupants, and by the building, a function of the floor area. In particular, the CAM decree prescribes:

- For new constructions, demolitions and reconstructions, extensions and elevations, to apply Class II indoor environmental quality and to consider VLPB (Very Low Polluting Buildings).

- For major renovations on the second level, to apply Class II indoor environmental quality and to consider the LPB (Low Polluting Buildings) building.

In cases where there are obvious technical and/or economic constraints that do not allow the application of the above, only for major renovations of the second level and energy upgrades, there is a third option, which allows the application of Class III of indoor environmental quality and to consider the building LPB.

Renewal flow rates in school environments according to EN 16798-1					
Category	Capacity per person L/(s person)		Capacity per surface area L/(s m ²)		
			VLPB	LPB	NLPB
I	10	+	0.5	1.0	2.0
II	7*		0.35	0.7*	1.4
III	4		0.2	0.4	0.8
IV	2.5		0.15	0.3	0.6

VLPB: Very Low Polluting Buildings - LPB: Low Polluting Buildings - NLPB: Non Low Polluting Buildings
 *Values to be applied according to CAM decree for major renovations of second level

Configurations and connections

Horizontal ceiling

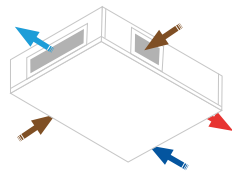
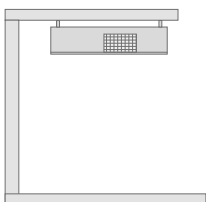

Vertical floor standing

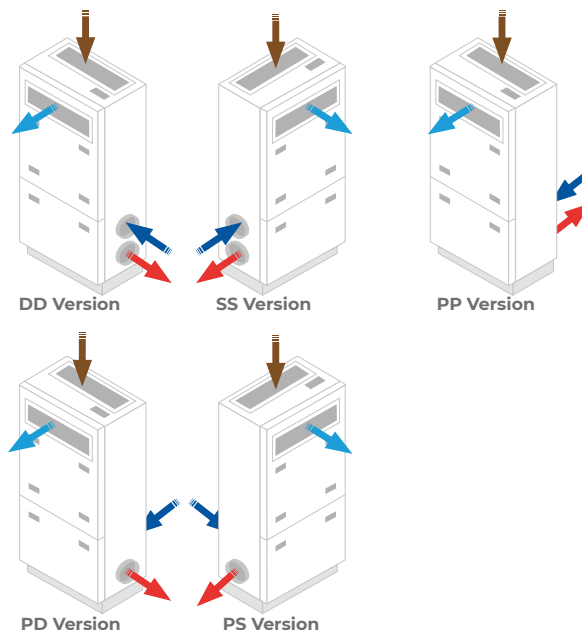
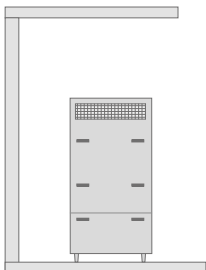

INDOOR HR 400C

FIELD OF APPLICATION

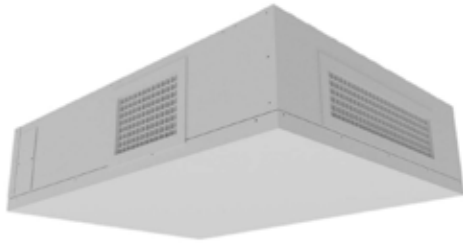

Name	Code	Installation
INDOOR HR 400C 3E	70IHR04C03E0000	horizontal on ceiling
INDOOR HR 400C EB	70IHR04C0EB0000	

FEATURES

- Nominal air flow rate: 400 m³/h
- Elect. power supply 230 Vac - 50/60 Hz
- Weight: 90 Kg

PERFORMANCE

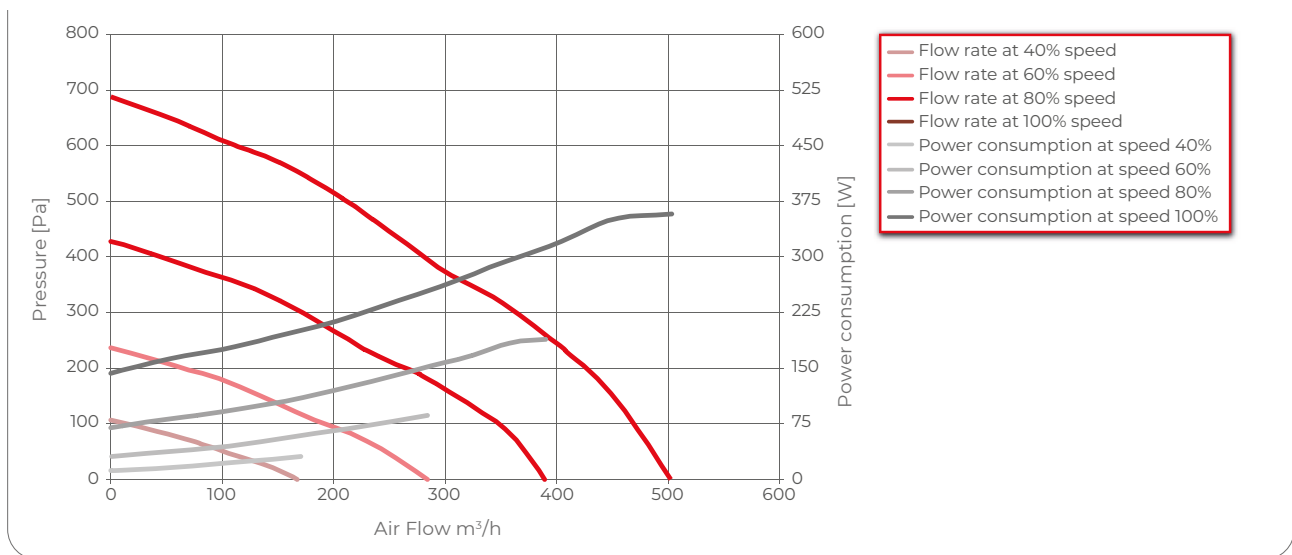

CONNECTIONS AND SIZES

- Air duct connections Ø 200 mm
- Condensate drain Ø 20 mm

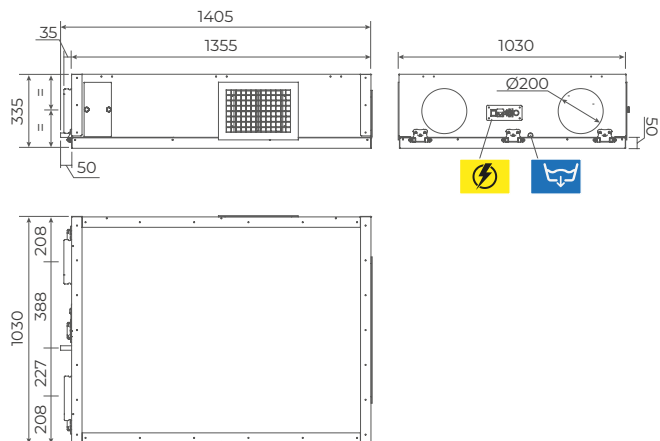



Name	Code	Installation
INDOOR HR 400F 3E	70IHR04F13E0000	vertical on floor
INDOOR HR 400F EB	70IHR04F1EB0000	

FEATURES

- Flow rate up to 520 m³/h, head up to 680 Pa
- Elect. power supply 230 Vac - 50/60 Hz
- Weight: 115 Kg

PERFORMANCE

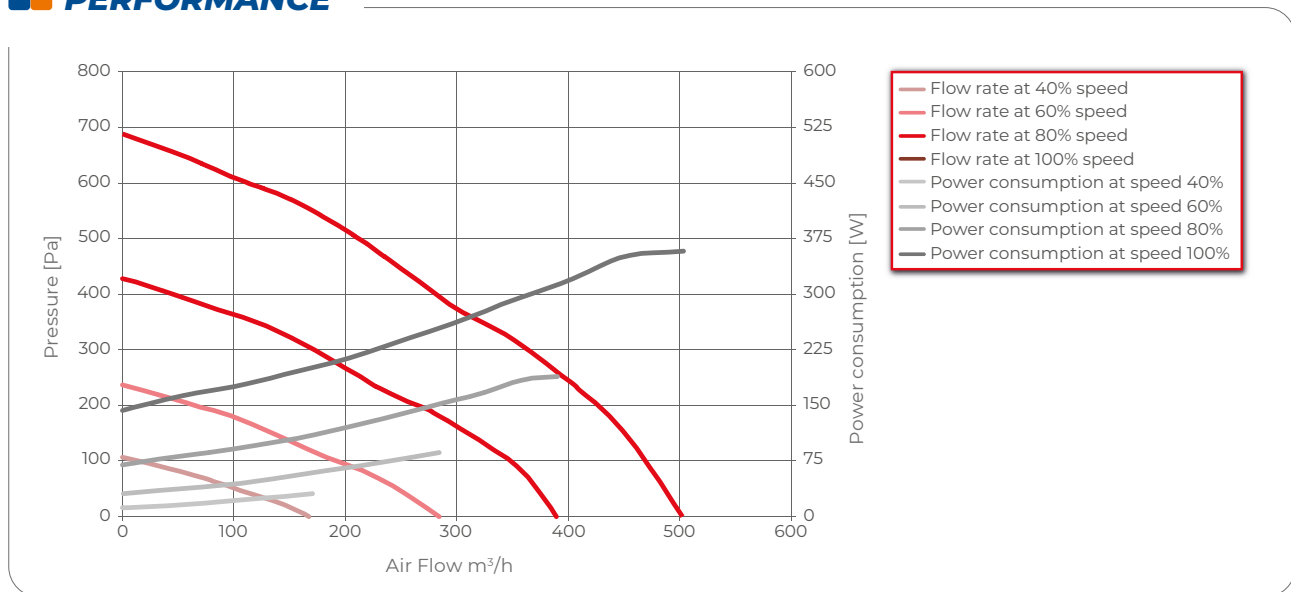

CONNECTIONS AND SIZES

- Air duct connections Ø 200 mm
- Condensate drain Ø 20 mm

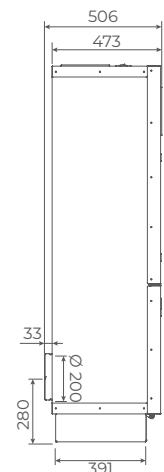
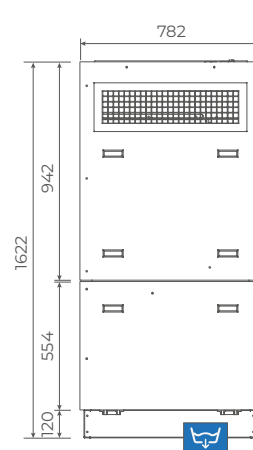
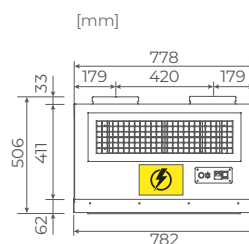



Name	Code	Installation
INDOOR HR 1000C 3E	70IHR10C03E0000	horizontal on ceiling
INDOOR HR 1000C EB	70IHR10C0EB0000	

FEATURES

- Flow rate up to 1050 m³/h, head up to 500 Pa
- Elect. power supply 230 Vac - 50/60 Hz
- Weight: 148 Kg

PERFORMANCE

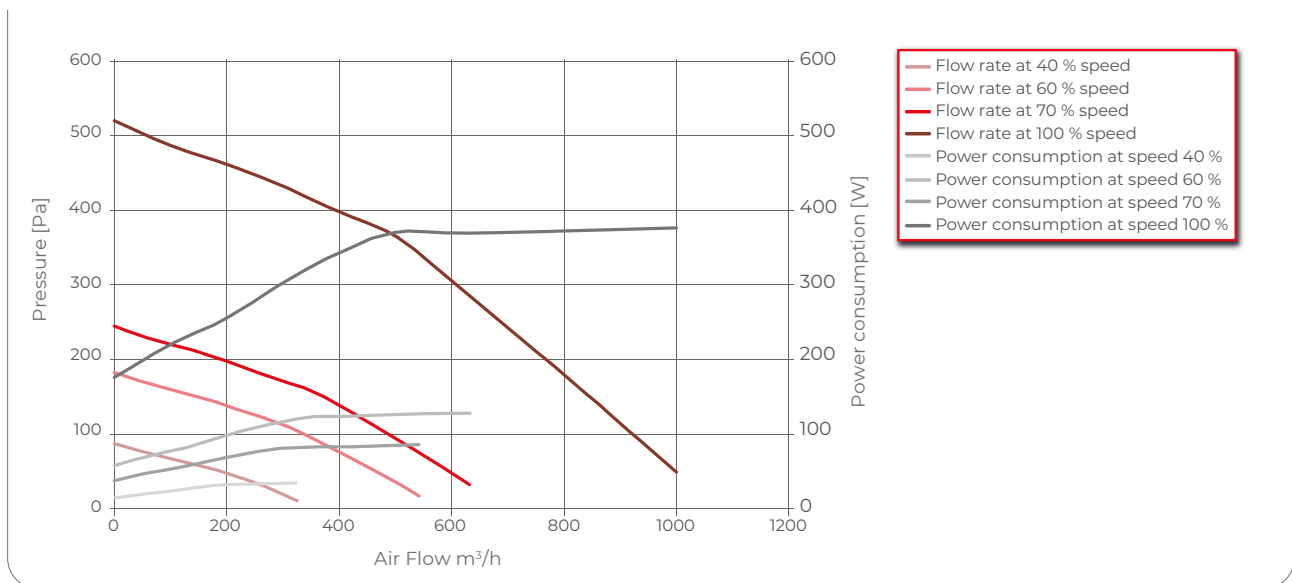

CONNECTIONS AND SIZES

- Air duct connections Ø 315 mm
- Condensate drain Ø 20 mm

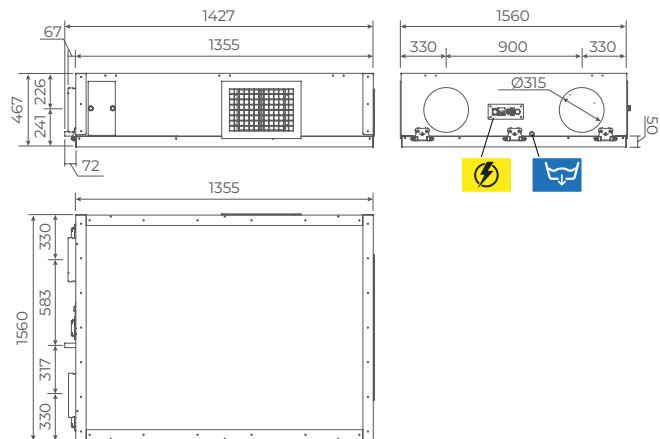



Name	Code	Installation
INDOOR HR 1000F 3E	70IHR10F13E0000	vertical on floor
INDOOR HR 1000F EB	70IHR10F1EB0000	

FEATURES

- Flow rate up to 1050 m³/h, head up to 500 Pa
- Elect. power supply 230 Vac - 50/60 Hz
- Weight: 162 Kg

PERFORMANCE

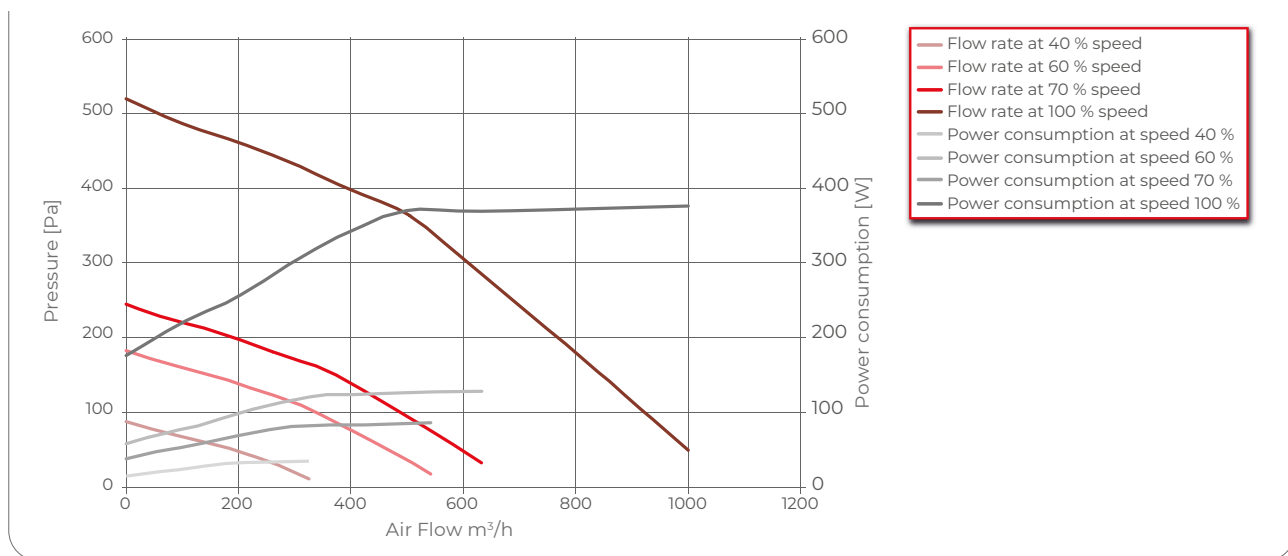

CONNECTIONS AND SIZES

- Air duct connections Ø 250 mm
- Condensate drain Ø 20 mm

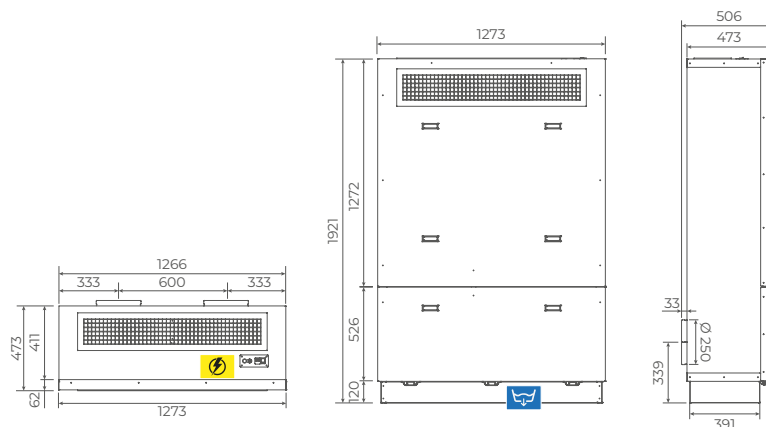

■ ■ COMPLEMENTS

	<i>Optional</i>					
						
Name	RE-M	QA probe	Pressostat	UV lamp	Filter Kits	
	Modulating electric heater				Indoor HR 400	Indoor HR 1000



Air dehumidification





The best climate even in summer

Our radiant floor, ceiling and wall systems can also be used with excellent results for winter heating, and **summer cooling** too.

In summer, however, in order to maintain room comfort and avoid the risk of condensation, it is essential to keep the air humidity under control.

For this reason, we offer **complete range of dehumidifiers** which meet all specific design and application requirements.

Every machine has a refrigeration unit with two additional heat exchangers, exploiting the availability of the cold water (15-18 °C) that is used in the radiant panels.

The pre-condensation water battery lowers the air temperature and reduce the sensible heat just before the evaporation coil, while the post-condensation battery lowers the air temperature before supplying it back to the rooms.

As a result, this air treatment allows to control the latent heat and supply dehumidified neutral air to the rooms.

This system also ensures higher efficiency of the chiller, because it can provide water at a higher temperature to radiant panels than the one which is usually necessary for the dehumidification

ADVANTAGES OF AIR DEHUMIDIFICATION



**INDOOR COMFORT
DURING SUMMER**



**INTEGRATION OF SENSIBLE HEAT
(RNW 200, 411 AND 508)**



**AVOID CONDENSATION
ISSUES**



**WIDE RANGE
OF MODELS**



**SILENCE FUNCTIONING AND
COMPACT DIMENSIONS**



**INSTALLATION VERSATILITY:
EMBEDDED, ON WALL, ON FALSE CEILING**



MODEL	CODE
RNW 200 P	70RNWP0200

An isothermal dehumidifier designed and sized for the control of ambient relative humidity in radiant floor/ceiling/wall cooling systems. It consists of a complete refrigeration unit and is equipped with pre-treatment and post-treatment coils fed with the chilled water used in the radiant system.

The unit is available in 2 versions depending on accessories:

- in-wall version (consisting of counter casing, refrigeration unit and front panel)
- surface wall version (consisting of refrigeration unit and cabinet)

A siphon on the condensate drain must be fitted.

FEATURES

- Galvanised sheet metal structure
- Stainless steel condensate collection tray
- Finned heat exchangers with hydrophilic treatment
- Dehumidification capacity: 21 l/g (26°C RH 65%)

TECHNICAL DATA

- Size l x h x d: 721 x 571 x 200 mm
- Max. electrical power: 340 W
- Elect. power supply: 230 Vac - 50/60 Hz
- Water flow rate at 15 °C: 240 l/h
- Nominal Air flow rate: 160 m³/h
- Refrigerant: R290 - GWP: 3 (70 g)

PERFORMANCE

Air		Water	Summary				
160 m ³ /h		240 l/h					
Pre-Treatment		[REC] Inlet Temp.	Dehumidification				
[REC] Inlet Temp.	[REC] Inlet R.H.		Condensation	Power		Total Power	
(°C)	(%)	(°C)		(l/g)	Latent	Sensible	Room
				(W)	(W)	(W)	(W)
26	65	18	21	601	97	698	781
		15	25	735	200	934	1088
		12	30	516	324	840	1395
25	55	18	14	396	92	487	586
		15	16	459	162	621	642
		12	21	542	324	865	949
27	60	18	20	578	130	707	698
		15	25	721	270	991	949
		12	29	864	394	1258	1228



SUMMER SENSIBLE POWER INTEGRATION: 860 W



MODEL	CODE
RNW 200 PI	70RNWPI200

An isothermal dehumidifier designed and sized for the control of ambient relative humidity in radiant floor/ceiling/wall cooling systems. It consists of a complete refrigeration unit and is equipped with pre-treatment and post-treatment coils fed with the chilled water used in the radiant system.

The unit is available in 2 versions depending on accessories:

- in-wall version (consisting of counter casing, refrigeration unit and front panel)
- surface wall version (consisting of refrigeration unit and cabinet)

A siphon on the condensate drain must be fitted.

FEATURES

- Galvanised sheet metal structure
- Stainless steel condensate collection tray
- Finned heat exchangers with hydrophilic treatment
- Dehumidification capacity: 2l/g (26°C RH 65%)
- Summer sensible power integration: 860 W

TECHNICAL DATA

- Size l x h x d: 721x573x200 mm
- Max. electrical power: 340 W
- Elect. power supply: 230 Vac - 50/60 Hz
- Water flow rate at 15 °C: 240 l/h
- Nominal Air flow rate: 160 m³/h
- Refrigerant: R290 - GWP: 3 (70 g)

PERFORMANCE

Air		Water	Summary										
160 m ³ /h		240 l/h											
Pre-Treatment		[REC] Inlet Temp.	Dehumidification					Integration					
[REC] Inlet Temp.	[REC] Inlet R.H.		Condensation	Power		Total Power		[SUP] Temp.	[SUP] R.H.	Power		Total Power	
(°C)	(%)			Lat.	Sen.	Room	Fridge group			Lat.	Sen.	Room	Fridge group
26	65	18	21	601	97	698	781	18,0	74	601	434	1035	1507
		15	25	735	200	934	1088	16,2	72	735	529	1264	1737
		12	30	516	324	840	1395	14,2	72	516	638	1154	1102
25	55	18	14	396	92	487	586	17,9	62	396	383	779	1361
		15	16	459	162	621	642	16,7	63	459	448	907	1479
		12	21	542	324	865	949	14,7	63	542	556	1097	1708
27	60	18	20	578	130	707	698	19,9	64	578	383	961	1537
		15	25	721	270	991	949	18,0	64	721	486	1206	1774
		12	29	864	394	1258	1228	15,9	63	864	599	1463	2035

INSTALLATION

- Vertical wall-mounted (1)
- Vertical wall recessed (2)

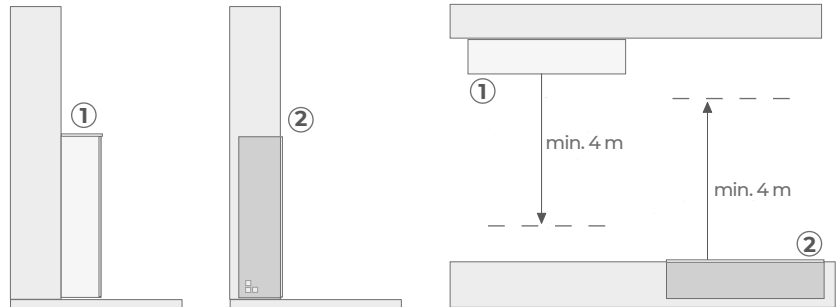

CONNECTIONS AND FILTERS

- Hydraulic connections 1/2" G F
- Condensate drain Ø 14 mm

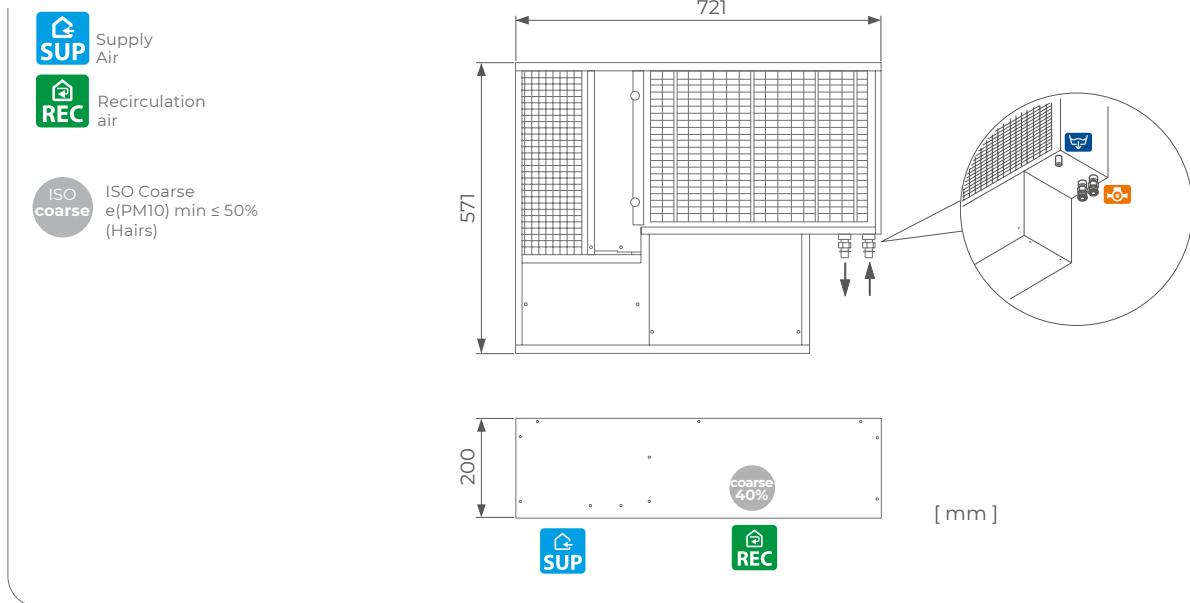

COMPLEMENTS

	Accessories	Accessories for recessed installation		Accessories for wall installation
Name	MP 2-8 Flow meter	Recessed box	Front panel	Cabinet
Page	111	59	59	59

RNW - recessed box



SIZE l x h x p mm	CODE
760x619x206	7040015

Embedded box in galvanized steel plate with holes for electrical and hydraulic connections.

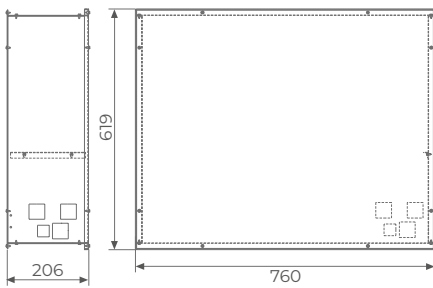

RNW - front panel



SIZE l x h x p mm	CODE
790x630x18	7040025

Front panel in white lacquered MDF wood. Air Grille in anodized aluminium.

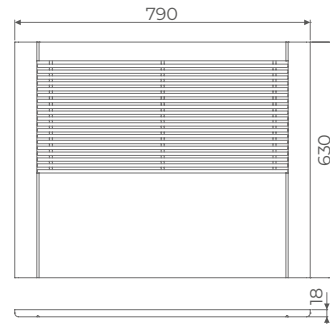

RNW - cabinet



SIZE l x h x p mm	CODE
796x649x229	7040031

Cabinet for wall installation in matt white lacquered MDF including a front panel. Air Grille in anodized aluminium.

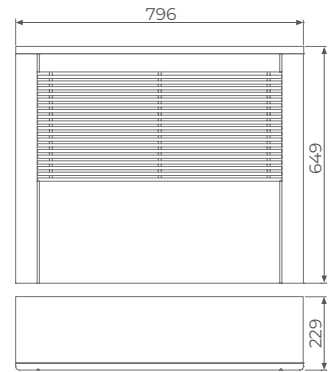

[mm]



MODEL	CODE
RNW 404 Core	7040032

Ductable isothermal dehumidifier designed for horizontal ceiling installation. It consists of a complete cooling unit (with refrigerant R290), centrifugal fan and pre- and post-treatment coils to be supplied with cooled water (15 °C). It is mandatory to use 1 condensate drain kit (SF-M or SF-P N).

FEATURES

- Galvanised sheet metal structure
- Stainless steel condensate collection tray
- Finned heat exchangers with hydrophilic treatment
- Dehumidification capacity: 26.6 l/g
- Removable electrical box

TECHNICAL DATA

- Size l x h x d: 721 x 247 x 550 mm
- Max. electrical power: 360 W
- Elect. power supply 230 Vac - 50/60 Hz
- Water flow rate at 15 °C: 240 l/h
- Nominal Air flow rate: 200 m³/h
- Refrigerant: R134a (220 g)

CONNECTIONS AND FILTERS

- Air duct connections:
SUP 416 x 213 mm or supply plenum (see complements)
REC 452 x 117 mm
- Hydraulic connections: 1/2" G F
- Condensate drain Ø 14 mm



Supply Air



Recirculation air



ISO Coarse e(PM10) min ≤ 50% (Hairs)

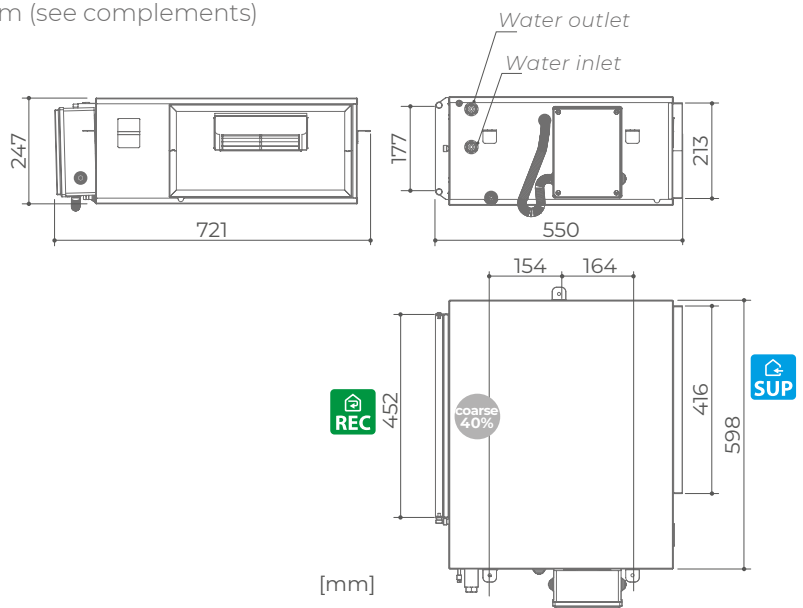

[mm]



INSTALLATION

- Horizontal ceiling mounted
- Slope 2%



Unit weight

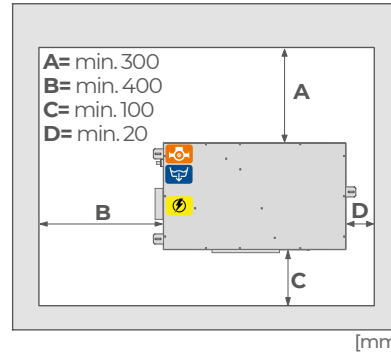
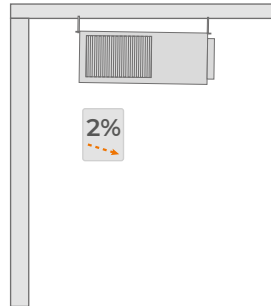

- Hydraulic connection
- Condensate drain
- Wiring Box

PERFORMANCE

Performance in dehumidification mode

Water temp.	Room temperature: 26 °C		Room temperature: 24 °C	
	55% RH (L/g)	65% RH (L/g)	55% RH (L/g)	65% RH (L/g)
18	17.8	21.9	13.4	18.8
15	21.0	26.6	16.9	23.1

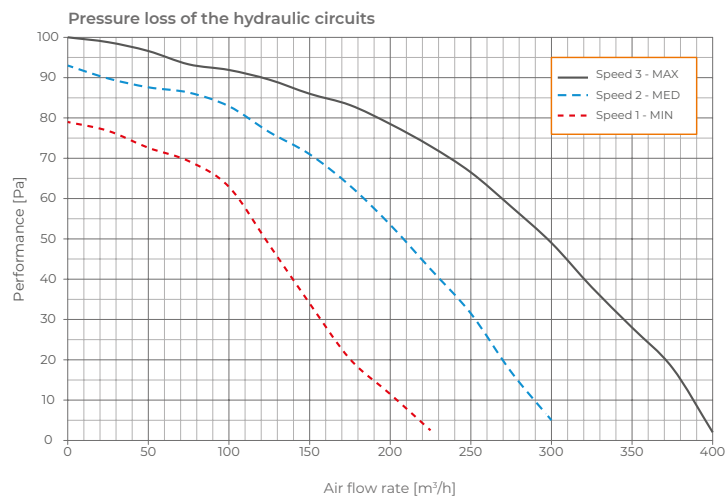
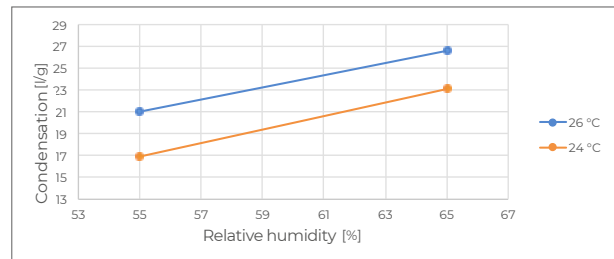
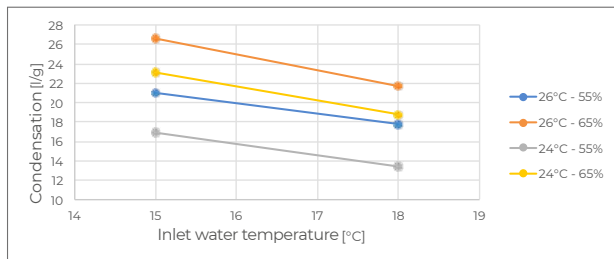

COMPLEMENTS

	Accessories	Optional			Siphon
Name	MP 2-8 Flow meter	Supply plenum box for RNW 404 / 411	Collar Ø 100	Collar Ø 160	SF-P N Sifowall
Page	111				110

SUMMER SENSIBLE POWER INTEGRATION: 1130 W



MODEL	CODE
RNW 411 Core	7041401

Ductable isothermal dehumidifier designed for horizontal ceiling installation. It consists of a complete cooling unit (with refrigerant R290), centrifugal fan and pre- and post-treatment coils to be supplied with cooled water (15 °C). It is mandatory to use 1 condensate drain kit (SF-M or SF-P N).

FEATURES

- Galvanised sheet metal structure
- Stainless steel condensate collection tray
- Finned heat exchangers with hydrophilic treatment
- Dehumidification capacity: 32.2 l/g (26°C 65% RH)
- Summer sensible power integration: 1200 W

TECHNICAL DATA

- Size l x h x d: 721 x 247 x 605 mm
- Max. electrical power: 520 W
- Elect. power supply 230 Vac - 50/60 Hz
- Water flow rate 25 °C 240 l/h
- Nominal Air flow rate: 200 m³/h
- Refrigerant: R134a (190 g)

CONNECTIONS AND FILTERS

- Air duct connections:
- SUP 416 x 211 mm or supply plenum (see complements)
- REC 450 x 177 mm
- Hydraulic connections: 1/2" G F
- Condensate drain Ø 14 mm

- Supply Air
- Recirculation air
- ISO Coarse e(PM10) min ≤ 50% (Hairs)

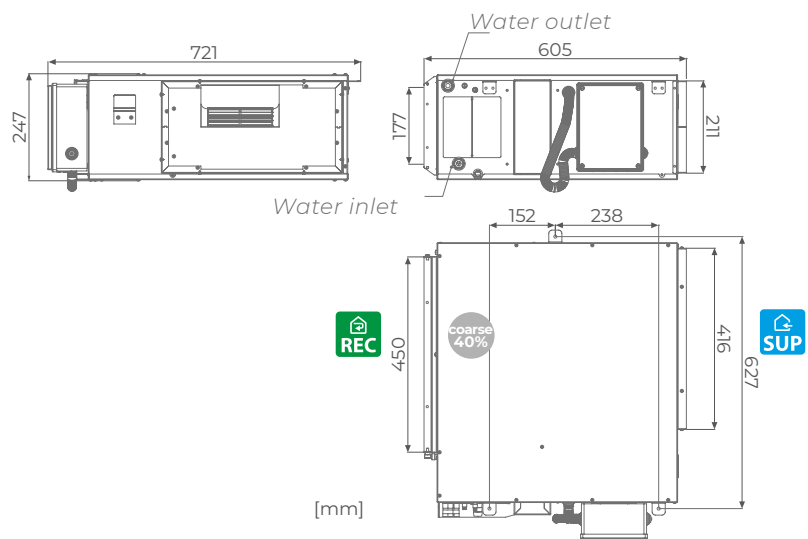



INSTALLATION

- Horizontal ceiling mounted
- Slope 2%



Unit weight

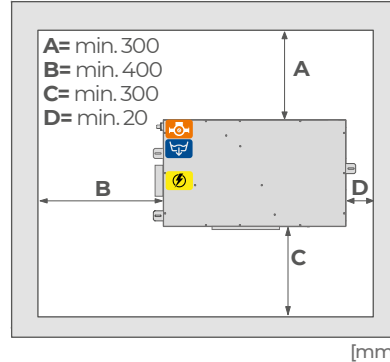
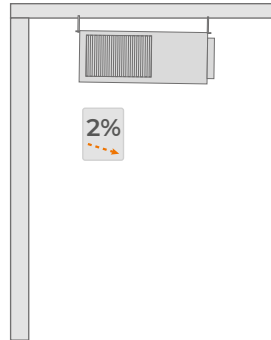

- Hydraulic connection
- Condensate drain
- Wiring Box

PERFORMANCE

Performance in dehumidification mode (200 m³/h)

Inlet air		Outlet air		Latent cooling power	
°C	%	°C	%	W	l/g
26	55	26	37.5	644	22.3
26	65	26	39.5	932	32.2

Performance in integration (300 m³/h)

Inlet air		Outlet air		Latent cooling power		Sensible power
°C	%	°C	%	W	l/g	W
26	55	13.1	97	629	21.7	1353
26	65	14.2	97	990	34.2	1235

Available pressure to the intake outlet

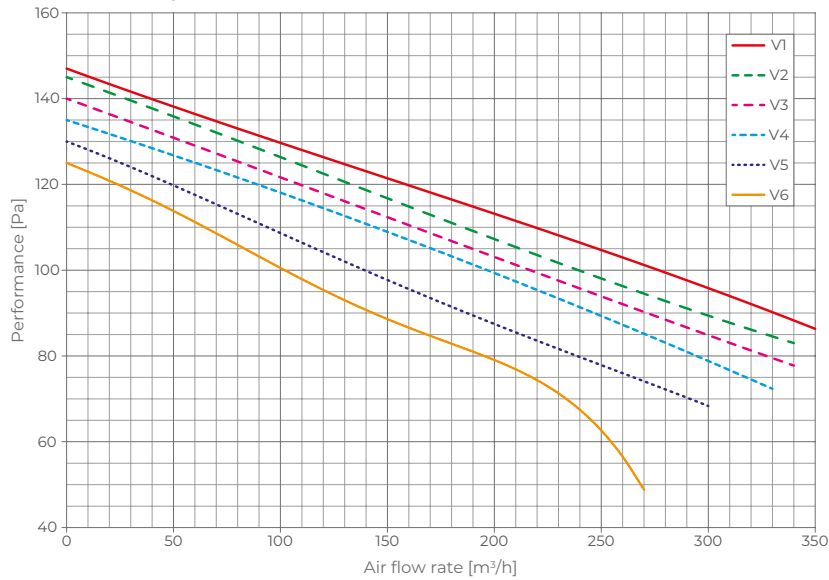

COMPLEMENTS

	Accessories	Optional			Siphon
Name	MP 2-8 Flow meter	Supply plenum box for RNW 404 / 411	Collar Ø100	Collar Ø160	SF-P N Sifowall
Page	111				110

SUMMER SENSIBLE POWER INTEGRATION: 1600 W



MODEL	CODE
RNW 508	7040050

Ductable isothermal dehumidifier with summer and winter integration for horizontal ceiling installation. It consists of a complete cooling unit (with refrigerant R134a), centrifugal fan and pre- and post-treatment coils to be supplied separately with cooled water (15 °C). It is mandatory to use 1 condensate drain kit (SF-M or SF-P N).

FEATURES

- Galvanised sheet metal structure
- Stainless steel condensate collection tray
- Finned heat exchangers with hydrophilic treatment
- Dehumidification capacity: 42 l/g (26 °C RH 65%)
- Summer sensible power integration: 1600W

TECHNICAL DATA

- Size l x h x d: 825x287x585 mm
- Max. electrical power: 500 W
- Elect. power supply 230 Vac - 50 Hz
- Pre-treatment water flow at 15 °C 360 l/h
- Post-treatment water flow at 15 °C 170 l/h
- Nominal Air flow rate: 515 m³/h
- Refrigerant: R134a (300 g)

CONNECTIONS AND FILTERS

- Air duct connections:
SUP 302x232 mm
REC 508x226 mm
- Water exit pre-treatment 1/2" G F
- Water exit post-treatment 1/2" G F
- Condensate drain Ø 20 mm

- Supply Air
- Recirculation air
- ISO Coarse e(PM10) min ≤ 50% (Hairs)

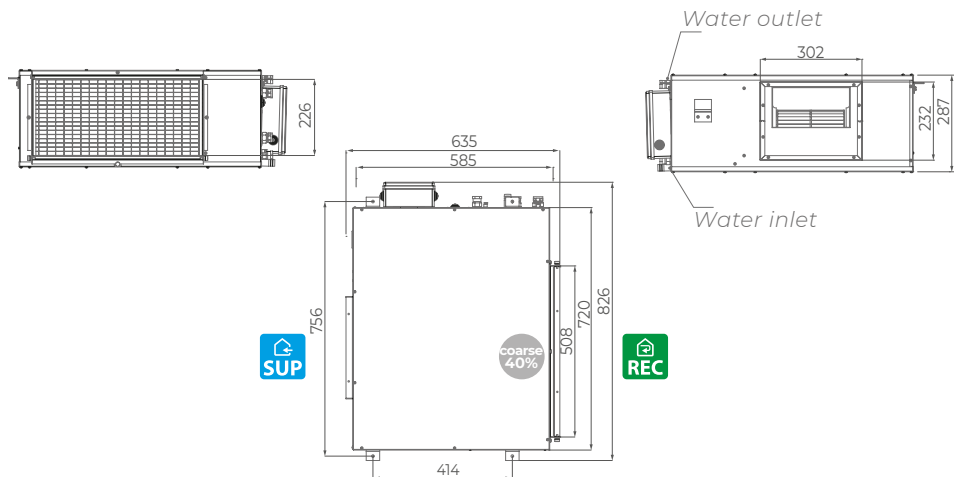



INSTALLATION

- Horizontal ceiling mounted
- Slope 2%



Unit weight

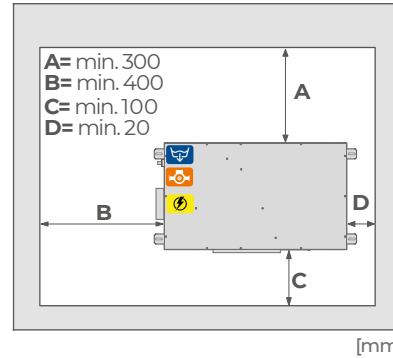
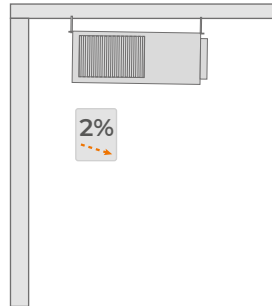

- Hydraulic connection
- Condensate drain
- Wiring Box

PERFORMANCE

Power and cooling performance in dehumidification

Room Temperature	Relative Humidity	Inflow Water Temperature	Water Flow on pre-treatment Coil	Water Flow on post-treatment Coil	Refrigerating Power Coil	Sensible power	Latent power subtracted from the air	Water Condensation
------------------	-------------------	--------------------------	----------------------------------	-----------------------------------	--------------------------	----------------	--------------------------------------	--------------------

Performance in dehumidification mode

(°C)	%	(°C)	(l/min)	(l/min)	(KW)	(KW)	(KW)	(l/day)
26	55	7	1,1	-	1,11	-	0,66	22,5
		15	3,0	-	1,07	-	0,64	21,6
		18	6,0	-	1,02	-	0,61	20,7
	65	7	1,8	-	1,64	-	1,25	42,3
		15	4,8	-	1,52	-	1,15	38,9
		18	6,0	0,60	1,28	-	0,87	29,4
24	55	7	0,9	-	0,91	-	0,54	18,1
		15	3,6	-	0,97	-	0,54	18,1
		18	6,0	0,36	0,93	-	0,43	14,7
	65	7	1,8	-	1,43	-	1,02	34,6
		15	6,6	-	1,28	-	0,92	31,1
		18	6,0	1,50	1,11	-	0,69	23,3

Performance with emission of sensible heat into the room

(°C)	%	(°C)	(l/min)	(l/min)	(KW)	(KW)	(KW)	(l/day)
26	55	7	6,0	2,8	3,66	1,67	1,58	53,6
		12	6,0	2,8	2,55	1,05	1,05	35,4
		15	6,0	2,8	1,89	0,70	0,74	25,1
	65	7	6,0	2,8	4,07	1,49	2,17	73,4
		12	6,0	2,8	2,97	0,89	1,63	55,3
		15	6,0	2,8	2,26	0,55	1,25	42,3
24	55	7	6,0	2,8	3,15	1,47	1,28	43,2
		12	6,0	2,8	2,07	0,85	0,79	26,8
		15	6,0	2,8	1,56	0,54	0,59	19,9
	65	7	6,0	2,8	3,55	1,33	1,81	61,3
		12	6,0	2,8	2,44	0,74	1,28	43,2
		15	6,0	2,8	1,73	0,36	0,92	31,1

PERFORMANCE

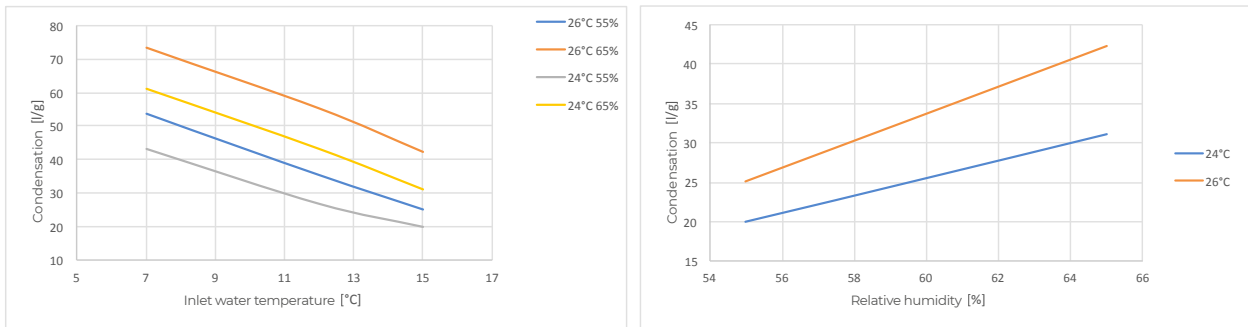

Ventilator RNW 508 characteristics curve

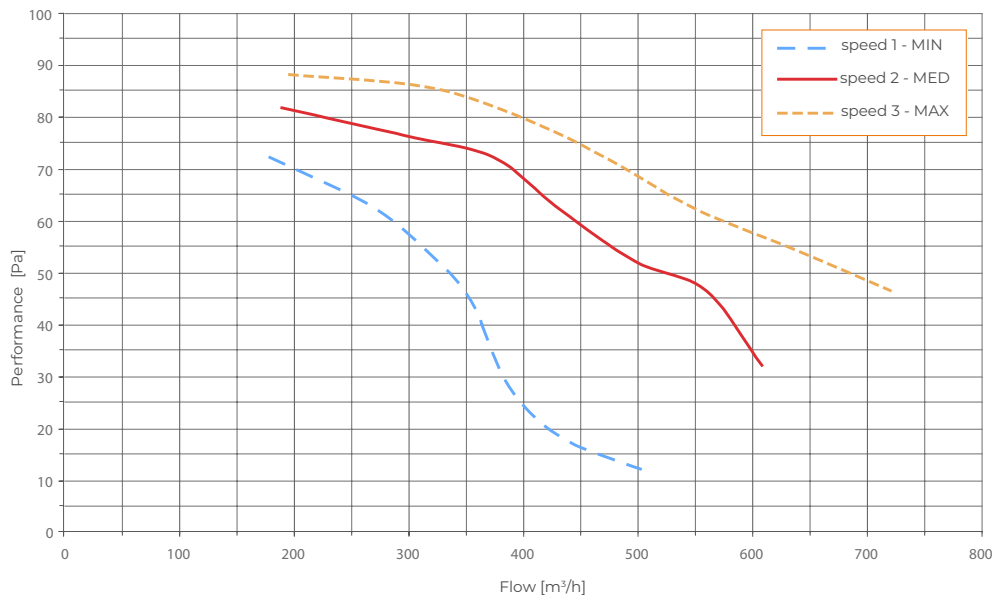

COMPLEMENTS

	Accessories	Siphon
		
Name	MP 2-12 Flow meter	SF-P N Sifowall
Page	111	110

Selection guide

Air dehumidification

For each dehumidifier, the entire room volume is assumed as air exchange rate.

Dehumidifier selection chart

RDZ model	air flow rate	max available pressure	condensation	summer integration	water flow	max number of people
	m ³ /h	Pa	L/g (*)	W	L/h (**)	no.
wall installation						
RNW 204	200		23.4		240	5
RNW 214	200		23.4	950	240	5
ceiling installation						
RNW 404	240	30	25.8		240	6
RNW 411	240	30	31.4	1200	240	6
RNW 508	500	50	42.0	1600	530	10

(*) water temperature 15° C - room temperature 26 °C - 65 % R.H.

(**) water temperature 15 °C

**FOR COMBINATION
WITH REFLAIR UNITS**



MODEL	CODE
DWF 200	7044008

Ductable isothermal dehumidification module designed for horizontal ceiling installation. It shall be combined with controlled mechanical ventilation units with suitable air flow since it does not include any fans. It consists of a refrigerant circuit (R410A) and pre and post- treatment coils to be supplied with cooled water (15 °C). It is mandatory to use 1 condensate drain kit (SF-M or SF-P N).

FEATURES

- Galvanised sheet metal structure
- Stainless steel condensate collection tray
- Finned heat exchangers with hydrophilic treatment
- Nominal air flow rate: 200 m³/h
- Dehumidification capacity: 43 l/g (33 °C 50 % RH)
- Additional sensible cooling capacity: 273 W

TECHNICAL DATA

- Size l x h x d: 552x270x635 mm
- Max. electrical power: 500 W
- Elect. power supply 230 Vac - 50 Hz
- Pre-treatment water flow at 15 °C 300 l/h
- Post-treatment water flow at 15 °C 100 l/h
- Minimum air flow rate: 150 m³/h
- Refrigerant: R134a (284 g)

CONNECTIONS AND FILTERS

- Air duct connections Ø 125 and 160 mm
- Hydraulic connections: ½" F
- Condensate drain Ø 20 mm

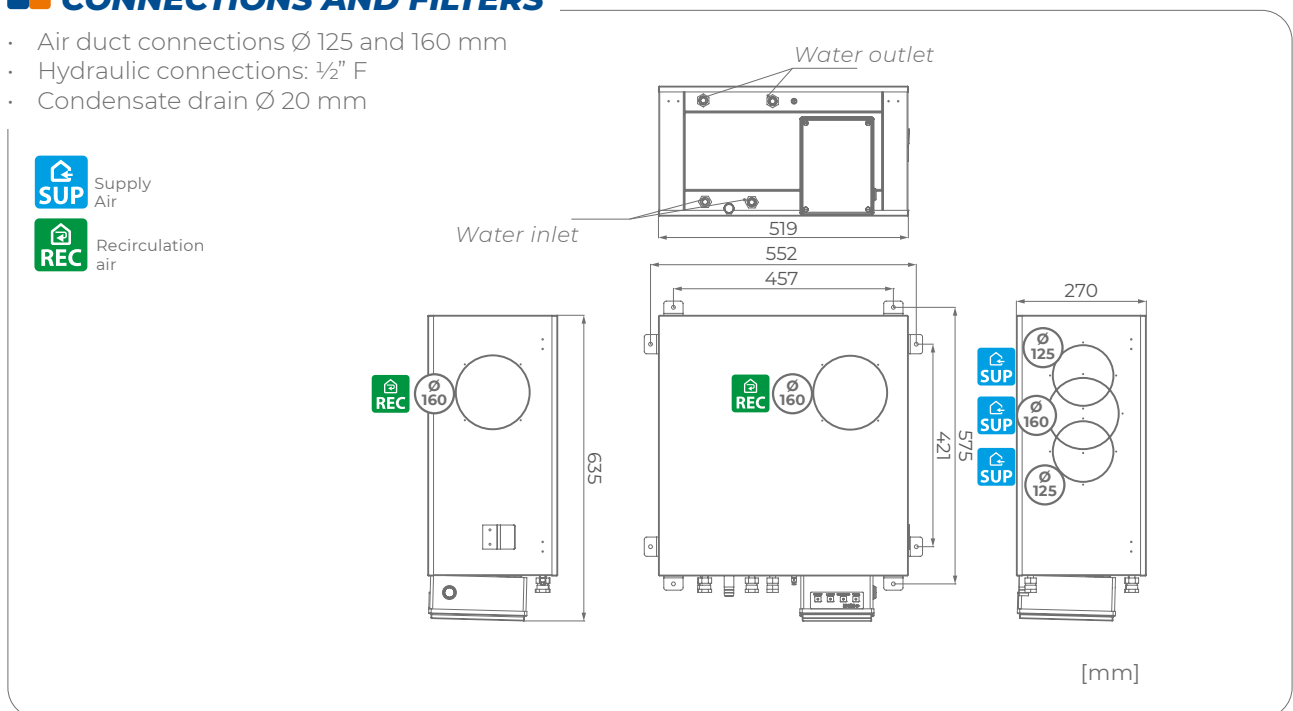



INSTALLATION

- Horizontal ceiling mounted
- Slope 2%



Unit weight

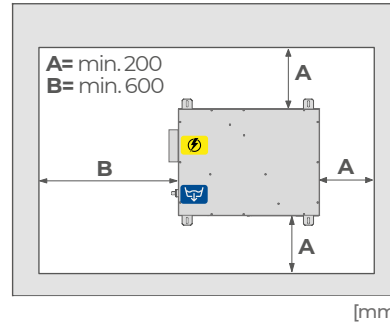
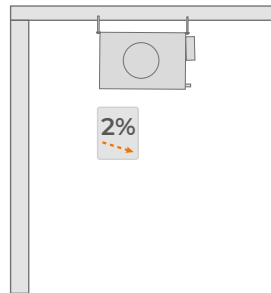

PERFORMANCE

Summer performance

Performance with water at 15 °C - Pre-treatment water flow: 300 l/h

Air flow	External air		Outlet air (POST 100 l/h)		Neutral air 25 °C		Latent cooling power		Cooling power to besupplied to the unit
					POST Flow rate	R.H.			
m³/h	°C	% RH	°C	% RH	l/h	%	W	l/g	W
150	30	50	23,0	38	62	34	866	29,9	1439
	33	50	23,4	39	70	36	1136	39,2	1714
	35	50	24,0	40	77	38	1346	46,5	1907
200	30	50	23,2	45	61	40	938	32,4	1581
	33	50	23,9	49	75	43	1273	44,0	1792
	35	50	24,5	47	87	46	1523	52,6	2137

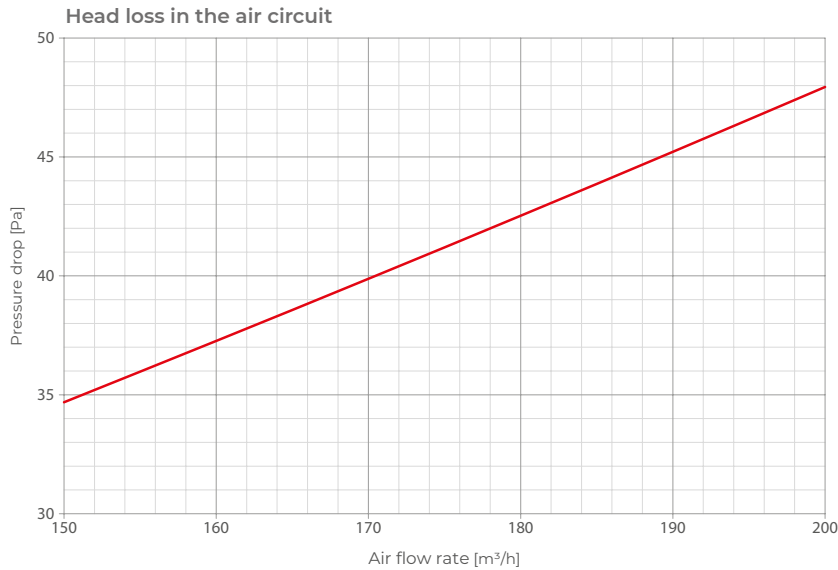

COMPLEMENTS

	Accessories			Siphon	
Name	MP 2-12 Flow meter	Collars kit Ø160-160 for DWF 200	Collars kit Ø160-125 for DWF 200	SF-M 20 Condensate drain kit	SF-P N Sifowall
Page	111			110	110

**FOR COMBINATION
WITH CHR & WHR UNITS**



MODEL	CODE
DWF 400	7044012

Ductable isothermal dehumidification module designed for horizontal ceiling installation. It shall be combined with controlled mechanical ventilation units with suitable air flow since it does not include any fans. It consists of a refrigerant circuit (R290) and pre and post- treatment coils to be supplied with cooled water (15 °C). It is mandatory to use 1 condensate drain kit (SF-M or SF-P N).

FEATURES

- Galvanised sheet metal structure
- Stainless steel condensate collection tray
- Finned heat exchangers with hydrophilic treatment
- Nominal air flow rate: 400 m³/h
- Dehumidification capacity: 76.2 l/g (33°C 50 % RH)

TECHNICAL DATA

- Size l x h x d: 550x344x635 mm
- Max. electrical power: 800 W
- Elect. power supply 230 Vac - 50 Hz
- Pre-treatment water flow at 15 °C 500 l/h
- Post-treatment water flow at 15 °C 200 l/h
- Minimum air flow rate: 300 m³/h
- Refrigerant: R410a (480 g)

CONNECTIONS AND FILTERS

- Air duct connections Ø 160 e 200 mm
- Hydraulic connections: ½" F
- Condensate drain Ø 20 mm

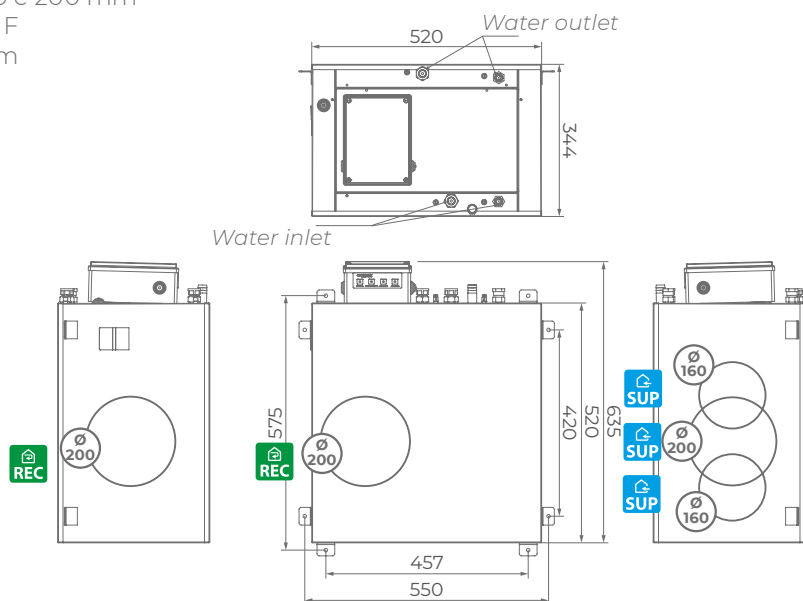

[mm]



INSTALLATION

- Horizontal ceiling mounted
- Slope 2%



Unit weight

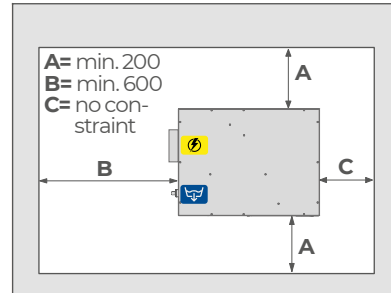
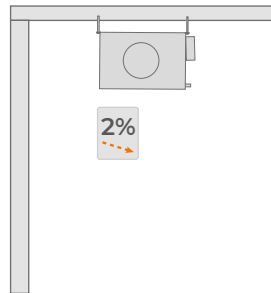

[mm]



PERFORMANCE

Summer performance

Performance with water at 15 °C - Pre-treatment water flow: 500 l/h

Air flow	External air		Outlet air (POST 100 l/h)		Neutral air 25 °C		Latent cooling power		Cooling power to besupplied to the unit
	°C	% RH	°C	% RH	POST Flow rate	R.H.	W	l/g	W
300	30	50	22,0	47	64	39	1438	49,7	2400
	33	50	22,5	48	79	41	2003	69,2	2936
	35	50	22,9	49	93	43	2398	82,8	3324
350	30	50	21,9	50	59	42	1516	52,3	2552
	33	50	22,6	52	78	45	2105	72,7	3135
	35	50	23,1	53	95	47	2582	89,2	3563
400	30	50	21,9	54	54	44	1561	53,9	2687
	33	50	22,6	55	76	48	2206	76,2	3313
	35	50	23,2	56	96	50	2709	93,5	3775

Head loss in the air circuit

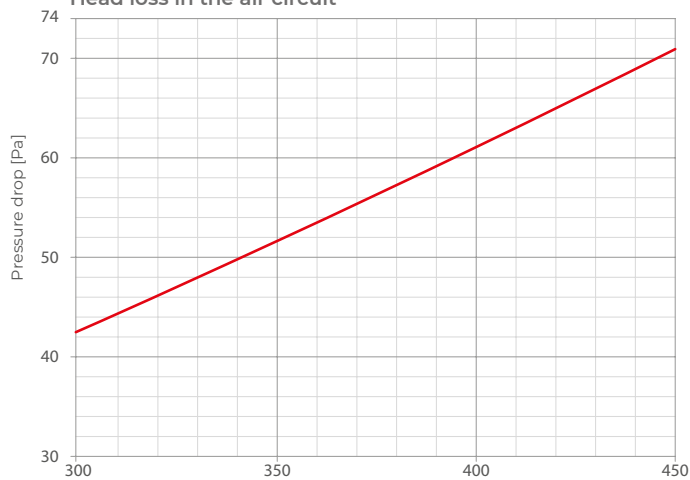

COMPLEMENTS

	Accessories			Siphon	
Name	MP 5-42 Flow meter	Collars kit Ø 200-200 for DWF 400	Collars kit Ø 200-160 for DWF 400	SF-M 20 Condensate drain kit	SF-P N Sifowall
Page	111			110	110



MODEL	CODE
DA 701	7041701

Ductable isothermal dehumidifier designed for horizontal ceiling installation. Possible operations: air circulation, summer dehumidification, additional sensible heating and cooling capacity. DA 701 dehumidifier consists of a complete cooling unit (refrigerant R410a), EC high efficiency modulating fan, pre-treatment coils and plate condenser to be supplied with cooled water (15 °C), and a display for setting and checking the parameters. The unit can be managed via digital contacts or by using Wi electronic control unit. It is mandatory to use 1 condensate drain kit (SF-M or SF-P N).

FEATURES

- Nominal air flow rate: 750 m³/h
- Available pressure: 310 Pa
- Dehum. capacity: 93.2 l/24h (26 °C RH 65% T.water 15 °C)
- Additional sensible cooling capacity up to 3165 W with supply water at 15 °C (26 °C RH 65%)
- Stainless steel condensate collection tray
- Finned heat exchangers with hydrophilic treatment

TECHNICAL DATA

- Size l x h x d: 759x388x728 mm
- Max. electrical power: 1230 W
- Elect. power supply 230 Vac - 50 Hz
- Pre-treatment water flow rate at 15 °C: 750 l/h
- Condensation water flow rate at 15 °C: 110 l/h
- Refrigerant: R410a (1060 g)

CONNECTIONS AND FILTERS

- Air duct connections: SUP 231X207 mm; REC 537X327 mm
- Pre-treatment hydraulic connections: 3/4" G F
- Post-treatment hydraulic connections: 1/2" G F
- Condensate drain Ø 20 mm

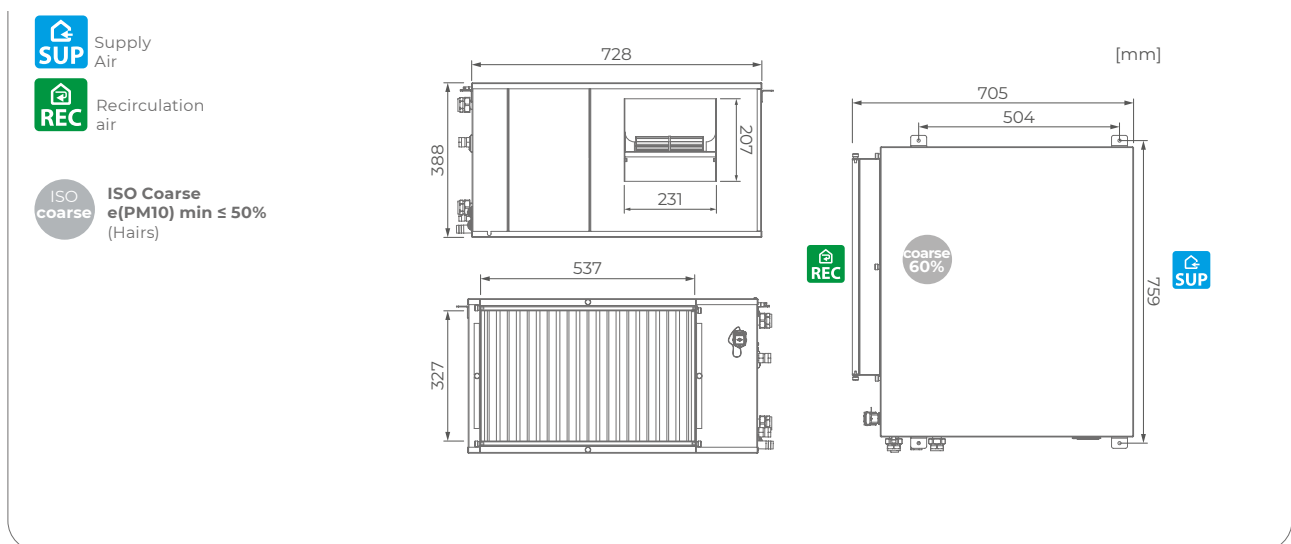



INSTALLATION

- Horizontal ceiling mounted
- Slope 2%



Unit weight

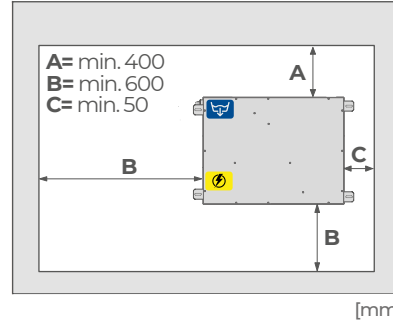
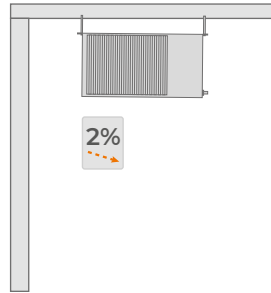

PERFORMANCE

DA 701 - Performance in dehumidification/integration mode

Air flow	Inlet air		Outlet air		Latent cooling power		Min. inflow air temp	Sens. cooling power		Cooling power to be supplied to the unit	
								Max	Set 17 °C	Dehu-mid.	Integrat.
m³/h	°C	% RH	°C	% RH	W	l/day	°C	W	W	W	W
700	26	55	26	41,3	1632	56,3	13,4	2999	2142	2259	5258
	26	65	26	43,7	2613	90,2	14,3	2796	2142	3239	6035
750	26	55	26	42,0	1659	57,3	13,6	3165	2295	2286	5451
	26	65	26	44,5	2698	93,2	14,5	2946	2295	3323	6269

Available pressures to the intake outlet

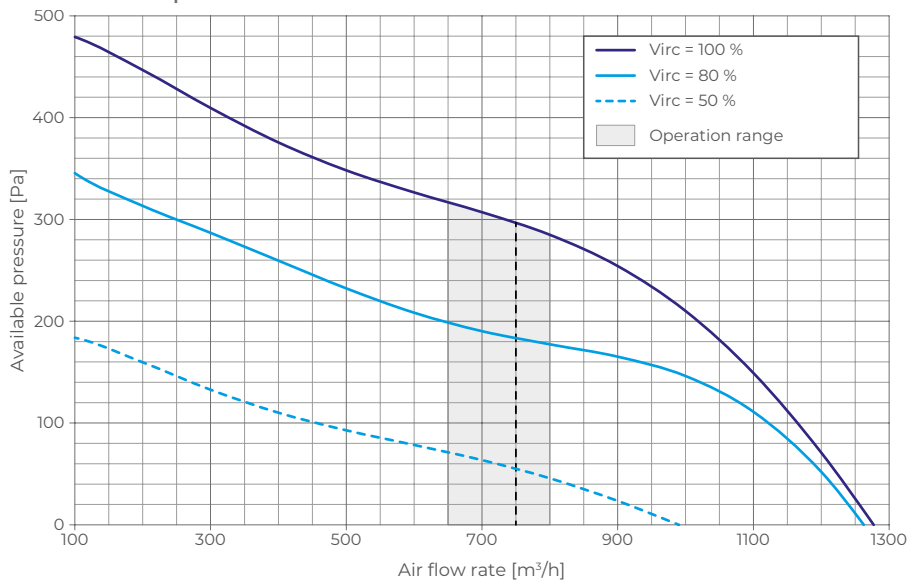

COMPLEMENTS

	Accessories			Siphons	
Name	MP 5-42 Flow meter	Modulating valve Ø 3/4"	Core Air Conv	SF-M 20 Condensate drain kit	SF-P N Sifowall
Page	111	112	104	110	110



MODEL	CODE
DA 1001	7041101

Ductable isothermal dehumidifier designed for horizontal ceiling installation. Possible operations: air circulation, summer dehumidification, additional sensible heating and cooling capacity. DA 1001 dehumidifier consists of a complete cooling unit (refrigerant R410a), EC high efficiency modulating fan, pre-treatment coils and plate condenser to be supplied with cooled water (15 °C), and a display for setting and checking the parameters. The unit can be managed via digital contacts or through Wi electronic control unit. It is mandatory to use 1 condensate drain kit (SF-M or SF-P N).

FEATURES

- Nominal air flow rate: 1000 m³/h
- Available pressure: 375 Pa
- Dehum. capacity: 127.5 l/24h (26 °C RH 65% T.water 15 °C)
- Additional sensible cooling capacity up to 3994 W with supply water at 15 °C (26 °C RH 65%)
- Stainless steel condensate collection tray
- Finned heat exchangers with hydrophilic treatment

TECHNICAL DATA

- Size l x h x d: 939 x 393 x 705 mm
- Max. electrical power: 2040 W
- Elect. power supply 230 Vac - 50 Hz
- Pre-treatment water flow rate at 15 °C: 1000 l/h
- Condensation water flow rate at 15 °C: 130 l/h
- Refrigerant: R410a (1250 g)

CONNECTIONS AND FILTERS

- Air duct connections REC: 716x327 mm; SUP: 231x207 mm
- Pre-treatment hydraulic connections: 3/4" G F
- Post-treatment hydraulic connections: 1/2" G F
- Condensate drain Ø 20 mm

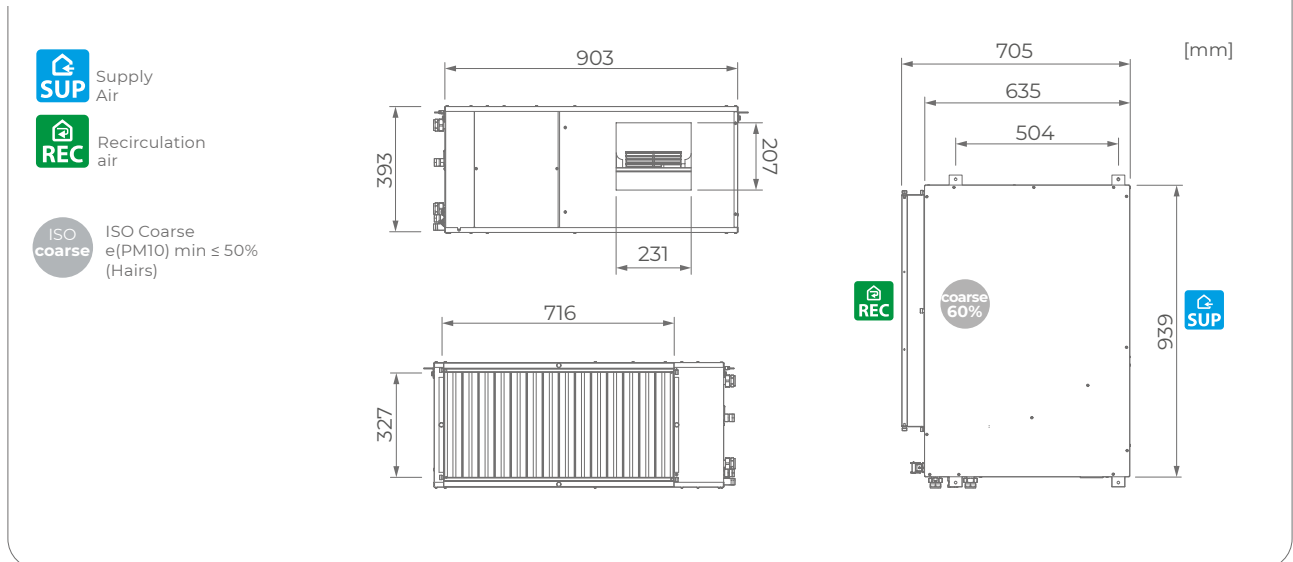



INSTALLATION

- Horizontal ceiling mounted
- Slope 2%

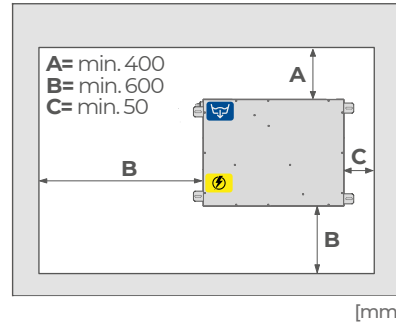
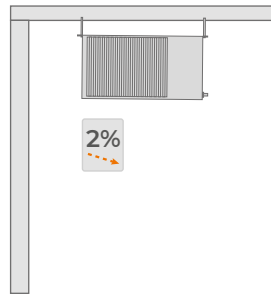

PERFORMANCE

DA 1001 - Performance in dehumidification/integration mode

Inlet air		Outlet air		Latent cooling power		Min. inflow air temp	Sens. cooling power		Cooling power to be supplied to the unit	
°C	% RH	°C	% RH	W	l/day		Max	Set 17 °C	Dehumid.	Integrat.
26	55	26	42,5	2262	78,1	14,6	3994	3150	4122	8116
26	65	26	44,8	3692	127,5	15,4	3714	3150	5552	9266

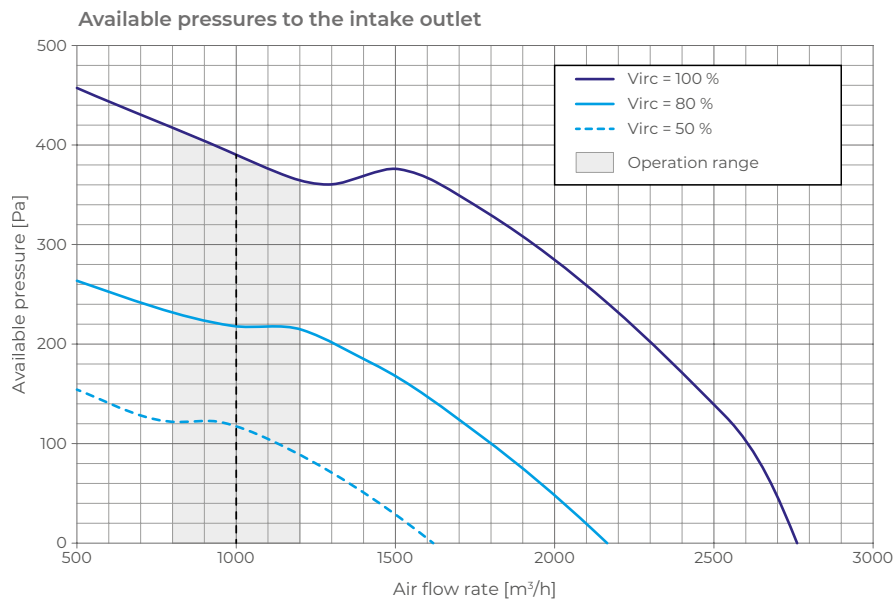

COMPLEMENTS

	Accessories			Siphons	
Name	MP 5-42 Flow meter	Modulating valve Ø 3/4"	Core Air Conv	SF-M 20 Condensate drain kit	SF-P N Sifowall
Page	111	112	104	110	110



MODEL	CODE
DA 2001	7041501

Ductable isothermal dehumidifier designed for horizontal ceiling installation. Possible operations: air rirculation, summer dehumidification, additional sensible heating and cooling capacity. DA 2001 dehumidifier consists of a complete cooling unit (refrigerant R410a), EC high efficiency modulating fan, pre-treatment coils and plate condenser to be supplied with cooled water (15 °C), and a display for setting and checking the parameters. The unit can be managed via digital contacts or through Wi electronic control unit. It is mandatory to use 1 condensate drain kit (SF-M or SF-P N).

FEATURES

- Nominal air flow rate: 2000 m³/h
- Available pressure: 365 Pa
- Dehum. capacity: 246.0 l/24h (26 °C RH 65% T.acqua 15 °C)
- Additional sensible cooling capacity up to 8456 W with supply water at 15 °C (26 °C RH 65%)
- Stainless steel condensate collection tray
- Finned heat exchangers with hydrophilic treatment

TECHNICAL DATA

- Size l x h x d: 1092 x 535 x 798 mm
- Max. electrical power: 3070 W
- Elect. power supply 230 Vac - 50 Hz
- Pre-treatment water flow rate at 15 °C: 2000 l/h
- Condensation water flow rate at 15 °C: 250 l/h
- Refrigerant: R410a (2500 g)

CONNECTIONS AND FILTERS

- Air duct connections REC: 817x470 mm; SUP: 231x207 mm
- Pre-treatment hydraulic connections: 1" G F
- Post-treatment hydraulic connections: ½" G F
- Condensate drain Ø 20 mm

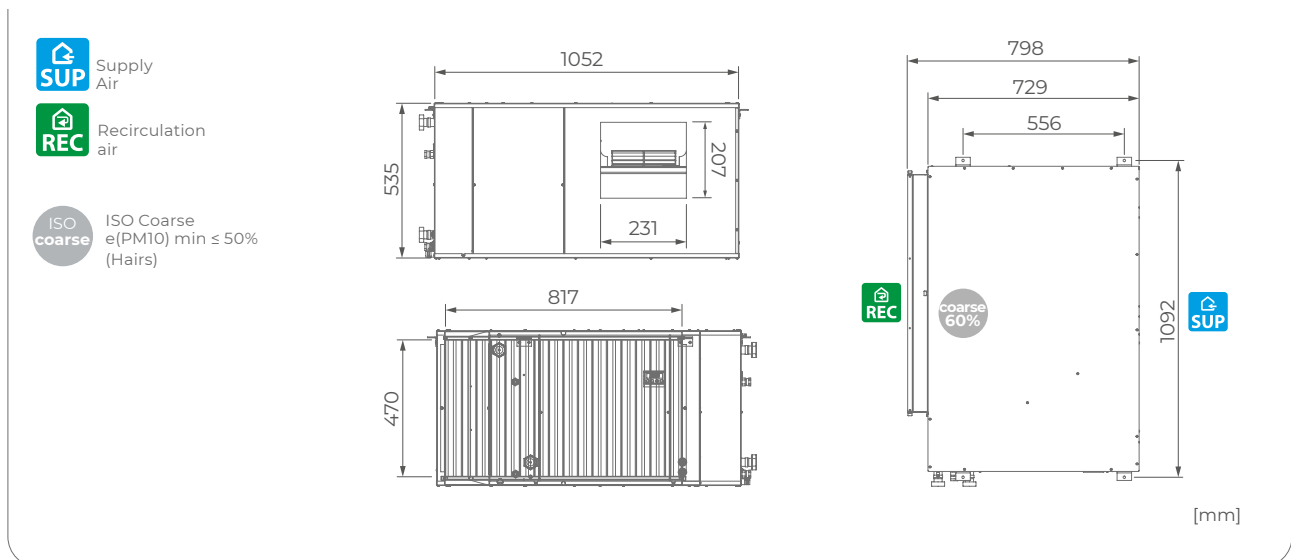



INSTALLATION

- Horizontal ceiling mounted
- Slope 2%

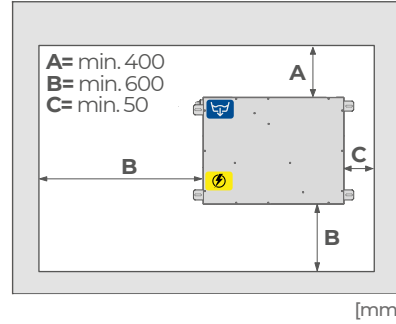
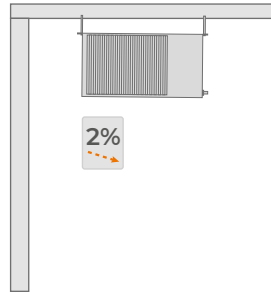

PERFORMANCE

DA 2001 - Performance in dehumidification/integration mode

Inlet air		Outlet air		Latent cooling power		Min. inflow air temp	Sens. cooling power		Cooling power to be supplied to the unit	
°C	% RH	°C	% RH	W	l/g		Max	Set 17 °C	Dehumid.	Integrat.
26	55	26	43,2	4300	148,5	13,9	8456	6300	7430	15886
26	65	26	45,8	7030	242,8	14,8	7812	6300	10161	17973

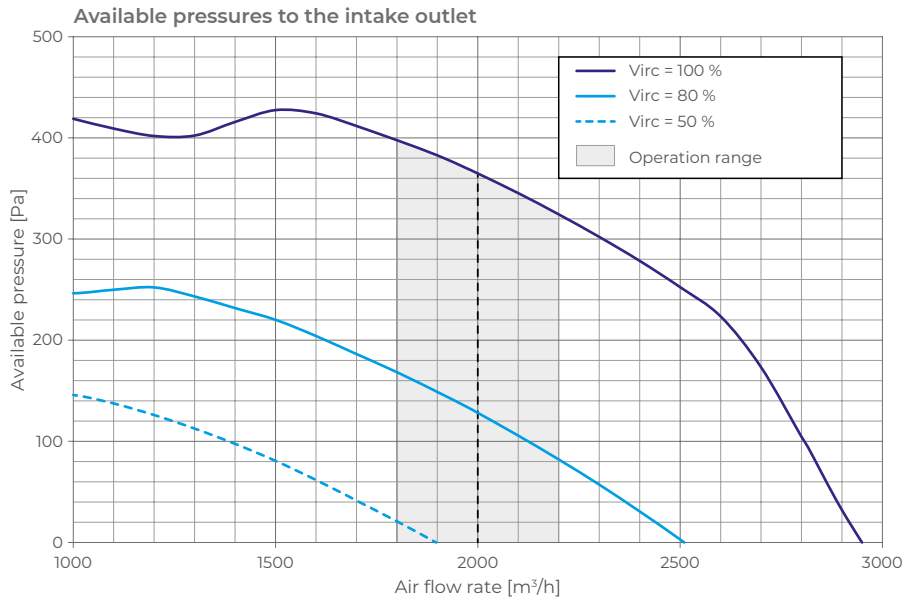

COMPLEMENTS

	Accessories			Siphons	
Name	MP 20-70 Misuratore di portata	Valvola modulante Ø1"	Core Air Conv	SF-M 20 Condensate drain kit	SF-P N Sifowall
Page	111	112	104	110	110



***Fresh air ventilation
with dehumidification***



Clean and fresh air for comfort and hygiene

In the rooms where we spend most of our time, it is important for our health and well-being to breath fresh and oxygen-rich air.

For this reason, we propose a series of **machines for the latent heat control** combined with the supply of fresh air with heat recovery. Designed specifically for application with radiant heating and cooling, these units are available in various models according to the intended purpose in residential or commercial application. The match between the radiant system and the air handling system ensures correct supply of primary air and thermo-hygrometric control, thus achieving the best temperature and humidity conditions in the room.

The fresh air ventilation takes place with heat recovery in order to limit the use of energy. This means high efficiency and top comfort.

ADVANTAGES OF FRESH AIR SUPPLY WITH DEHUMIDIFICATION:



**AIR RENEWAL AND DEHUMIDIFICATION
COMBINED IN ONE UNIT**



**SUMMER AND WINTER SENSIBLE HEAT
INTEGRATION FUNCTION (ON DEMAND)**



**FREE-COOLING AND FREE HEATING
FUNCTIONS FOR MIDDLE SEASONS**



**CLEAN AIR AND ROOM COMFORT
ALL YEAR ROUND**



WIDE RANGE OF MODELS



ENERGY SAVING



MODEL	CODE
UAP 201-PDC	7040202

Air handling unit for room air exchange with high efficiency heat recovery (~90%) and summer dehumidification, with the possibility of summer and winter integration operating as a heat pump (refrigerant R134a). It uses outdoor air only, and it is designed for horizontal ceiling installation. The unit can be managed either through its control panels or from an external device (via digital input), or via RDZ Wi electronic control unit. It is mandatory to use 2 condensate drain kits (SF-M or SF-P N).

FEATURES

- Dehumidification capacity: (35 °C RH 50% EXT - 26 °C RH 65% INT) with flow rate 200 m³/h: 38.7 l/24h
- Additional sensible cooling capacity up to 770 W, winter 1090 W.

TECHNICAL DATA

- Size l x h x d: 825x244x1118 mm
- Max. electrical power: 590 W
- Elect. power supply 230 Vac - 50 Hz
- Water flow rate (at 15 °C): 240 l/h
- Refrigerant: R134a (250 g)

CONNECTIONS AND FILTERS

- Air duct connections Ø 160 mm
- Hydraulic connections ½" F
- 2 condensate drain Ø 14 mm

- Supply Air
- Fresh Air Inlet
- Stale Air Extraction
- Exhaust Air

ISO ePM₁₀
e(PM10) min ≥ 50%
(Pollen, sand and dust)

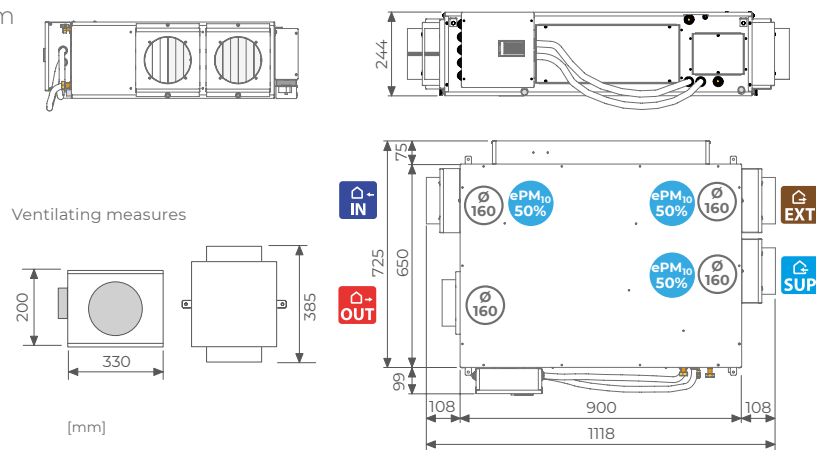

Suggested fan installation

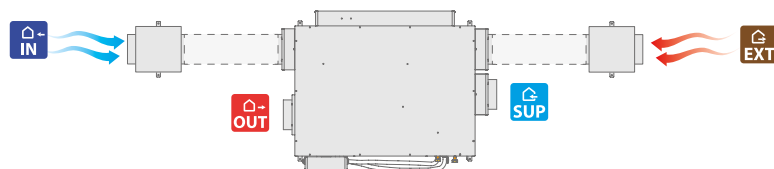



INSTALLATION

- Horizontal ceiling mounted
- Slope 2%

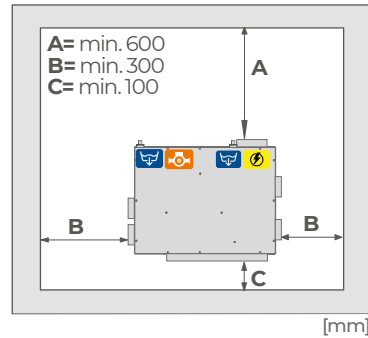
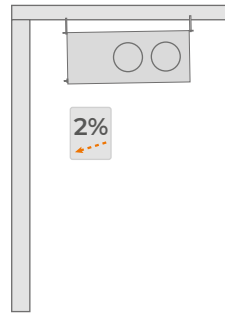
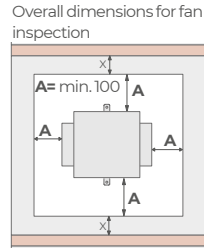

- Hydraulic connections
- Condensate drain
- Wiring Box

PERFORMANCE

m ³ /h	Inlet air		Outlet air		Latent cooling power		Sens. cooling power	Cooling power to be supplied to the unit
	°C	% RH	°C	% RH	W	l/g	W	W
100	33	50	26	35,1	729	25,2	374	560
	35	50	26	36,9	859	29,7		650
150	33	50	26	44,0	855	29,5	561	710
	35	50	26	46,7	1023	35,3		820
200	33	50	26	50,2	913	31,5	748	820
	35	50	26	53,6	1121	38,7		940

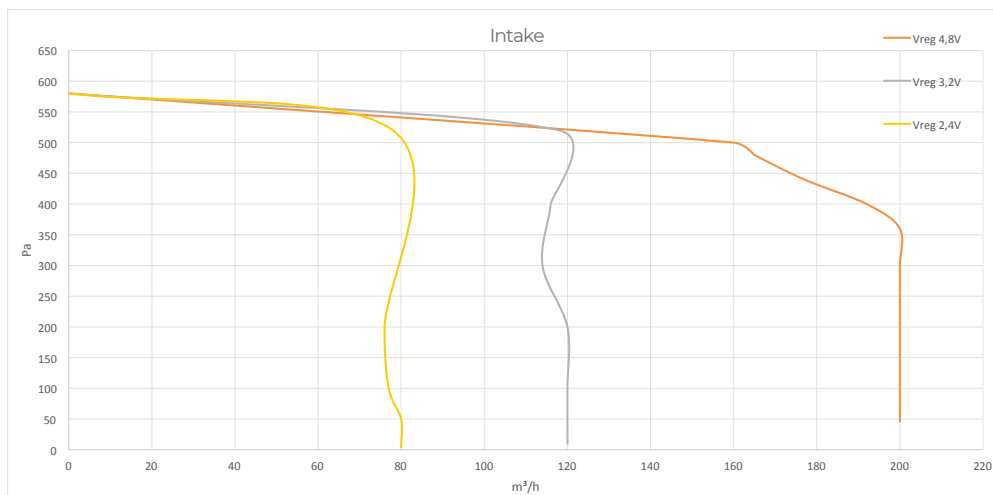

COMPLEMENTS

	Control				Accessories		
Name							
	User Display	TH User Display	Core Air Conv	KNX-UTA Interface	Flow meter	Condensate drain kit	Sifowall
Page	108	108	104	106	111	110	110

UC 300 V2



MODEL	CODE
UC 300 V2	7041308

Air handling unit for room air exchange with high efficiency heat recovery (~90%) and for summer dehumidification. Fresh air intake flow-rate and supply air flow-rate are handled separately (partial recirculation of air is possible). The fresh air flow-rate can be set from 80 to 160 m³/h, while the supply air flow rate can be set from 160 to 300 m³/h. The unit can be managed either through its control panels or from an external device (via digital input), or via RDZ Wi electronic control unit. It is mandatory to use 2 condensate drain kits (SF-M or SF-P N).

FEATURES

- Dehum. capacity (recirculation): 38.7 l/24h at (26 °C RH 65%)
- Dehumidification capacity (renewal) 51.4 l/24h at (35 °C RH 50%)
- Additional sensible cooling capacity: 900 W
- Stainless steel condensate collection tray

TECHNICAL DATA

- Size l x h x d: 773x276x1171 mm
- Max. electrical power: 494 W
- Elect. power supply 230 Vac - 50 Hz
- Nominal water flow capacity (at 15 °C): 410 l/h
- Refrigerant: R290 (95 g)

CONNECTIONS AND FILTERS

- Air duct connections Ø 100 and 160 mm
- Hydraulic connections ½" F
- 2 condensate drain Ø 14 mm

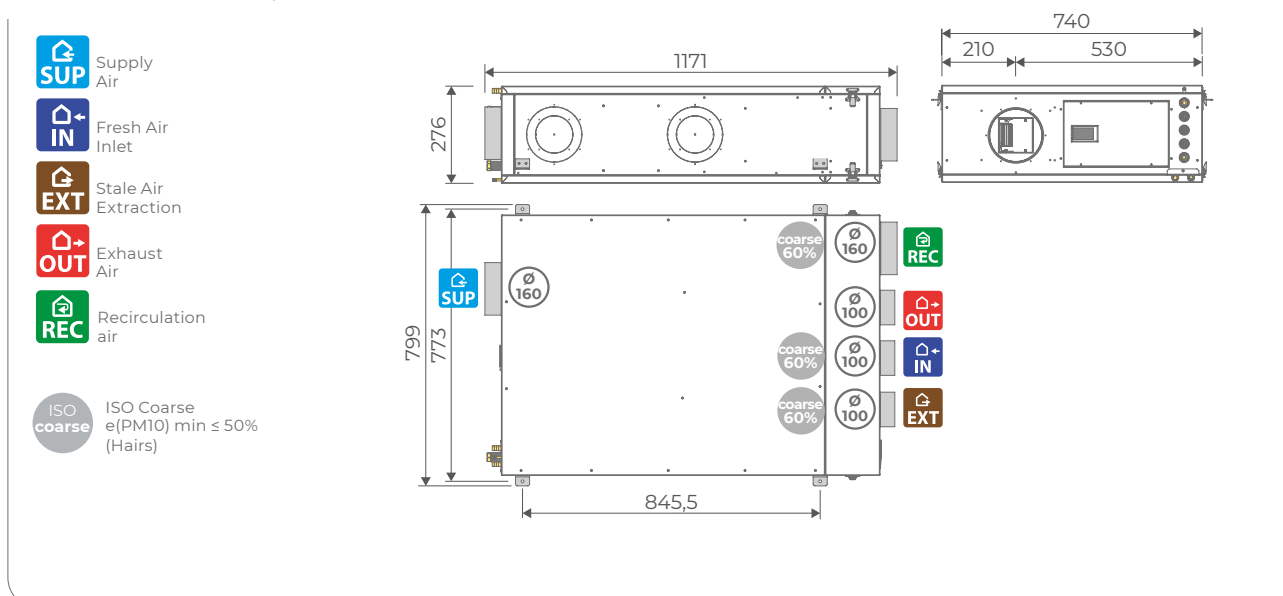



AHU FOR RESIDENTIAL APPLICATION

INSTALLATION

- Horizontal ceiling mounted
- Slope 2%



Unit weight

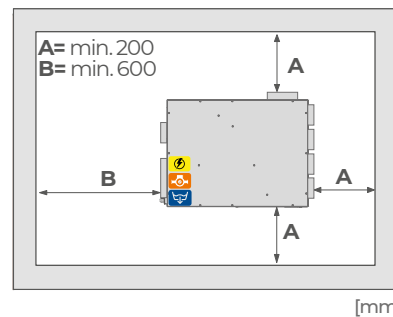
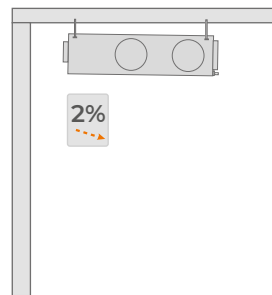

- Hydraulic connections
- Condensate drain
- Wiring Box

PERFORMANCE

Performance in recirculation mode

Inlet air		Outlet air		Latent cooling power		Min. inflow air temp	Sens. cooling power		Cooling power to be supplied to the unit	
°C	% RH	°C	% RH	W	l/g	°C	Max	Set 19 °C	Dehumid.	Integrat.*
W	W	W	W	W	W	W	W	W	W	W
200 m³/h										
26	55	26	40	522	19,9	12,3	960	490	945	1765
26	65	26	41	795	30,2	13,2	896	490	1215	1985
300 m³/h										
26	55	26	44	522	19,9	14,9	1165	735	925	2040
26	65	26	48	841	32	15,4	1113	735	1280	2300

Performance in recirculation mode + renewal mode

Recirculation air			Renewal air			Neutral outlet air		Latent cooling power		Min. inflow air temp	Sens. cooling power		Cooling power to be supplied to the unit	
°C	% RH	m³/h	°C	% RH	m³/h	°C	% RH	W	l/g	°C	Max	Set 19 °C	Dehumid.	Integrat.*
W	W	W	W	W	W	W	W	W	W	W	W	W	W	W
200 m³/h														
26,0	55	120	35	50	80	26	42	885	33,7	13,8	854	490	1350	2075
26,0	65	120	35	50	80	26	46	1000	38	14,9	777	490	1513	2230
26,0	55	40	35	50	160	26	45	1090	41,5	14,3	819	490	1675	2335
26,0	65	40	35	50	160	26	45	1135	43,2	14,9	777	490	1695	2385
300 m³/h														
26,0	55	220	35	50	80	26	48	818	31,1	15,3	1124	735	1315	2300
26,0	65	220	35	50	80	26	49	978	37,2	16	1050	735	1500	2430
26,0	55	140	35	50	160	26	51	978	37,2	15,6	1092	735	1500	2470
26,0	65	140	35	50	160	26	53	1181	44,9	16,5	998	735	1740	2630

*The power to give to the integration unit has to be intended as the necessary power on the default set-point, for different value the power has to be verified

PERFORMANCE

Renewal performance**

Inlet air		Outlet air		Latent cooling power		Min. inflow air temp	Sens. cooling power		Cooling power to be supplied to the unit	
°C	% RH	°C	% RH	W	l/g		Max	Set 19 °C	Dehumid.	Integrat.*
30	50	26	40	705	26,8	11,8	1491	392	1150	1790
33	50	26	41	931	35,4	12,8	1386	392	1460	2040
35	50	26	48	1136	43,2	13,3	1334	392	1695	2270

*The power to give to the integration unit has to be intended as the necessary power on the default set-point, for different value the power has to be verified

** Renewal function is allowed only if the intake fan and the expulsion fan are working with the same flow rate of 160 m³/h, to calculate the air temperature after the heat recovery unit is supposed a room temperature of 26°C.

Supply air fan

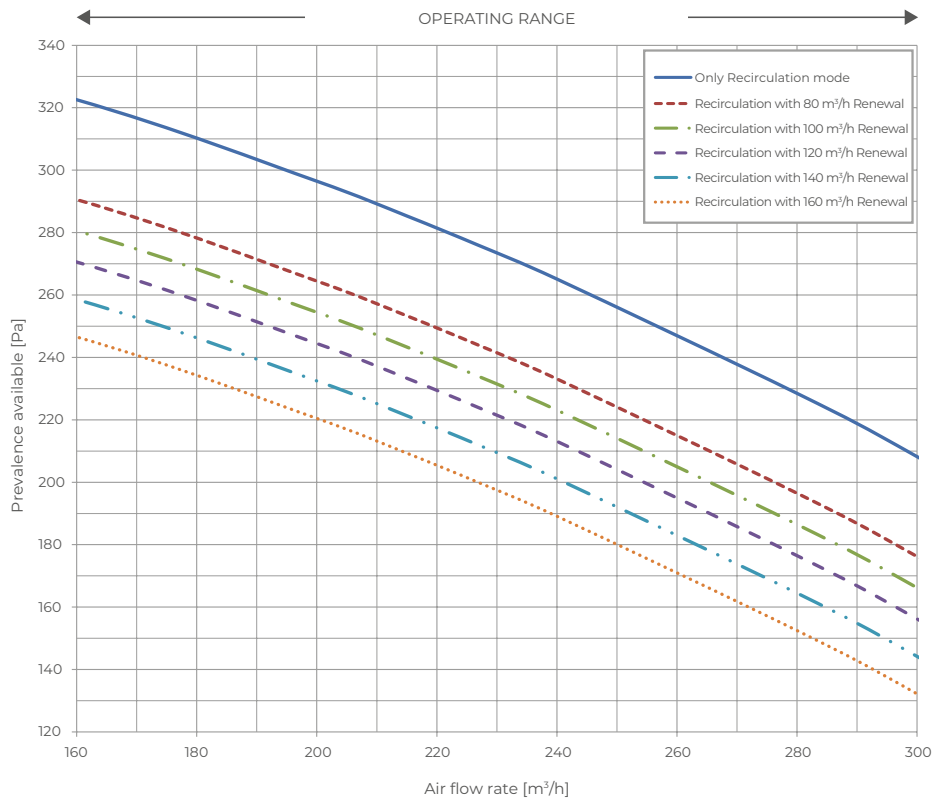

COMPLEMENTS

	Control				Accessories			Optional
Name	User Display	TH User Display	Core Air Conv	KNX-UTA Interface	MP 2-12 Flow meter	SF-M 13 Condensate drain kit	SF-P N Sifowall	Damper
Page	108	108	104	106	111	110	110	



MODEL	CODE
UC 360 V1	7041359

Air handling unit for room air exchange with high efficiency heat recovery (~90%) and for summer dehumidification. Fresh air intake flow-rate and supply air flow-rate are handled separately (partial recirculation of air is possible). The fresh air flow-rate can be set from 100 to 240 m³/h, while the supply air flow rate can be set from 200 to 360 m³/h). Possible operations include fresh air ventilation, air recirculation, freecooling, boost, dehumidification as well as integration of summer and winter sensible capacity. The unit can be managed either through its control panels or from an external device (via digital input), or via RDZ Wi electronic control unit. Dehumidification capacity (recirculation) 40.2 l/24h (26 °C RH 65%). It is mandatory to use 2 condensate drain kits (SF-M or SF-P N).

FEATURES

- Dehum. capacity (recirculation): 40.2 l/24h (26 °C RH 65%)
- Additional sensible cooling capacity: 1400 W
- Air connections Ø 160 mm (excluding stale air extract ducting Ø 125 mm).
- Stainless steel condensate collection tray
- Finned heat exchangers with hydr. treatment

TECHNICAL DATA

- Size l x h x d: 903x276x1282 mm
- Max. electrical power: 940 W
- Elect. power supply 230 Vac - 50 Hz
- Nominal water flow capacity (at 15 °C) 360 l/h
- Refrigerant: R290 (95 g)

CONNECTIONS AND FILTERS

- Air duct connections Ø 125 e 160 mm
- Hydraulic connections ½" F
- 2 condensate drain Ø 20 mm

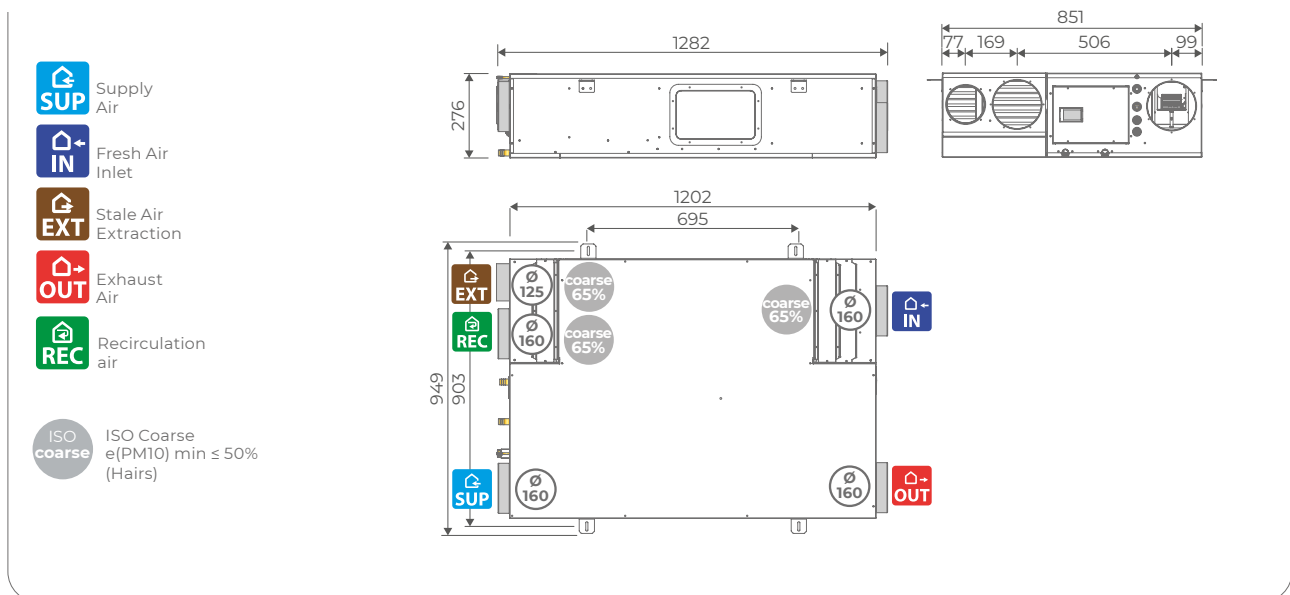



INSTALLATION

- Horizontal ceiling mounted
- Slope 2%

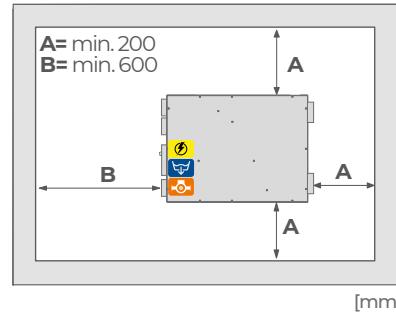
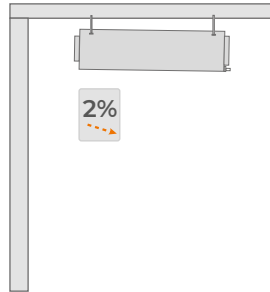

- Hydraulic connections
- Condensate drain
- Wiring Box

PERFORMANCE

Performance in recirculation mode

Inlet air		Outlet air		Latent cooling power		Sens. cooling power		Cooling power to be supplied to the unit
°C	% RH	°C	% RH	W	l/g	Max	Set 19 °C	
200 m³/h								
26	55	26	34,8	732	25,3	987	476	740
26	65	26	36,5	1042	36	937	476	970
280 m³/h								
26	55	26	40,2	753	26	1234	667	930
26	65	26	42,9	1134	39,2	1141	667	1180
360 m³/h								
26	55	26	44	724	25	1463	857	1080
26	65	26	47,4	1163	40,2	1324	857	1330

Performance in renewal mode



Inlet air		Outlet air		Latent cooling power		Sens. cooling power		Cooling power to be supplied to the unit
°C	% RH	°C	% RH	W	l/g	Max	Set 19 °C	
200 m³/h								
33	50	26	38,5	1339	46,3	884	476	1240
35	50	26	40,4	1596	55,1	835	476	1440
240 m³/h								
33	50	26	42,5	1434	49,5	969	619	1390
35	50	26	44,8	1727	59,6	903	619	1610

AHU FOR RESIDENTIAL APPLICATION

Performance in recirculation mode + renewal mode

Supply air	Renewal air		Recirculation air			Neutral outlet air		Latent cooling power		Sens. cooling power		Cooling power to be supplied to the unit									
	m³/h	°C	% RH	m³/h	°C	% RH	m³/h	°C	% RH	W	l/g		W	W							
200	33	50	100	26	55	100	26	36,4	1009	34,9	941	476	960								
													65	37,3	1169	40,4	916	1070			
													35	55	37,2	1144	39,5	920	1060		
																			65	38,2	1306
													33	55	37,6	1192	41,2	909	1110		
																			65	37,9	1260
	35	65	38,9	1411	48,7	873	1270														
							65	39,3	1458	50,3	863		1310								
	280	33	50	100	26	55	180	26	42,0	991	34,2		1173	667	1100						
															65	43,7	1228	42,4	1116	1260	
															35	55	42,8	1097	37,9	1146	1180
																					65
33												55			43,2	1155	39,9	1132	1230		
																			65	44,3	1303
35		65	44,5	1347	46,5	1088	1370														
							65	45,7	1486	51,3	1050	1480									
33		50	160	26	55	120	26	44,0	1259	43,5	1106	1066	1330								
													65		44,8	1373	47,4	1080	1400		
													35		55	45,4	1437	49,6	1058	1470	
																				65	46,6
													33		55	44,9	1353	46,7	1075	1420	
																				65	45,2
35		65	47,0	1625	56,1	1008	1620														
							65	47,5	1684	58,1	993	1660									
360		33	50	100	26	55	260	26	45,7	920	31,8	1392	857		1100						
															65	48,1	1245	43,0	1298	1260	
															35	55	46,4	1014	35,0	1365	1180
																					65
															33	55	46,8	1068	36,9	1347	1230
																					65
		35	65	48,2	1226	42,3	1294	1370													
								65	50,1	1476	51,0	1220			1480						
	33	50	160	26	55	200	26	47,6	1161	40,1	1315	1258		1330							
														65	49,1	1369	47,3	1258	1400		
														35	55	49,4	1376	47,5	1247	1470	
																				65	50,9
														33	55	48,5	1261	43,6	1282	1420	
																				65	49,5
	35	65	50,5	1492	51,5	1205	1620														
							65	51,7	1637	56,5	1158	1660									

COMPLEMENTS

	Control				Accessories		
							
Name	User Display	TH User Display	Core Air Conv	KNX-UTA Interface	MP 2-12 Flow meter	SF-M 20 Condensate drain kit	SF-P N Sifowall
Page	108	108	104	106	111	110	110



MODEL	CODE
UC 501-MHE	7041456

Air handling unit with high-efficiency heat recovery for ventilation and summer dehumidification. The high-efficiency counter-current heat exchanger (~90%) is situated in the exhaust air duct. Air outlets (in- and outward ducts) on the two shorter opposite sides, which means that the ductwork can be connected easily, and it can be installed in narrow spaces. Operations: fresh air ventilation, air recirculation, free cooling, booster, dehumidification, integration of summer and winter sensible capacity (external input). Condensed by air. Free additional sensible cooling without using cool water from the chiller. It is mandatory to use 3 condensate drain kits (SF-M or SF-P N).

FEATURES







- Dehumidification capacity (recirculation): 31.2 l/24h at (26 °C RH 55%)
- Dehumidification capacity (renewal): 74.1 l/24h at (35 °C RH 50%)
- Additional sensible cooling capacity: 1870 W
- Stainless steel condensate collection tray
- Finned heat exchangers with hydrophilic treatment

TECHNICAL DATA

- Size l x h x d: 1287x424x961 mm
- Max. electrical power: 1100 W
- Elect. power supply 230 Vac - 50 Hz
- Nominal water flow capacity (at 15 °C): 500 l/h

CONNECTIONS AND FILTERS

- Air duct connections Ø 150 - 200 mm
- Hydraulic connections ½" F
- 3 condensate drain Ø 14 mm

-  Supply Air
-  Fresh Air Inlet
-  Stale Air Extraction
-  Exhaust Air
-  Recirculation air
-  ISO Coarse e(PM10) min ≤ 50% (Hairs)

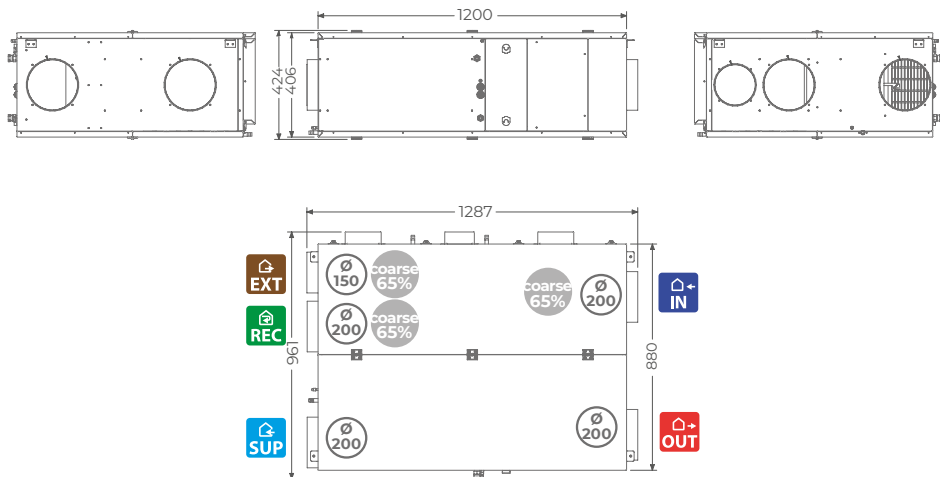



INSTALLATION

- Horizontal ceiling mounted
- Slope 2%



Unit weight

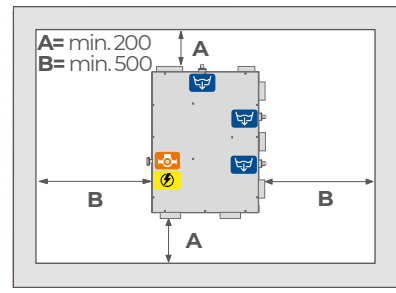
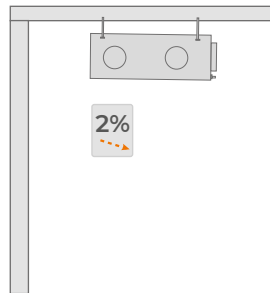

- Hydraulic connections
- Condensate drain
- Wiring Box

[mm]

PERFORMANCE

Renewal air			Recirculation air			Neutral outlet air		Latent cooling power		Sens. cooling power	Cooling power to be supplied to the unit
°C	% RH	m³/h	°C	% RH	m³/h	°C	% RH	W	l/g	Max	
200 m³/h											
35	50	0	26	65	200	26	36,0	1753	60,6	1230	947
300 m³/h											
35	50	160	26	65	140	26	36,4	2138	73,9	1750	1855
		250			50		37,3	2379	82,2	1770	2092
		300			0		40,6	2514	86,8	1790	2237
400 m³/h											
35	50	0	26	65	400	26	40,1	1841	63,6	2015	1734
		160			240		42,0	2244	77,5	1980	2072
		300			100		44,4	2592	89,5	2010	2405
500 m³/h											
35	50	0	26	65	500	26	44,4	1915	66,2	2240	1951
		160			340		46,3	2292	79,2	2200	2247
		300			200		48,6	2600	89,8	2210	2535

COMPLEMENTS

	Control			Accessories		
Name	Remote control type 1 code for UC 501-MHE	Core Air Conv	KNX-UTA Interface	MP 2-12 Flow meter	SF-M 13 Condensate drain kit	SF-P N Sifowall
Page	109	104	106	111	110	110



MODEL	CODE
UC 500-MVHE	7041451

Vertical unit for fresh air ventilation with high efficiency heat recovery (~90%) and for summer dehumidification. The flow rate of inlet fresh air and supply air can be managed independently, allowing the unit to work with partial air recirculation (fresh air supply flow rate 100÷400 m³/h - supply air flow rate 300÷500 m³/h). Functionality of air renewal, air recirculation, free-cooling, boost, dehumidification and sensible power integration for heating and cooling. Unit can be either managed through the remote control panel Type 1 or Wi controller. It is mandatory to use 2 condensate drain kit.

FEATURES

- Dehumidification capacity: (recirculation 500 m³/h) 61.9 l/24h at (26 °C RH 55%)
- Dehumidification capacity: (renewal) 95.1 l/24h at (35 °C RH 50%)
- Additional sensible cooling capacity: 1925 W
- Stainless steel condensate collection tray
- Finned heat exchangers with hydrophilic treatment

TECHNICAL DATA

- Size l x h x d: 900x1465x570 mm
- Max. electrical power: 800 W
- Elect. power supply 230 Vac - 50 Hz
- Water flow capacity (at 15 °C): 500 l/h
- Refrigerant: R410a (770g)

CONNECTIONS AND FILTERS

- Air duct connections Ø 200 mm
- Hydraulic connections ½" F
- Condensate drain Ø 20 mm

- Supply Air
- Fresh Air Inlet
- Stale Air Extraction
- Exhaust Air
- Recirculation air
- ISO Coarse e(PM10) min ≤ 50% (Hairs)

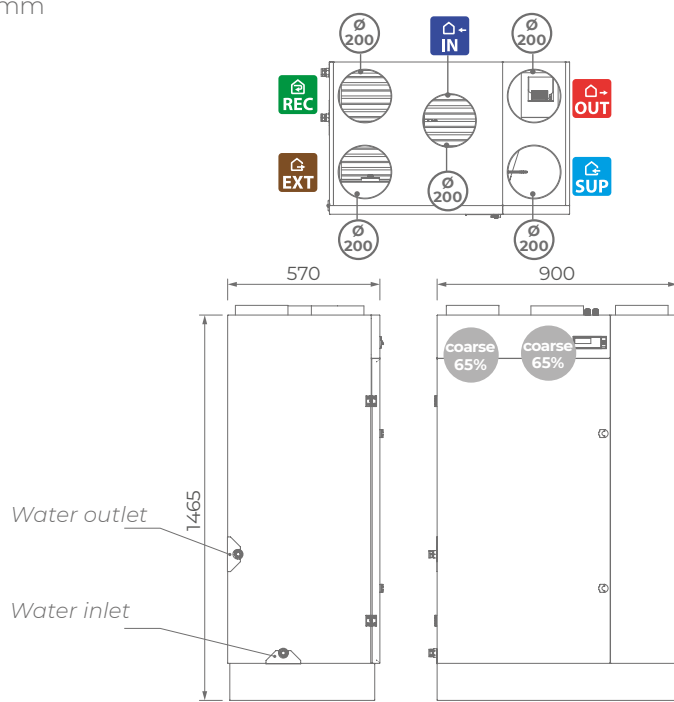

[mm]



INSTALLATION

- Verticale a pavimento



Unit weight

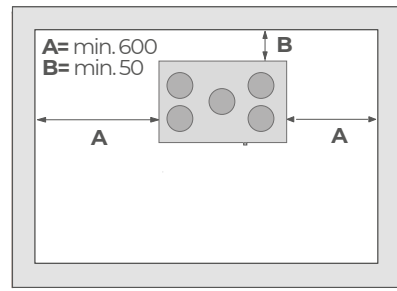
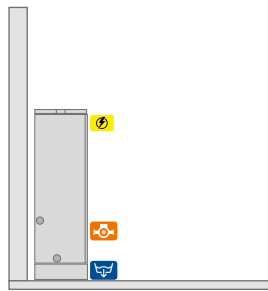

[mm]

- Hydraulic connections
- Condensate drain
- Wiring Box

PERFORMANCE

Performance in recirculation mode

Inlet air		Outlet air		Latent cooling power		Sens. cooling power		Cooling power to be supplied to the unit
°C	% RH	°C	% RH	W	l/g	Max	Set 19 °C	
300 m³/h								
26	55	26	34,9	1097	37,9	1155	735	1180
26	65	26	36,3	1576	54,4	1155	735	1560
400 m³/h								
26	55	26	39,4	1122	38,8	1540	980	1450
26	65	26	41,6	1697	58,6	1540	980	1870
500 m³/h								
26	55	26	42,7	1127	38,9	1925	1225	1670
26	65	26	45,5	1791	61,9	1925	1225	2120

Performance in renewal mode







Inlet air		Outlet air		Latent cooling power		Sens. cooling power		Cooling power to be supplied to the unit
°C	% RH	°C	% RH	W	l/g	Max	Set 19 °C	
300 m³/h								
33	50	26	38,0	2040	70,5	1155	735	2010
35	50	26	39,6	2448	84,5	1155	735	2340
400 m³/h								
33	50	26	44,1	2281	78,8	1540	980	2400
35	50	26	46,4	2754	95,1	1540	980	2780

PERFORMANCE

Performance in recirculation mode + renewal mode

Supply air	Renewal air		Recirculation air			Neutral outlet air		Latent cooling power		Sens. cooling power		Cooling power to be supplied to the unit				
	m³/h	°C	% RH	m³/h	°C	% RH	m³/h	°C	% RH	W	l/g		W	W		
300	33	50	100	26	26	55	26	35,7	1358	46,9	1155	735	1410			
						65		200	36,7	1684	58,2	1155	735	1660		
						55		100	36,1	1516	52,3	1155	735	1520		
						65			37,2	1827	63,1	1155	735	1780		
						55			36,7	1679	58,0	1155	735	1690		
						65			40,0	1845	63,7	1155	735	1820		
	35	200	55	37,7	1966	67,9	1155	735	1910							
			65	38,3	2117	73,1	1155	735	2030							
	400	33	50	100	26	26	55	26	40,3	1358	46,9	1540	980	1620		
							65		300	42,0	1806	62,4	1540	980	1950	
							55		200	40,8	1504	51,9	1540	980	1720	
							65			42,5	1926	66,5	1540	980	2040	
55							41,5			1660	57,3	1540	980	1870		
65							42,6			1948	67,3	1540	980	2080		
35		200	55	42,4	1914	66,1	1540	980	2060							
			65	43,6	2209	76,3	1540	980	2260							
33		50	300	26	26	26	55	26	42,7	1943	67,1	1540	980	2120		
							65		100	43,2	2077	71,7	1540	980	2220	
							55		100	44,2	2305	79,6	1540	980	2400	
							65			44,8	2459	84,9	1540	980	2500	
	55						43,6			1326	45,8	1925	1225	1810		
	65						400			45,8	1850	63,9	1925	1225	2170	
35	200	55	44,1	1438	49,6	1925	1225	1890								
		65	46,3	1969	68,0	1925	1225	2250								
500	33	50	100	26	26	55	26	44,8	1586	54,8	1925	1225	2010			
						65		300	46,5	2003	69,2	1925	1225	2280		
						55		200	45,7	1810	62,5	1925	1225	2180		
						65			47,5	2206	76,2	1925	1225	2450		
						55			45,9	1848	63,8	1925	1225	2230		
						65			47,1	2111	72,9	1925	1225	2410		
	35	200	55	47,5	2188	75,6	1925	1225	2480							
			65	48,4	2473	85,4	1925	1225	2650							
	33	50	300	26	26	26	55	26	47,1	2106	72,7	1925	1225	2460		
							65		100	47,8	2244	77,5	1925	1225	2540	
							55		49,3	2550	88,0	1925	1225	2780		
							65		49,9	2705	93,4	1925	1225	2870		
35							400		55	100	47,8	2244	77,5	1925	1225	2540
									65		49,3	2550	88,0	1925	1225	2780

COMPLEMENTS

	Control			Accessories		
						
Name	Remote control type 1 code for UC 500-MVHE	Core Air Conv	Interface KNX-UTA	MP 2-12 Flow meter	SF-M 20 Condensate drain kit	SF-P N Sifowall
Page	109	104	106	111	110	110

Selection guide

Air renewal with dehumidification

The residential ventilation standard (EN 16798) identifies:

3 categories of air exchange according to the flow of fresh air considered for each occupant.

category	fresh air flow rate	
	in l/sec per person	in m ³ /h per person
I	10	~ 36
II	7	~ 25
II	4	~ 15

2 levels of acceptability of specific humidity.

level	specific air humidity g/kg _{d.a.}	corresponding value
I	12	26 °C - 57 % R.H.
II	13	26 °C - 62 % R.H.

RDZ defined a matrix identifying 6 comfort levels based on the required degree of ventilation and dehumidification

comfort level	fresh air flow rate L/sec per person	specific humidity of the room air in g/kg _{d.a.}
A - excellent	10	12 (26 °C - 57 %)
B- extremely good	10	13 (26 °C - 62 %)
C - very good	7	12 (26 °C - 57 %)
D - good	7	13 (26 °C - 62 %)
E - fair	4	12 (26 °C - 57 %)
F - Adequate	4	13 (26 °C - 62 %)

Our experience leads us to suggest considering a humidity value of 12 g/kg_{d.a.} as a reference value.

AHU selection chart

max occupants	Indoor comfort level depending on the air exchange and humidity value according to (EN 16798)						
	A excellent		C very good		E Adequate		
	renewal only	renewal + recirculation	renewal only	renewal + recirculation	renewal only	renewal + recirculation	
4	UAP 201-PDC	UC 300 V2	UAP 201-PDC	UC 300 V2	UAP 201-PDC	UC 300 V2	
5	MVHR+DWF 200	UC 360 V1					
6	MVHR + DWF 400	UC 501-MHE	MVHR + DWF 200	UC 360 V1	MVHR + DWF 200	UC 360 V1	
7							
8		UC 500-MVHE	MVHR + DWF 400	UC 501-MHE	UC 500-MVHE	MVHR + DWF 400	UC 500-MVHE
9							
10							
11							
12	UC 501-MHE	UC 501-MHE	UC 501-MHE	UC 501-MHE	UC 501-MHE	UC 501-MHE	
13							
14							
15							
16							
17							
18							
19							

AHU comparison chart

type	RDZ model	nominal ventilation rate	max recirculation flow rate	total supply flow rate	available pressure	max. summer integration	maximum number of people per comfort level		
		m ³ /h	m ³ /h	m ³ /h	Pa	W	A excellent	C very good	E Adequate
dehumidifiers (without fans)	MVHR + DWF 200	200	-	200	200	-	5	8	11
	MVHR + DWF 400	400	-	400	200	-	11	14	18
AHU using outdoor air only (4 ducts) ceiling mounted	UAP 201-PDC	200	-	200	200	750	4	5	6
AHU with recirculation+ ventilation (5 ducts) ceiling mounted	UC 300 V2	140	0-300	300	200	1155	4	6	8
	UC 360 V1	240	0-360	360	200	1386	6	8	9
	UC 501-MHE	300	0-500	500	200	1925	8	12	19
AHU with recirculation+ ventilation (5 ducts) floor standing	UC 500-MVHE	400	0-500	500	200	1925	11	12	15



MODEL	CODE
DA 701	7041701
SR 701	7041711

Air handling unit designed for horizontal ceiling installation, combining the DA 701 dehumidifier and the SR 701 heat recovery unit. Possible operations: air recirculation, fresh air ventilation (100% outdoor air), summer dehumidification, additional sensible heating and cooling capacity. Modulating valve is compulsory. It is mandatory to use 2 condensate drain kits (SF-M or SF-P N).

FEATURES

- Dehumidification capacity (recirculation): 93.2 l/24h at (26 °C RH 65%)
- Dehumidification capacity (renewal): 163.1 l/24h at (35 °C RH 50%)
- Additional sensible cooling capacity: 2295 W
- Stainless steel condensate collection tray
- Finned heat exchangers with hydrophilic treatment

TECHNICAL DATA

- Size l x h x d: 1000x388x1517 mm
- Max. electrical power: 1230 W DA + 300 W SR
- Elect. power supply 230 Vac - 50 Hz
- Pre-treatment water flow rate at 15 °C: 750 l/h
- Condensation water flow rate at 15 °C: 110 l/h
- Refrigerator: R410a (1060 g)

CONNECTIONS AND FILTERS

- Air duct connections EXT+REC: 616x327 mm; SUP: 231x207 mm; IN: 400x327 mm; OUT: 231x207 mm
- Hydraulic connections: Pre-treatment 3/4" F and condensation 1/2" F
- Condensate drain DA Ø 20 mm - SR Ø 14 mm

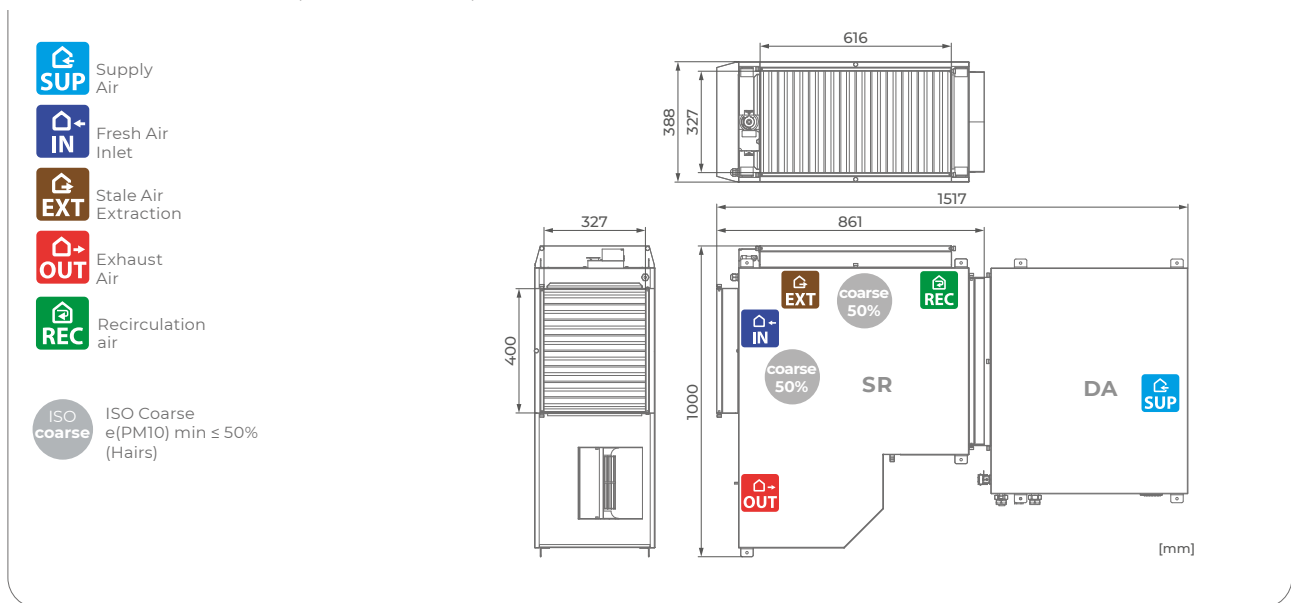



AHU FOR COMMERCIAL APPLICATION

INSTALLATION

- Horizontal ceiling mounted
- Slope 2%

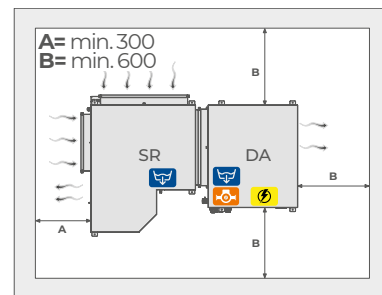
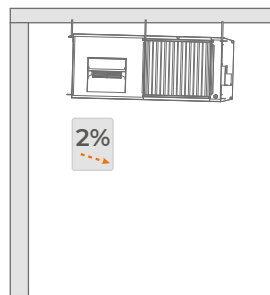

- Hydraulic connections
- Condensate drain
- Wiring Box

[mm]

PERFORMANCE

DA 701 + SR 701 - Performance in dehumidification mode (Summer)

Inlet air		Outlet air		Latent cooling power		Min. inflow air temp	Sens. cooling power		Cooling power to be supplied to the unit		
°C	% RH	°C	% RH	W	l/g		°C	Max	Set 17 °C	Dehumid.	Integrat.*
700 m³/h											
33	50	26	47.4	3652	126.1	15.2	2568	2142	4275	6843	
35	50	26	50.2	4531	156.5	16.1	2354	2142	5151	7505	
750 m³/h											
33	50	26	48.4	3791	130.9	15,5	2691	2295	4412	7104	
35	50	26	51.2	4724	163.1	16,3	2467	2295	5342	7809	

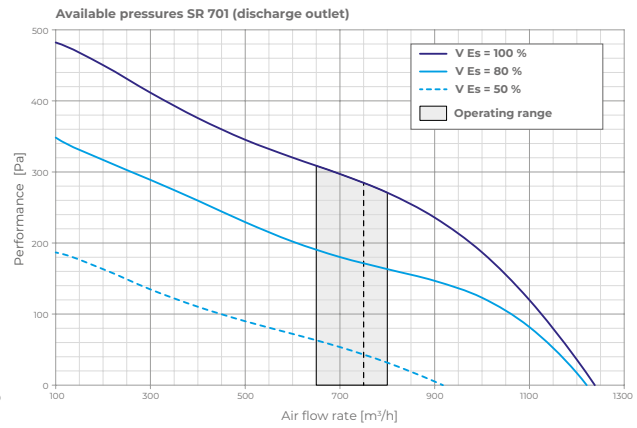
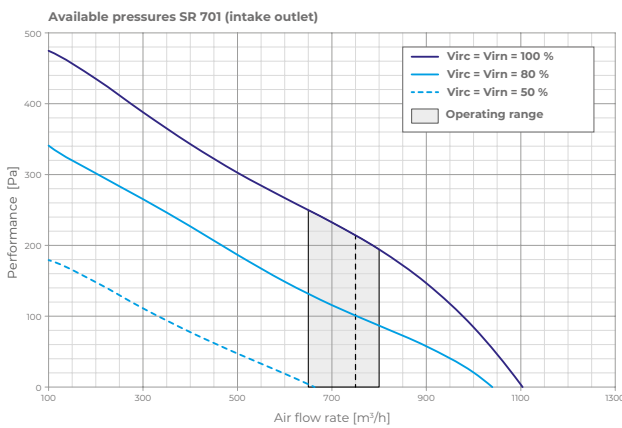

COMPLEMENTS

	Accessories					
Name	Core Air Conv	MP 5-42 Flow meter	Modulating valve Ø 3/4"	SF-M 20 Condensate drain kit	SF-M 13 Condensate drain kit	SF-P N Sifowall
Page	104	111	112	110	110	110



MODEL	CODE
DA 1001	7041101
SR 1001	7041111

Air handling unit for horizontal ceiling installation, combining the DA 1001 dehumidifier and the SR 1001 heat recovery unit. Possible operations: air recirculation, fresh air ventilation (100% outdoor air), summer dehumidification, additional sensible heating and cooling capacity. Modulating valve is compulsory. It is mandatory to use 2 condensate drain kits (SF-M or SF-P N).

FEATURES

- Dehumidification capacity (recirculation): 127.5 l/24h at (26 °C HR 65%)
- Dehumidification capacity (renewal): 216 l/24h at (35 °C HR 50%)
- Additional sensible cooling capacity: 3150 W
- Stainless steel condensate collection tray
- Finned heat exchangers with hydrophilic treatment

TECHNICAL DATA

- Size l x h x d: 1101 x 388 x 1645 mm
- Max. electrical power: 2040 W DA + 500 W SR
- Elect. power supply 230 Vac - 50 Hz
- Pre-treatment water flow rate at 15 °C: 1000 l/h
- Condensation water flow rate at 15 °C: 130 l/h
- Refrigerator: R410a (1250 g)

CONNECTIONS AND FILTERS

- Air duct connections EXT+REC: 661x327 mm; SUP: 231x207 mm; IN: 498x327 mm; OUT: 231x207 mm
- Hydraulic connections: Pre-treatment 3/4" F and condensation 1/2" F
- Condensate drain DA Ø 20 mm - SR Ø 14 mm

- Supply Air
- Fresh Air Inlet
- Stale Air Extraction
- Exhaust Air
- Recirculation air
- ISO Coarse e(PM10) min ≤ 50% (Hairs)

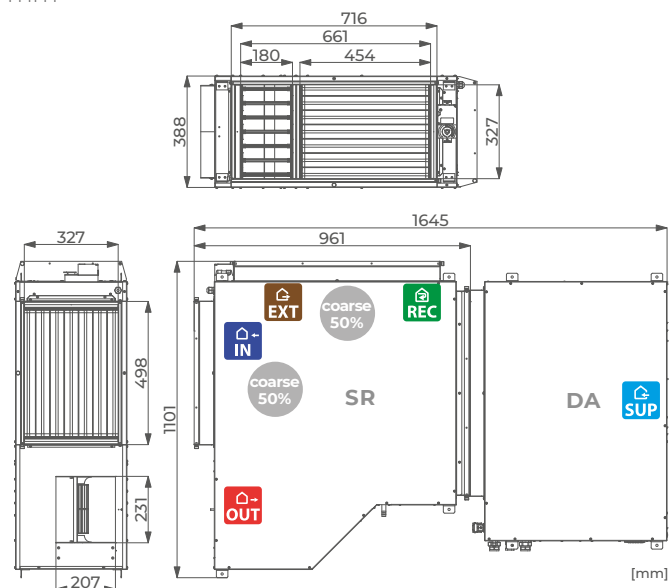



INSTALLATION

- Horizontal ceiling mounted
- Slope 2%

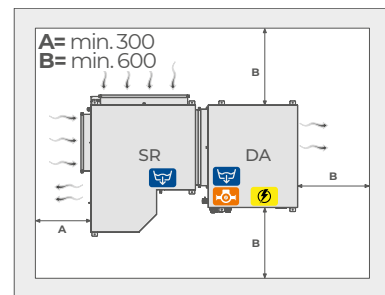
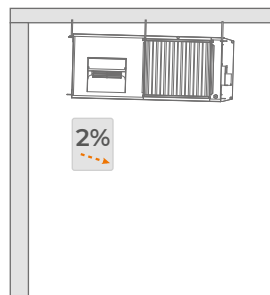

- Hydraulic connections
- Condensate drain
- Wiring Box

[mm]

PERFORMANCE

DA 1001 + SR 1001 - Performance in dehumidification mode (Summer)

Inlet air		Outlet air		Latent cooling power		Min. inflow air temp	Sens. cooling power		Cooling power to be supplied to the unit		
°C	% RH	°C	% RH	W	l/g		°C	Max	Set 17 °C	Dehumid.	Integrat.*
Recirculation											
26	55	26	42.5	2262	78.1	14.6	3994	3150	4122	8116	
26	65	26	44.8	3692	127.5	15.4	3714	3150	5552	9266	
Renewal											
33	50	26	47.9	5041	174	16.4	3353	3150	8156	11509	
35	55	26	50.4	6267	216	17.2	3076	3150	9663	12739	

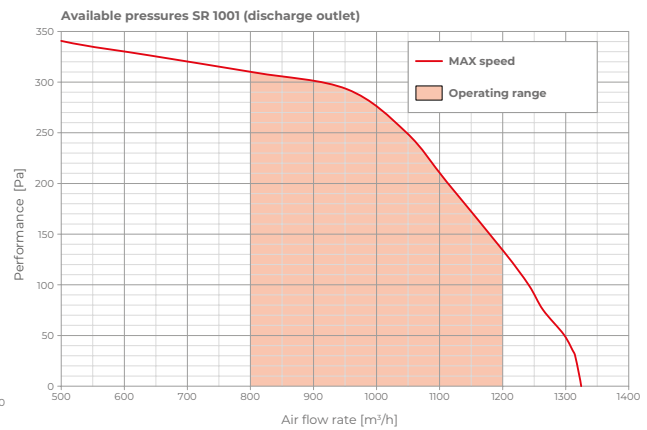
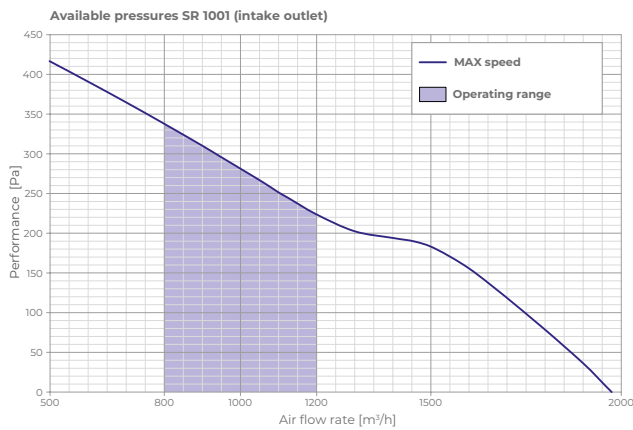

COMPLEMENTS

	Accessories					
Name	Core Air Conv	MP 5-42 Flow meter	Modulating valve Ø 3/4"	SF-M 20 Condensate drain kit	SF-M 13 Condensate drain kit	SF-P N Sifowall
Page	104	111	112	110	110	110



MODEL	CODE
DA 2001	7041501
SR 2001	7041511

Air handling unit for horizontal ceiling installation, combining the DA 2001 dehumidifier and the SR 2001 heat recovery unit. Possible operations: air recirculation, fresh air ventilation (100% outdoor air), summer dehumidification, additional sensible heating and cooling capacity. Modulating valve is compulsory. It is mandatory to use 2 condensate drain kits (SF-M or SF-P N).

FEATURES

- Dehumidification capacity (recirculation): 242.8 l/24h at (26 °C HR 65%)
- Dehumidification capacity (renewal): 410.6 l/24h at (35 °C HR 50%)
- Additional sensible cooling capacity: 6300 W
- Stainless steel condensate collection tray
- Finned heat exchangers with hydrophilic treatment

TECHNICAL DATA

- Size l x h x d: 1250x534x1905 mm
- Max. electrical power: 3070 W DA + 500 W SR
- Elect. power supply 230 Vac - 50 Hz
- Pre-treatment water flow rate at 15 °C: 2000 l/h
- Condensation water flow rate at 15 °C: 250 l/h
- Refrigerator: R410a (2500 g)

CONNECTIONS AND FILTERS

- Air duct connections EXT+REC: 845x470 mm; SUP: 231x207 mm; IN: 602x470 mm; OUT: 231x207 mm
- Hydraulic connections: Pre-treatment 1" F and condensation 1/2" F
- Condensate drain DA Ø 20 mm - SR Ø 14 mm

- Supply Air
- Fresh Air Inlet
- Stale Air Extraction
- Exhaust Air
- Recirculation air
- ISO Coarse e(PM10) min ≤ 50% (Hairs)

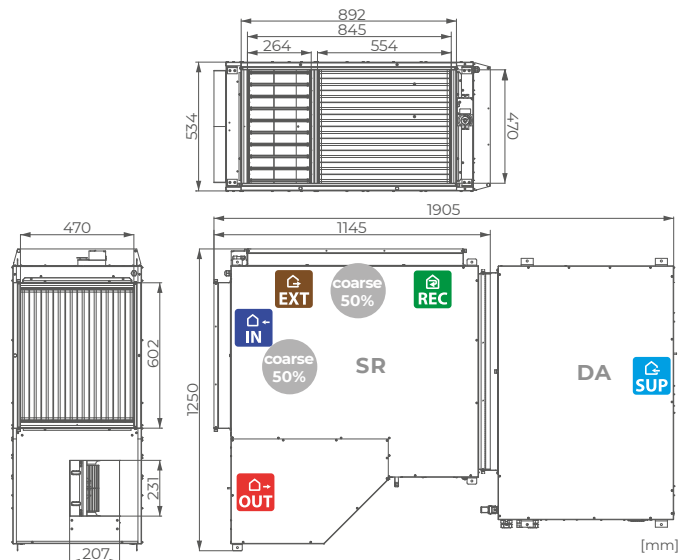



INSTALLATION

- Horizontal ceiling mounted
- Slope 2%

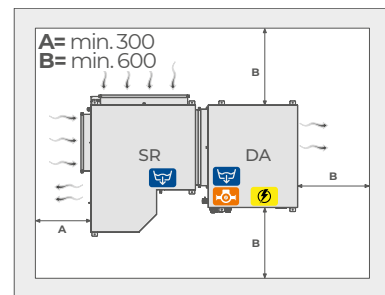
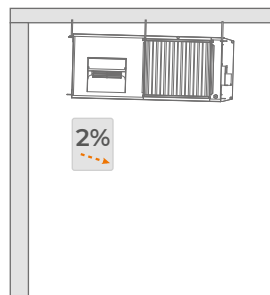

- Hydraulic connections
- Condensate drain
- Wiring Box

[mm]

PERFORMANCE

DA 2001 + SR 2001 - Performance in dehumidification mode (Summer)

Inlet air		Outlet air		Latent cooling power		Min. inflow air temp	Sens. cooling power		Cooling power to be supplied to the unit	
°C	% RH	°C	% RH	W	l/g		Max	Set 17 °C	Dehumid.	Integrat.*
Recirculation										
26	55	26	43.2	4300	148.5	13.9	8456	6300	7430	15886
26	65	26	45.8	7031	242.8	14.8	7812	6300	10161	17974
Renewal										
33	50	26	49.3	9617	332.1	16	7021	6300	14777	21798
35	55	26	52.2	11890	410.6	16.8	6412	6300	17610	24022

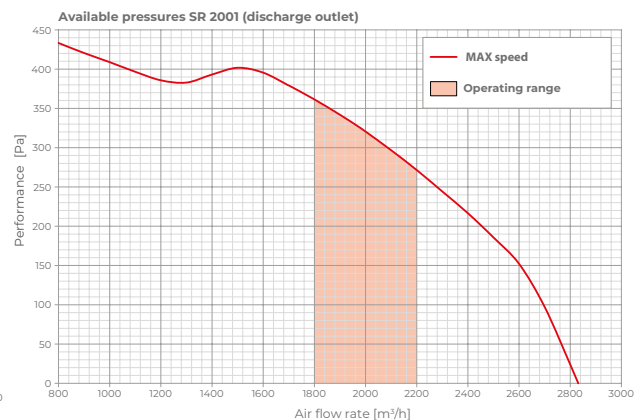
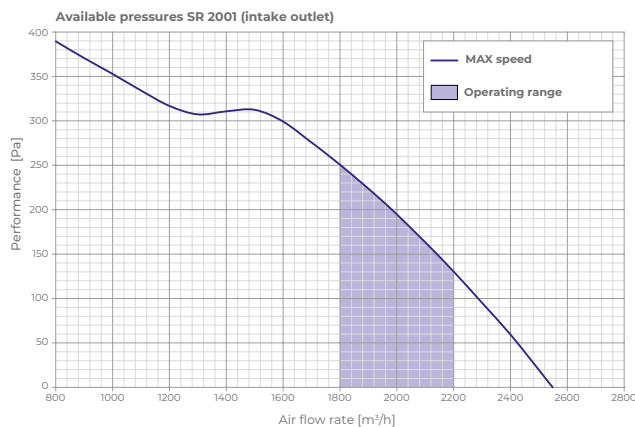

COMPLEMENTS

	Accessories					
Name	Core Air Conv	MP 20-70 Flow meter	Modulating valve Ø 3/4"	SF-M 20 Condensate drain kit	SF-M 13 Condensate drain kit	SF-P N Sifowall
Page	104	111	112	110	110	110

**Air
Handling**

















COMPLEMENTS



Summary table of control systems

Control panels for our air handling units allow you to set up and display the operation of specific machines in a simple and intuitive way. Thanks to the constant air quality monitoring, rooms are always healthy and pleasant to live in.

The new knx-UTA interface also allows the air handling units to be integrated into a home automation system with knx protocol for even smarter management of the entire system.

Unit	Control panels								Regulations	
	KNX-UTA	CORE AIR SPEED	CORE AIR CONTROL	EASY 3E	SMART EB	USER DYSPLAY	USER DYSPLAY TH	REMOTE CONTROL	WI / LC	CORE SYSTEM
										
REFLAIR 	✓	✓	✓						✓	✓
CHR SERIES 	✓	✓	✓						✓	✓
WHR SERIES 	WHR 150	WHR 150	WHR 150	WHR 400	WHR 400				WHR 150	WHR 150 WHR 400 with CoRe Air Conv
WHRI 		with CoRe Air Conv	with CoRe Air Conv	✓	✓					VERS. EB with CoRe Air Conv
HR SERIES 		with CoRe Air Conv	with CoRe Air Conv	✓	✓					VERS. EB with CoRe Air Conv
UAP 201-PDC 	✓	with CoRe Air Conv	with CoRe Air Conv			✓	✓		✓	with CoRe Air Conv
UC 300 V2 	✓	with CoRe Air Conv	with CoRe Air Conv			✓	✓		✓	with CoRe Air Conv
UC 360 V1 	✓	with CoRe Air Conv	with CoRe Air Conv			✓	✓		✓	with CoRe Air Conv
UC 501-MHE 	✓	with CoRe Air Conv	with CoRe Air Conv					✓	✓	with CoRe Air Conv
UC 500-MVHE 	✓	with CoRe Air Conv	with CoRe Air Conv					✓	✓	with CoRe Air Conv

CORE AIR SPEED



MODEL	CODE
CORE AIR SPEED	7041476

Core Air Speed controls the air renewal unit and displays the related data. Four capacitive touch keys let you select air flow rate, the duration of the boost and switch the unit off. A red LED warns you when the filters need to be replaced.

FEATURES

- Elect. power supply 12 V AC/DC
- 2x05 mm² twisted and shielded BUS cable
- Current consumption: 100 mA

INSTALLATION

- Horizontal wall installation on 502 or 503 box Ø 60 mm.

ELECTRICAL CONNECTIONS

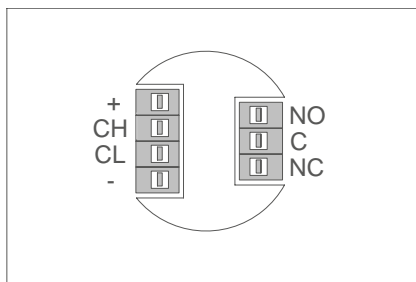

Connector		Description	Cables mm ²
+	+12 vdc	Elect. power supply	2x0,5
-	0 vdc		
CH	Can +	BUS	2x0,5 shielded
CL	Can -		

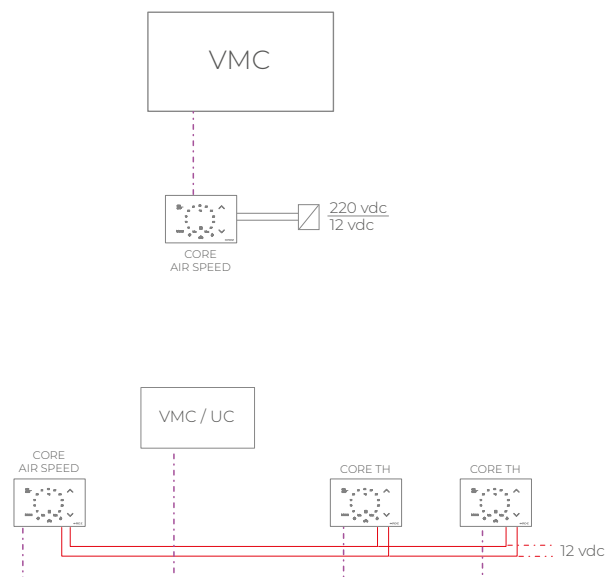

CORE AIR CONTROL



MODEL	CODE
CORE AIR CONTROL	7041477

The Core Air Control graphic interface is used to control air renewal, dehumidification and temperature. The touchscreen lets you set and display the main operating parameters of the air handling unit.

FEATURES

- Elect. power supply 12 V AC/DC
- 2x05 mm² twisted and shielded BUS cable
- Current consumption: 60 mA

INSTALLATION

- Horizontal wall installation on 502 or 503 box Ø 60 mm.

ELECTRICAL CONNECTIONS

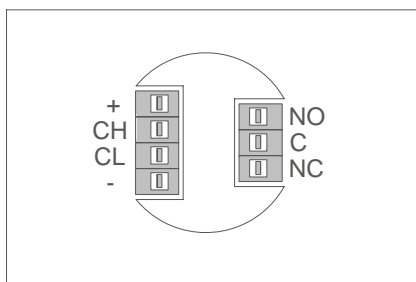

Connector		Description	Cables mm ²
+	+12 vdc	Elect. power supply	2x0,5
-	0 vdc		
CH	Can +	BUS	2x0,5 shielded
CL	Can -		

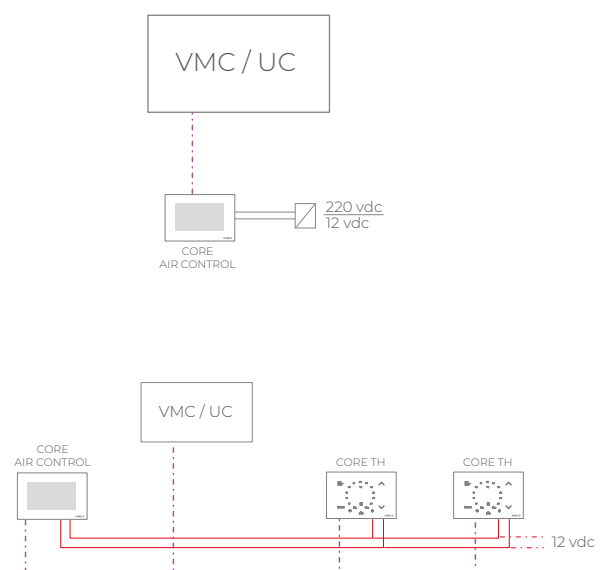

CORE AIR CONV



MODEL	CODE
CORE AIR CONV	7041481

Module for the integration of the following AHUs into the CoRe system:

UC 300 v2	UC 501 MHE	WHRI 150	HR SERIES
UC 360 v1	UC 500 MVHE	WHRI 220	DA SERIES
UAP 201-PDC	UC 500 MVHE	WHR 400	

TECHNICAL DATA

- Elect. power supply 12 V AC/DC
- 2x05 mm² twisted and shielded BUS cable
- Current consumption: 30 mA

INSTALLATION

- installation on DIN rail 3 modules

DIMENSIONS AND ELECTRICAL CONNECTIONS

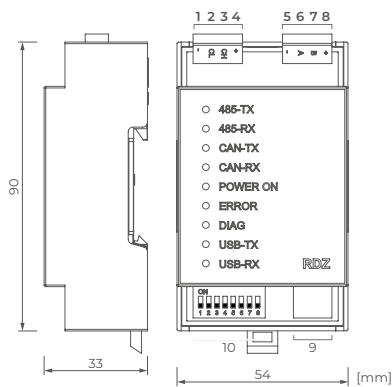

Ref.	Description
1	- Device power supply -12 VDC (-)
2	CL Reference - R-BUS port
3	CH Reference + R-BUS port
4	+ Device power supply +12 VDC (+)
5	- Device power supply -12 VDC (-)
6	A Reference + RS485 port
7	B Reference - RS485 port
8	+ Device power supply +12 VDC (+)
9	USB service interface
10	Switch SW1 (not used) - DEFAULT position, all Dip switches OFF

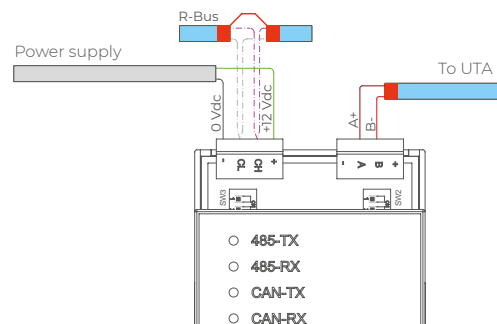

CORE CONNECT



MODEL	CODE
CORE CONNECT	6600256

CoRe Connect is a webserver allowing local and remote control (Cloud RDZ) of an RDZ thermoregulation system with CoRe system via browser and app for mobile devices. In order to take advantage of CoRe Connect's functionalities, it is necessary to power it electrically and connect it via R-bus wiring to the CoRe thermoregulation device network. A connection to a LAN network is also necessary for its use via a browser, while use via an app requires Internet access.

FEATURES

- 12 ... 24 Vdc - Connector with clamping screws
- 2x05 mm² twisted and shielded BUS cable
- LAN: Standard RJ45 connector (10/100Mbps)
- Current consumption: 3W (240 mA a 12V)

INSTALLATION

- installation on DIN rail 4 modules

DIMENSIONS AND ELECTRICAL CONNECTIONS

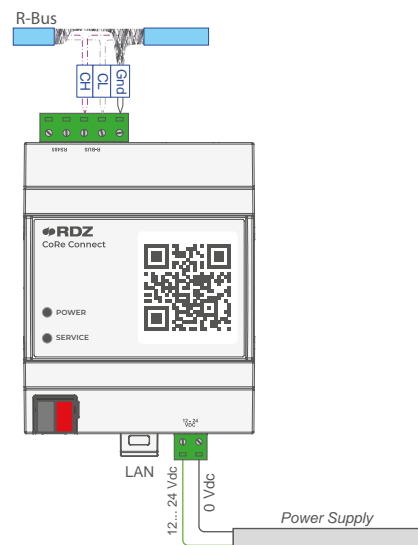
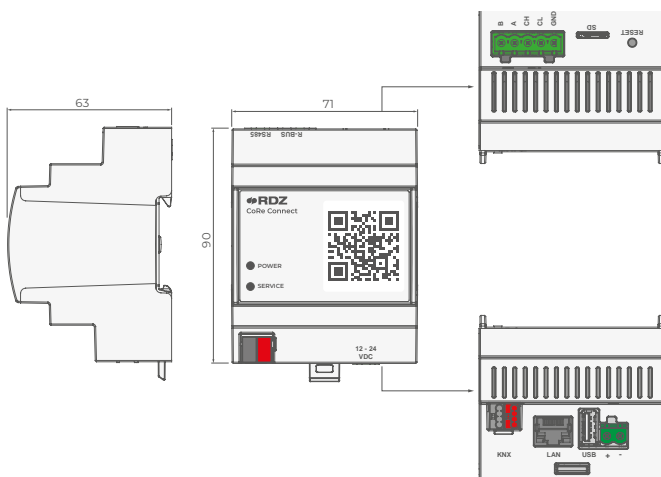

Connector	Description	Cables mm ²
KNX	KNX connection	
+	12...24 Vdc	2x0,5
-	0 Vdc	
LAN	Ethernet cable	
CH	R-Bus	2x0,5 shielded
CL		
GND		-
A	+	ModBus
B	-	

KNX-UTA - Interface



MODEL	CODE
KNX-UTA	7041480

Interface for integrating the ventilation unit into home automation systems with KNX protocol. It is possible to display operating statuses, alarms and modify the unit's operating parameters.

FEATURES

- 30 Vdc from KNX bus line
- 2x05 mm² twisted and shielded BUS cable +2x0,6 mm² KNX BUS cable
- Current consumption (from main bus line) < 13 mA

ELECTRICAL CONNECTIONS

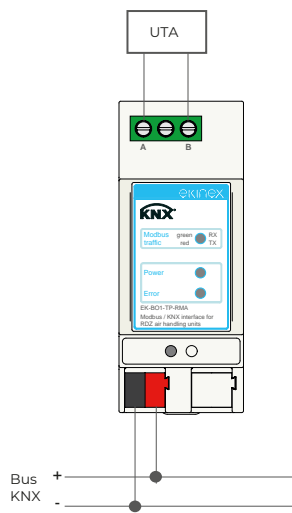

Connector	Description	Cables mm ²
A	MODBUS	2x0,5 shielded
B		
-	KNX	2x0,6
+		

INSTALLATION / CONFIGURATION

- installation on DIN rail 2 modules
 - Application program: APEKBO1RMATP##.knxprod (## = version)
- Compatible with ETS 5 program or later versions

Easy 3E - Control panel



This remote control panel can be embedded into a 503 box and connected to the unit via digital input (on-off and remote speed). It manages the following functions: switching the unit on and off, setting speed from 3 pre-set flow rates, opening and closing the by-pass, frost protection, dirty filter detection, and temperature sensor fault detection. Possibility of (automatic) control over any antifreeze element.

FEATURES

- Led for operating status and alarms
- 2 membrane buttons
- Adapters for different civil series included

INSTALLATION

Horizontal wall embedded installation on 502 or 503 box

ELECTRICAL CONNECTIONS

- RJ45 connector on panel's board and on AHU for power supply and communication
- Provided with 3 m cable
- Possibility to extend the cable up to 30 m
- Possibility to use UTP cat.5 or cat.5E straight through cable

Smart EB - Control panel



This white remote control panel can be mounted on a 503 box for protruding wall installation. It is equipped with low profile LCD as well as built-in humidity and temperature sensors. Smart EB CONTROL PANEL allows the automatic speed setting according to humidity, air quality, temperature; alternatively, it is possible to manually select 3 pre-set flow rates and diversify the speed between the supply and extract fans. Smart EB CONTROL PANEL manages the following functions: automatic opening and closing of the by-pass, frost protection, dirty filter detection, hourly or weekly scheduling, display of active alarms and alarm history, automatic control of any post-treatment batteries/heaters.

FEATURES

- 2x16 backlit LCD display
- Embedded temperature and humidity probe
- 5 membrane buttons

INSTALLATION

Horizontal wall installation on 502 or 503 box

User Display - Control panel



MODEL	CODE
USER DISPLAY	7041470
TH USER DISPLAY	7041475

LCD room thermostat with 320x240 pixel screen resolution, 16 colours, built-in fonts and 6 capacitive touch keys. It shows working conditions and alarms, and it is used to change the parameters of the air handling unit. Furthermore, the user can set the time slots, the operating mode as well as the air flow rate during ventilation.

The **USER DISPLAY TH** version is equipped with temperature and humidity sensors to control the dehumidification and the integration of sensible capacity in both summer and winter.

FEATURES

- Backlit graphic LCD display
- Resolution 320x240 pixel
- 6 capacitive keys
- Temperature and relative humidity probe embedded in TH version

ELECTRICAL CONNECTIONS

Ref.	Connector	Description	Cables
A	3	24V-	Elect. power supply
	4	24V+	
B	2	CAN+	Communication
	1	CAN-	

Micro-switch	Description
1	not used
2	Position micro-switch 2 on position ON to plug in the termination of the CAN port

INSTALLATION

Horizontal wall installation on 502 or 503 box

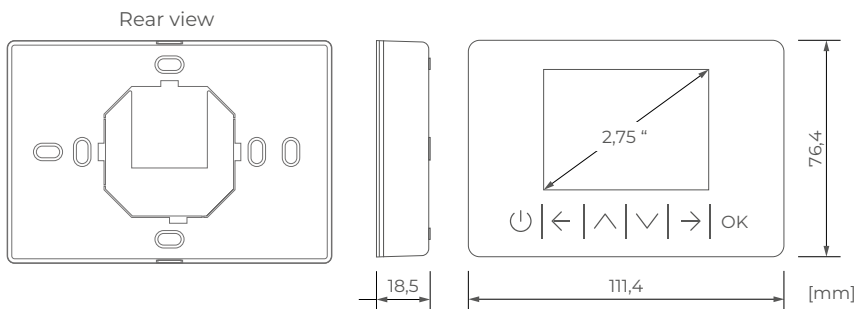

Led	
	ON/STAND-BY
	ALLARMS
	POWER
Tasti	
	ON/STAND-BY
	LEFT
	UP
	DOWN
	RIGHT
	ENTER

Remote Control - Type 1



MODEL	CODE
REMOTE CONTROL for UC 500-MVHE	7041460
REMOTE CONTROL for UC 501-MHE	7041465

DIN rail control panel (6 modules) for displaying operations and setting unit parameters. The signals for dehumidification, summer/winter integration, boost, and free-cooling must be connected to the panel. Fresh air ventilation can be activated manually or by time scheduling.

FEATURES

- Power Supply: 24 Vac
- Digital inputs for unit management
- BUS connection for displaying operations and setting unit parameters

ELECTRICAL CONNECTIONS

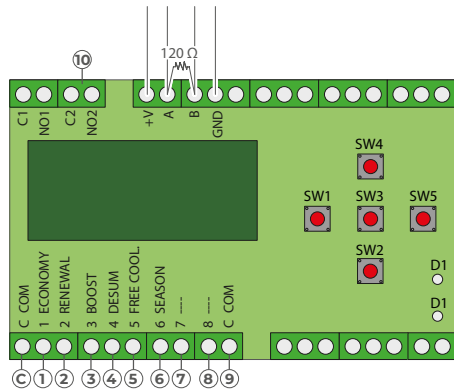

Ref.	Connectors	Description	Cables
1	C	+1	Economy
2	C	+2	Renewal
3	C	+3	Booster
4	C	+4	Deshumidif.
5	C	+5	Free-cooling
6	C	+6	Season
7	--	+7	
8	--	+8	
9	C	--	
10	C2	+ NO2	Alarm output
	+V		Elect. power supply
	GND		
	A		BUS communication
	B		

2x0,5 mm²

2x0,5 mm²
Shielded

INSTALLATION

Installation on DIN rail 6 modules

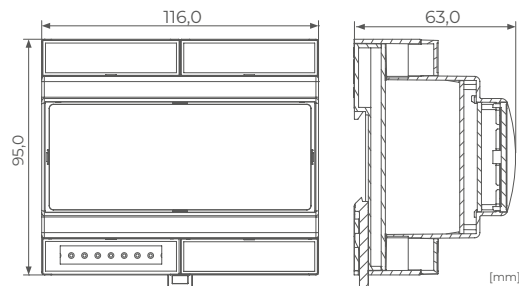



SF-M

Condensate drain kit consisting of a siphon with silicone membrane, hose and fitting, to be used in combination with RDZ air handling units.

Model	Code	Ø IN mm	Ø OUT mm	Units
SF-M 13	3600401	13	32	CHR / WHR 150 / UAP 201-PDC / UC 501-MHE / SR 701-1001-2001 Series
SF-M 15	7045556	15		WHR 400 / UC 300 V2 / UC 360 V1
SF-M 20	3600400	20		DA 701-1001-2001 / UC 500-MVHE

INSTALLATION



SF-P N

Condensate drain kit with casing, designed for wall installation. It can be used in combination with RDZ air handling units, and it is suitable for Ø 20-32 mm piping. The external shell can be adjusted considering the thickness of the wall. Washable condensate trap.

Code	Ø mm entry	Ø mm exit	Units
7045504	20-32	25	CHR / UAP 201-PDC UC 300 V2 / UC 360 V1 / UC 501-MHE Series

INSTALLATION

FLOW METERS

Direct hydraulic balancing and control of flows to consumers or in a subsystem. Balancing valves offer a quick, easy and accurate method of adjusting the flow rates through heating, ventilation, air conditioning and cooling systems. Correct balancing of hydraulic circuits ensures optimum energy distribution, resulting in more efficient and economical operation in accordance with the energy saving regulations provided for by legislation. With flow measuring unit, any qualified fitter can set the appropriate flow rate using the unique flow measurement device, avoiding investments in training and costly measuring devices.

MP 2-8

Flow meter \varnothing $\frac{3}{4}$ " Eurocone

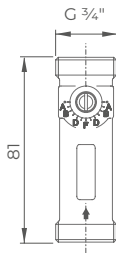

SIZE	KV	CODE
\varnothing $\frac{3}{4}$ " M	1.8	7045554

General features	Value	U.M.
Operating pressure PO max:	10	bar
Measuring accuracy:	± 10 % of the indicated value	
kVS value:	1.8	kVS
Measurement range:	2.0 - 8.0	(l/min)

MP 2-12

Flow meter \varnothing $\frac{3}{4}$ "

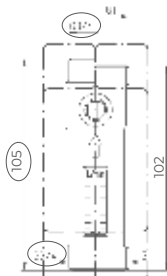

SIZE	KV	CODE
\varnothing $\frac{3}{4}$ " M	3.0	7045557

General features	Value	U.M.
Operating temperature	120, short-term 160	$^{\circ}$ C
Operating pressure PO max:	10	bar
Measuring accuracy:	2.0 - 12	(l/min)
Housing:	15	DN
System connections	G $\frac{3}{4}$ x G $\frac{3}{4}$	
Mounting position	Horizontal, tilted or vertical	

MP 5-42 and MP 20-70

Flow meter \varnothing 1"

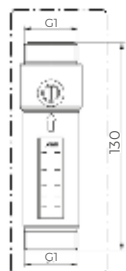

SIZE	KV	CODE
\varnothing 1" M	9.7	7045558
\varnothing 1" M	12.9	7045559

General features	Value	U.M.
Operating temperature	120, short-term 160	$^{\circ}$ C
Operating pressure PO max:	10	bar
Measuring accuracy:	5.0 - 42.0 20.0 - 70.0	(l/min)
Housing:	20	DN
System connections	G1 x G1	
Mounting position	Horizontal, tilted or vertical	

MODULATING VALVE

Modulating water valve for da units

Valve with modulating actuator to manage room air temperature in winter. It is monitored directly by DA units. This valve can also control the air temperature in the summer if the compressor is still.

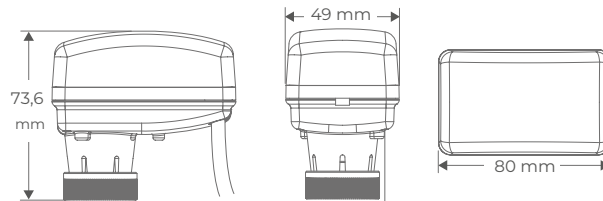

SIZE	SERVOMOT.	CODE
Ø 3/4"	0-10V	7041170
Ø 3/4"	0-10V	7041180
Ø 1"	0-10V	7041190

TECHNICAL SPECIFICATIONS

FEATURES	Value	U.M.
Action control	Proportional	
Supply voltage	24VAC +/-15% - 24VDC +/-15%	
Input impedance	>100	kΩ
Voltage	500	Ω
Current		
Power consumption		
Apparent	2,5	VA
Active	1,5	W
Nominal force	120	N
Maximum mechanical stroke	6,3	mm
Running time	8	sec/mm
Protection	IP43	
Thread nut connection	M30 x 1,5	
Ambient operating condition	0 ÷ 50	°C (not condensing)
Ambient storage condition	-20 ÷ 65	°C (not condensing)
Max. fluid temperature	95	°C

VALVE BODY DIMENSIONS AND PRESSURE DROPS

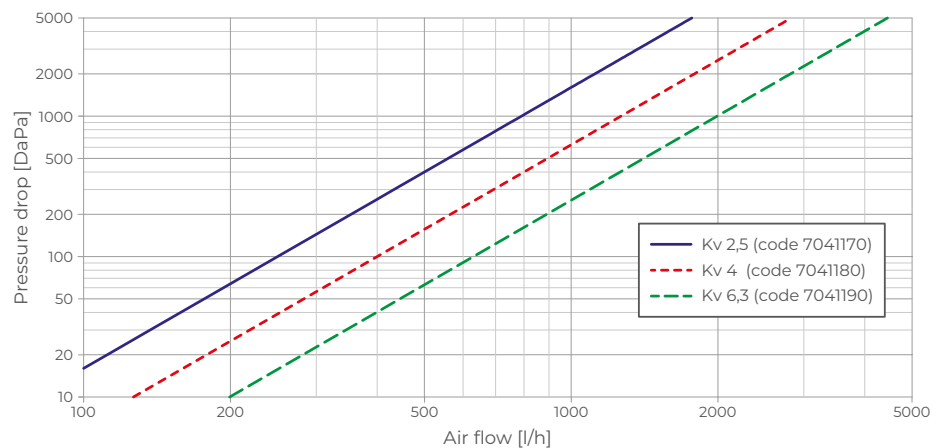
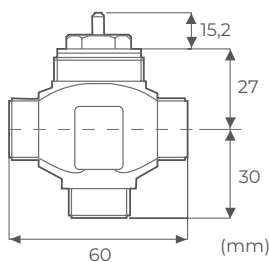



Standard duct heater with 1 or 2 stage electrical element mounted on galvanized steel plate. It can be used to prevent freezing or for post-heating, depending on the installation position. It is also provided with control and safety thermostat.

SUMMARY OF FEATURES

Name	Code	Power	Stage n°	Elect. power supply	Nominal flow rate	Nominal air ΔT	Minimum flow rate*
		[kW]			[m³/h]	[°C]	[m³/h]
RE-S 05-125	7045565	0,5	RC	230 V1F	150	12,5	50
RE-S 075-160	7045567	0,75			220	12,7	80
RE-S 10-160	7045569	1			350	10,7	110
RE-S 15-200	7045571	1,5			500	11,2	160
RE-S 20-250	7045573	2	RF	400 V 3 PH	800	9,3	215
RE-S 30-315	7045575	3			1200	9,3	320
RE-S 40-315	7045577	4			1600	9,3	430
RE-S 60-355	7045579	6			2200	10,2	640
RE-S 120-400	7045581	12			3200	14,0	1280
RE-S 160-400	7045583	16			4000	14,9	1710
RE-S 160-450	7045585	16			5000	12,0	1710

RC = Armored Resistance; RF = Wire Resistance
 * to avoid triggering the automatic thermostat, with inlet air at 20 ° C and maximum power (all stages active)

CONNECTIONS AND DIMENSIONS

Name	Connections		Dimensions				
	IN	OUT	∅	L	P	H	S
RE-S 05-125	M		125	400	300	220	125
RE-S 075-160			160	400	300	245	160
RE-S 10-160			160	400	300	245	160
RE-S 15-200			200	400	300	290	200
RE-S 20-250	F	M	250	400	300	355	160
RE-S 30-315			315	400	300	450	200
RE-S 40-315			315	400	300	450	200
RE-S 60-355			355	400	300	490	210
RE-S 120-400			400	400	300	495	260
RE-S 160-400			400	400	300	550	260
RE-S 160-450			450	400	300	580	260

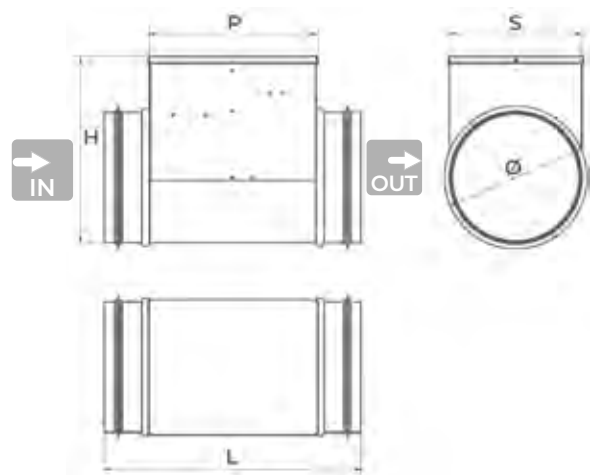

ELECTRICAL CONNECTIONS

1 stage resistance

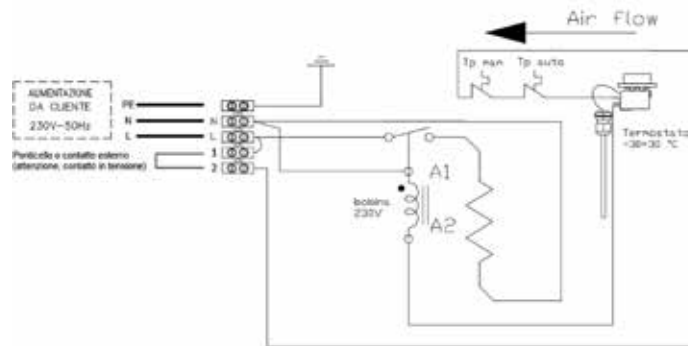

2 stages resistance

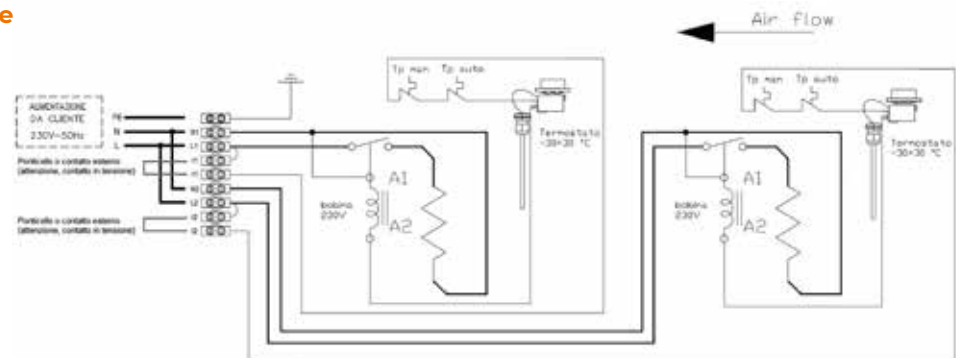

2 stages resistance three-phase

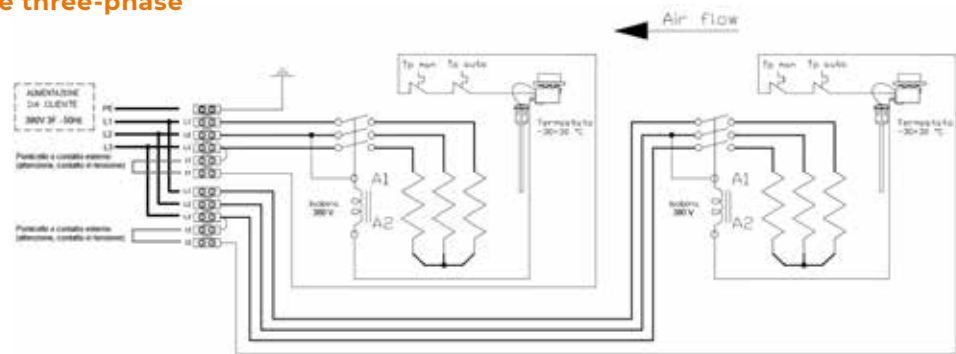

INSTALLATION

Vertical or horizontal.

If installation is made horizontally, the wiring box shall be installed as following shown:

Horizontal

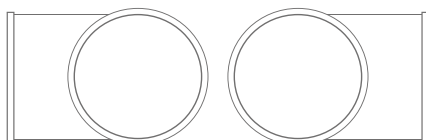

Not recommended positions

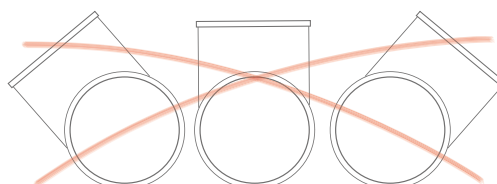

Vertical





Heater with electrical duct element mounted on galvanized steel plate. It can be used to prevent freezing or for post-heating, depending on the installation position. It is also provided with safety thermostat and 0-10 V electronic control managed by the unit.

SUMMARY OF FEATURES

Name	Code	Power	Stage n°	Elect. power supply	Nominal flow rate	Nominal air ΔT	Minimum flow rate*
		[kW]			[m³/h]	[°C]	[m³/h]
RE-M 05-125	7045566	0,5	RC	230 V1F	150	12,5	50
RE-M 075-160	7045568	0,75			220	12,7	80
RE-M 10-160	7045570	1			350	10,7	110
RE-M 15-200	7045572	1,5			500	11,2	160
RE-M 20-250	7045574	2	RF	230 V1F	800	9,3	215
RE-M 30-315	7045576	3		400 V3 PH	1200	9,3	320
RE-M 40-315	7045578	4			1600	9,3	430
RE-M 60-355	7045580	6			2200	10,2	640
RE-M 120-400	7045582	12			3200	14,0	1280
RE-M 160-400	7045584	16			4000	14,9	1710
RE-M 160-450	7045586	16			5000	12,0	1710

RC = Armored Resistance; RF = Wire Resistance
 * to avoid triggering the automatic thermostat, with inlet air at 20 ° C and maximum power (control set to 10 V)

CONNECTIONS AND DIMENSIONS

Name	Connections		Dimensions				
	IN	OUT	∅	L	P	H	S
			[mm]				
RE-M 05-125	M		125	400	300	220	125
RE-M 075-160			160	400	300	245	160
RE-M 10-160			160	400	300	245	160
RE-M 15-200			200	400	300	290	200
RE-M 20-250	F	M	250	400	300	355	160
RE-M 30-315			315	400	300	450	200
RE-M 40-315			315	400	300	450	200
RE-M 60-355			355	400	300	490	210
RE-M 120-400			400	400	300	495	260
RE-M 160-400			400	400	300	550	260
RE-M 160-450			450	400	300	580	260

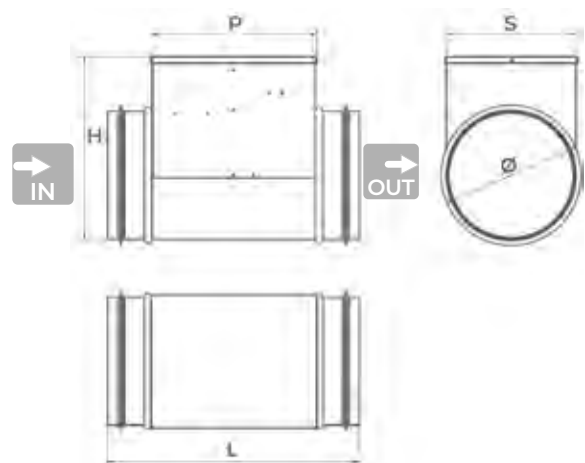

ELECTRICAL CONNECTIONS

0-10 V single-phase

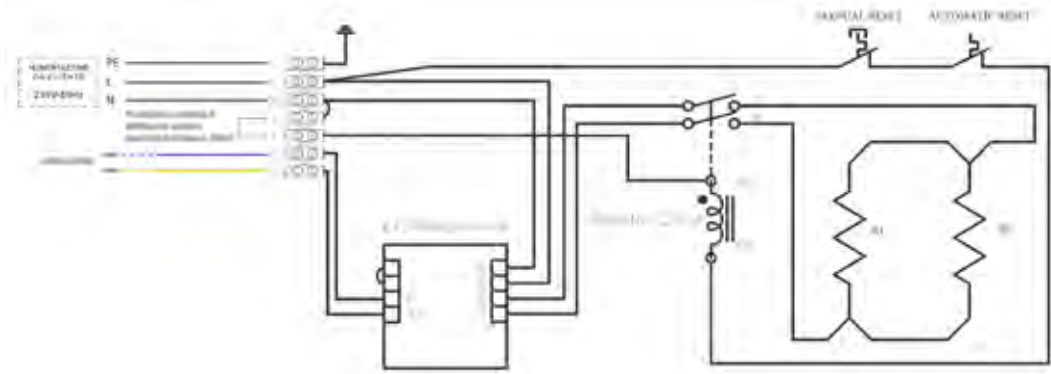

0-10 V three-phase

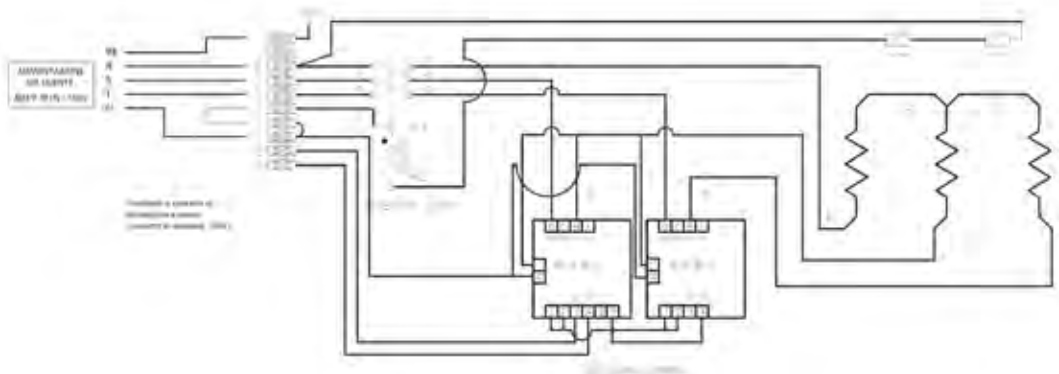

INSTALLATION

Vertical or horizontal.

If installation is made horizontally, the wiring box shall be installed as following shown:

Horizontal

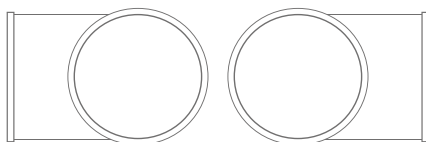

Not recommended positions

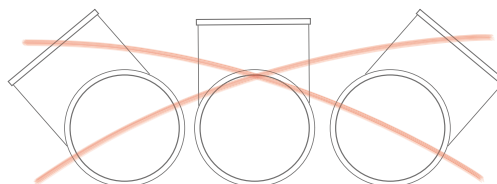

Vertical





Hot and/or cold water duct battery to bring room air to the required temperature.

SUMMARY OF FEATURES

Name	Code	Air flow m ³ /h	Power kW	Air con- nect.	Water connect.	Con- densate drain	Size LxHxD mm	Empty weight kg	Water content l
BA-C 32-200	7045590	500	3,2	Ø 200	½" F	13 mm	460 x 270 x 300	12,9	0,53
BA-C 57-250	7045591	800	5,7	Ø 250			650 x 330 x 300	18,2	1,35
BA-C 97-315	7045592	1200	9,7	Ø 315	¾" F		785 x 430 x 350	38,9	5,0
BA-C 125-315	7045593	1600	12,5	Ø 315			780 x 520 x 350	43,3	6,0
BA-C 184-355	7045594	2200	18,4	Ø 355	1" F		780 x 520 x 400	49,7	8,0
BA-C 269-400	7045595	3200	26,9	Ø 400			895 x 660 x 450	66,9	12,0
BA-C 340-400	7045596	4000	34,0	Ø 400	1" F		1000 x 740 x 450	79,1	15,0
BA-C 402-450	7045597	5000	40,2	Ø 450			1000 x 740 x 450	79,1	15,0

INSTALLATION

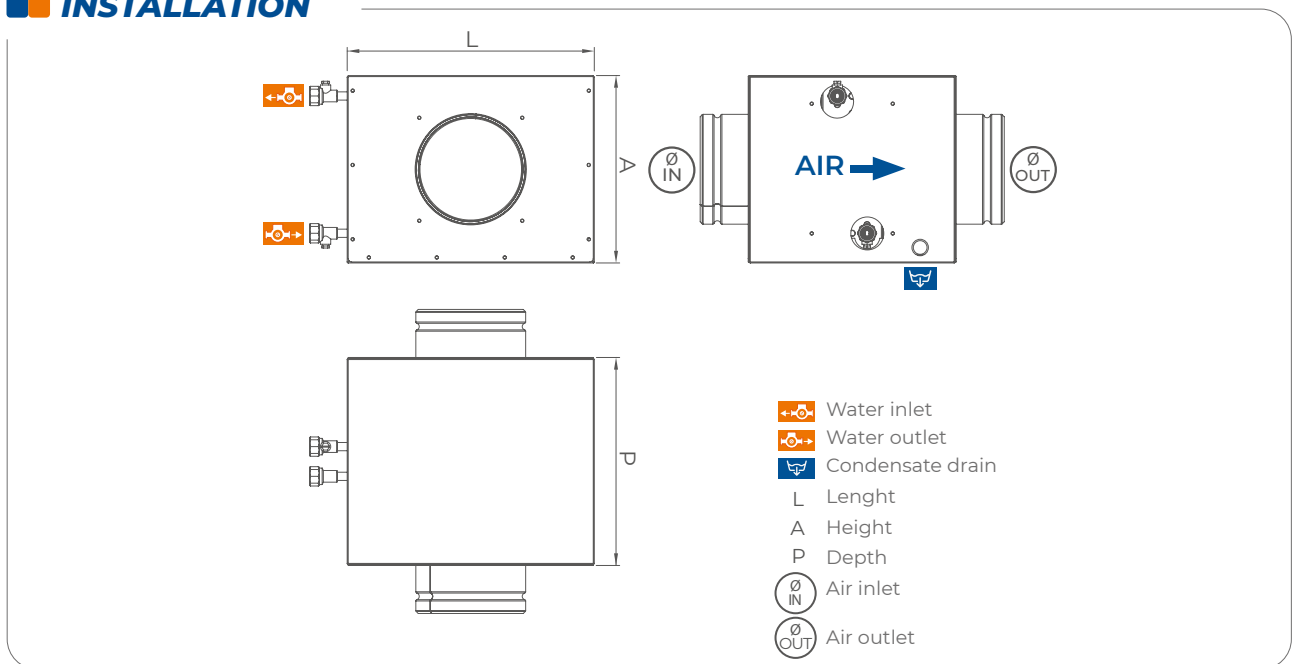

PERFORMANCE

Name	Code	PERFORMANCE IN HEATING MODE									
		Air flow		Power		Air		Water flow		ΔP	
						IN	OUT			Water	Air
		Total		Temp.							
m ³ /h	m/s	kW	°C		l/h	m/s	kPa	Pa			
BA-C 32-200	7045590	500	1,60	3,2	20	38,7	549	1,00	13,4	14	
BA-C 57-250	7045591	800	1,40	5,7	20	41,0	985	1,00	11,9	13	
BA-C 97-315	7045592	1200	1,39	9,7	20	44,0	1689	1,22	19,5	20	
BA-C 125-315	7045593	1600	1,54	12,5	20	43,2	2177	1,08	12,9	24	
BA-C 184-355	7045594	2200	2,12	18,4	20	44,8	3200	1,17	14,2	54	
BA-C 269-400	7045595	3200	2,12	26,9	20	44,9	4682	1,37	19,5	54	
BA-C 340-400	7045596	4000	2,04	34,0	20	45,2	5923	1,44	24,4	50	
BA-C 402-450	7045597	5000	2,55	40,2	20	43,9	7007	1,69	29,7	73	

Water Inlet: 50°C - Outlet: 45°C

Name	Code	PERFORMANCE IN COOLING MODE										
		Air flow		Power		OUT		Water flow		ΔP		Con-dens.
						Temp.	Umid.			Water	Air	
		Total	Sensi.	°C	%rH							
m ³ /h	m/s	kW		°C	%rH	l/h	m/s	kPa	Pa	l/h		
BA-C 32-200	7045590	500	1,60	3,1	1,7	16,7	84,9	523	1,00	15,1	20	2,1
BA-C 57-250	7045591	800	1,40	5,7	3,1	15,1	88,1	981	1,00	14,5	20	4,0
BA-C 97-315	7045592	1200	1,45	7,8	4,9	15,1	99,8	1334	0,96	15,9	54	4,0
BA-C 125-315	7045593	1600	1,61	9,7	6,2	15,6	99,4	1664	0,80	10,0	63	4,8
BA-C 184-355	7045594	2200	2,22	15,1	9,2	14,6	100,0	2601	0,94	15,5	113	8,2
BA-C 269-400	7045595	3200	2,21	22,5	13,7	14,5	100,0	3863	1,12	20,0	113	12,3
BA-C 340-400	7045596	4000	2,14	28,7	17,2	14,3	100,0	4929	1,19	21,8	108	15,9
BA-C 402-450	7045597	5000	2,67	30,7	19,3	15,7	97,5	5273	1,27	24,7	113	15,8

Water inlet: 7°C - Outlet: 12°C

Air inlet: 27°C - 60% R.H.

PERFORMANCE

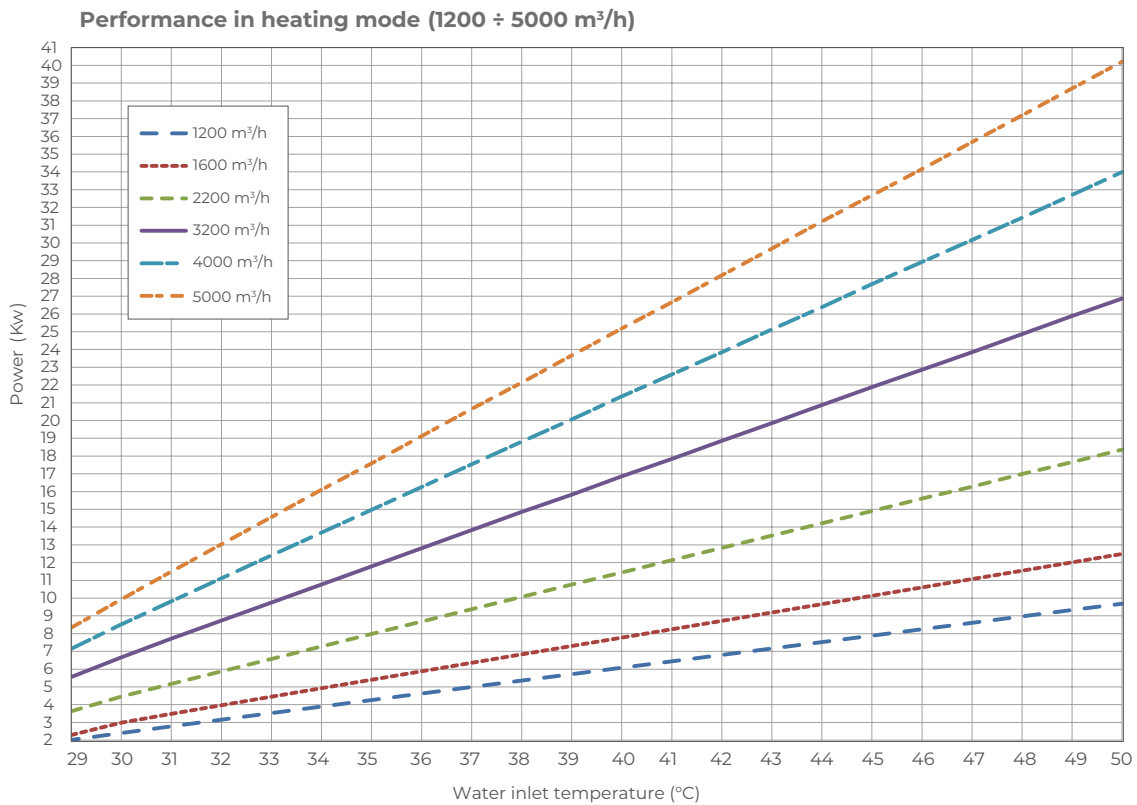
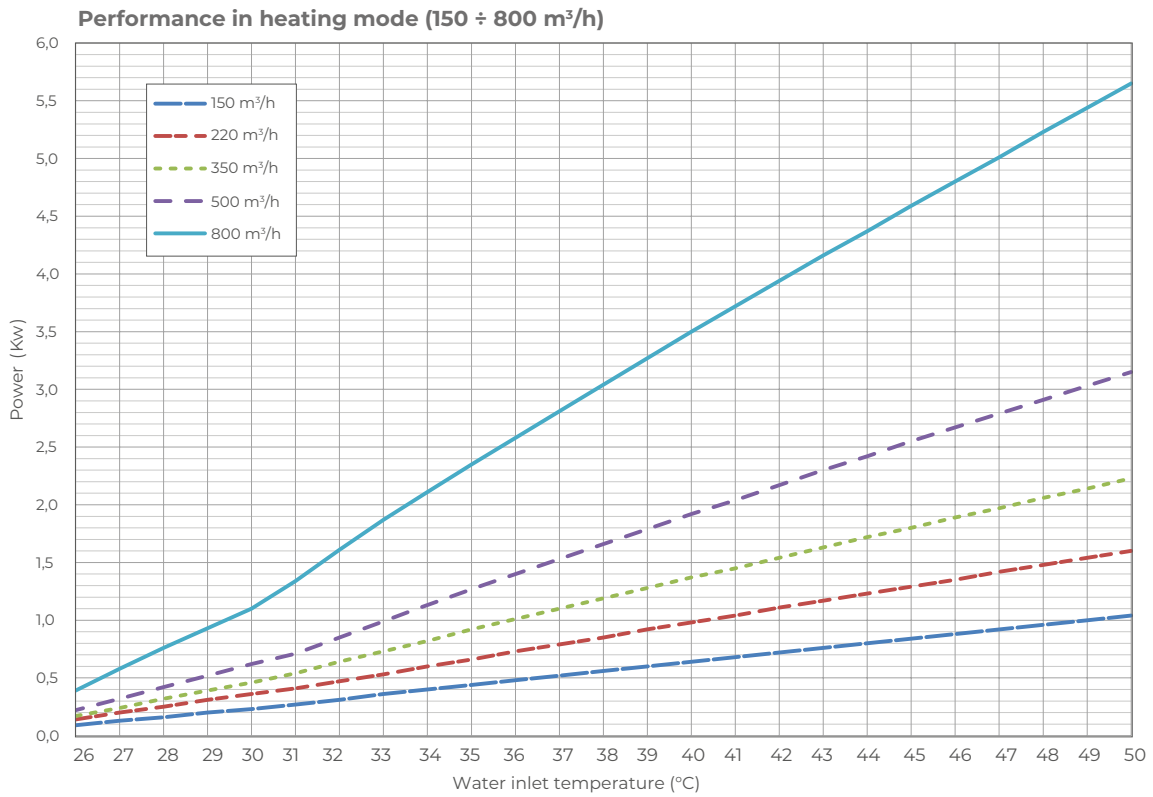



Air-water exchanger for PLD distribution box, design to bring air to the desired temperature through heating, cooling and dehumidification.

SUMMARY OF FEATURES

Name	Code	Power heating	Code reference valve	Empty weight	Size LxAxP mm	Water content
BA-P 6	7045598	2.5 kW	7045562	7.5 Kg	310x200x300	1.0 L
BA-P 10	7045599	5 kW	7045562	10.5 Kg	360x270x300	1.5 L

INSTALLATION

Ceiling installation

Wall installation

L Length
A Height
P Depth

- Water inlet
- Water outlet
- Condensate drain

HEATING PERFORMANCE

BA-P 6 AIR (IN) 19 °C - 45 % U.R.

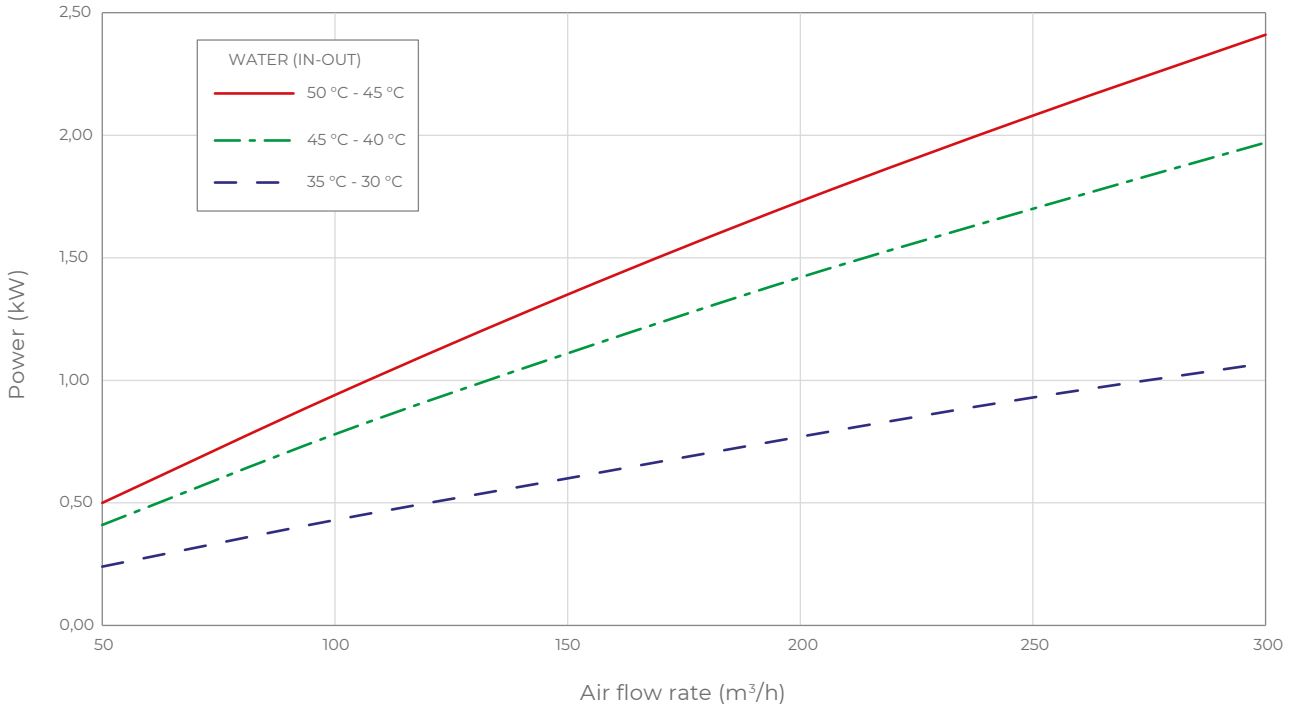

BA-P 10 AIR (IN) 19 °C - 45 % U.R.

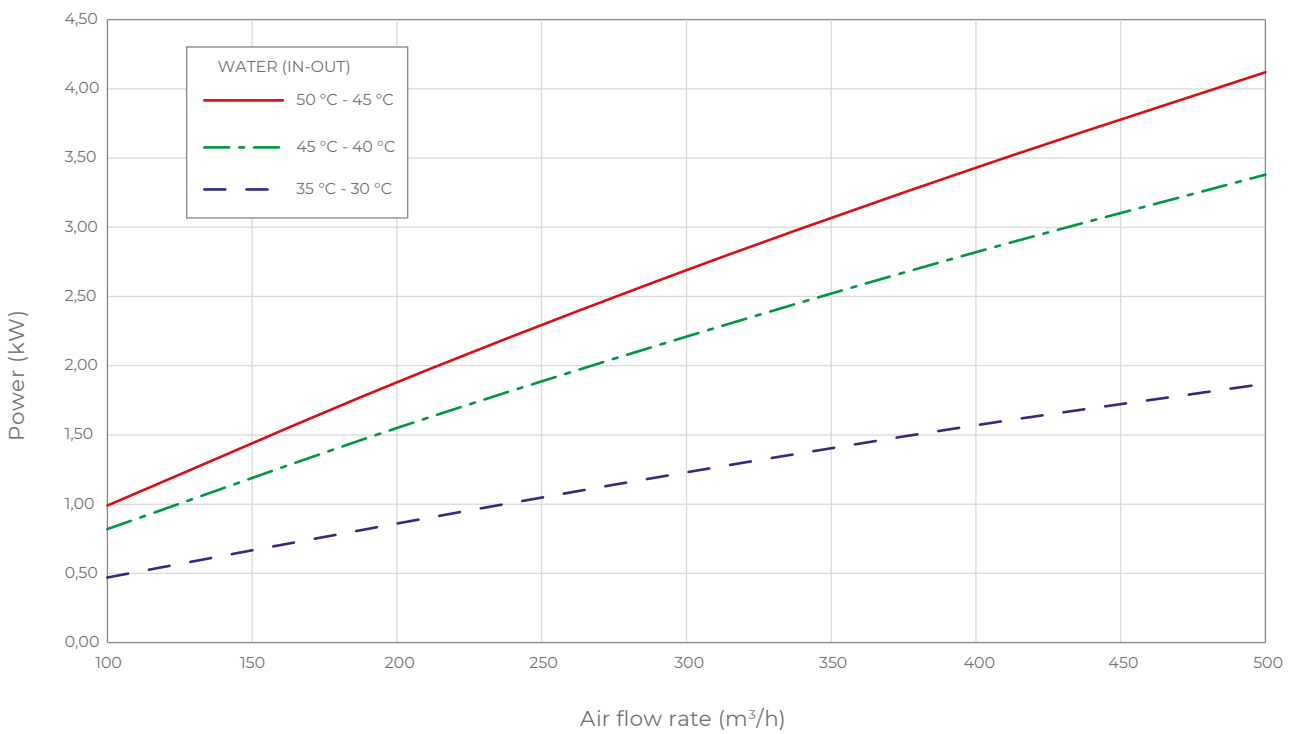

COOLING PERFORMANCE

BA-P 6

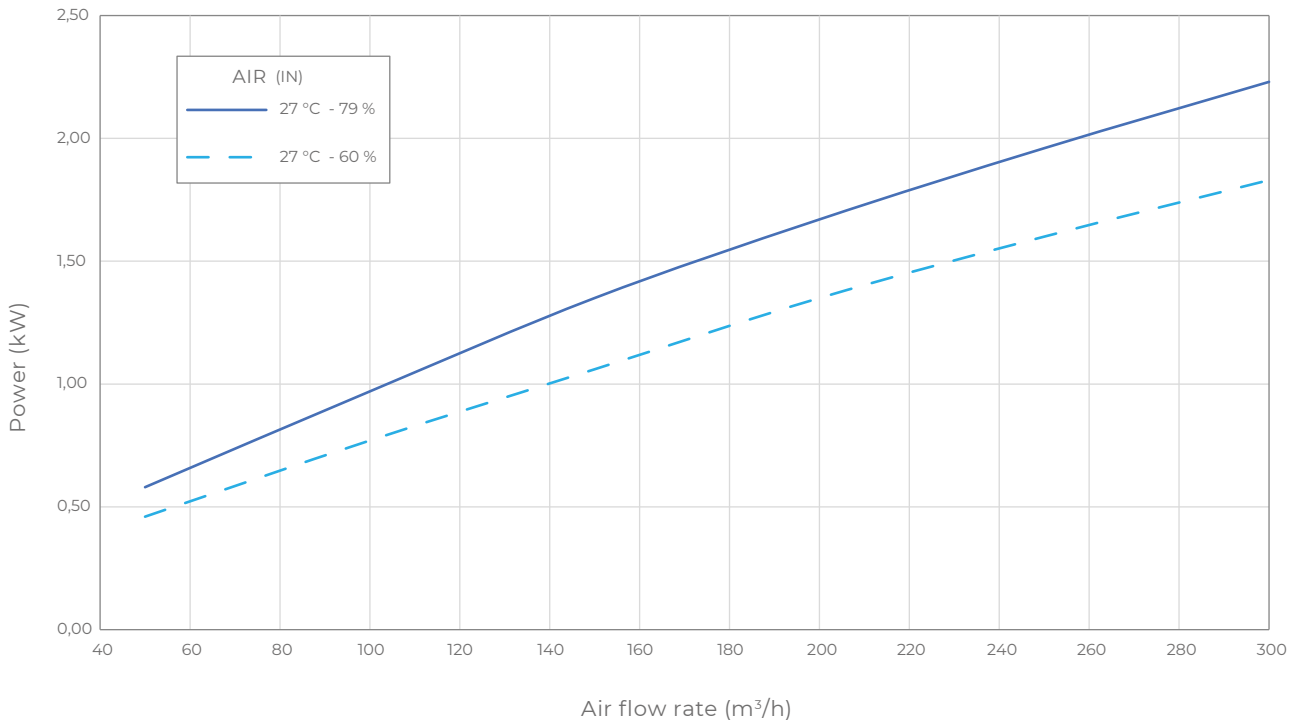

BA-P 10

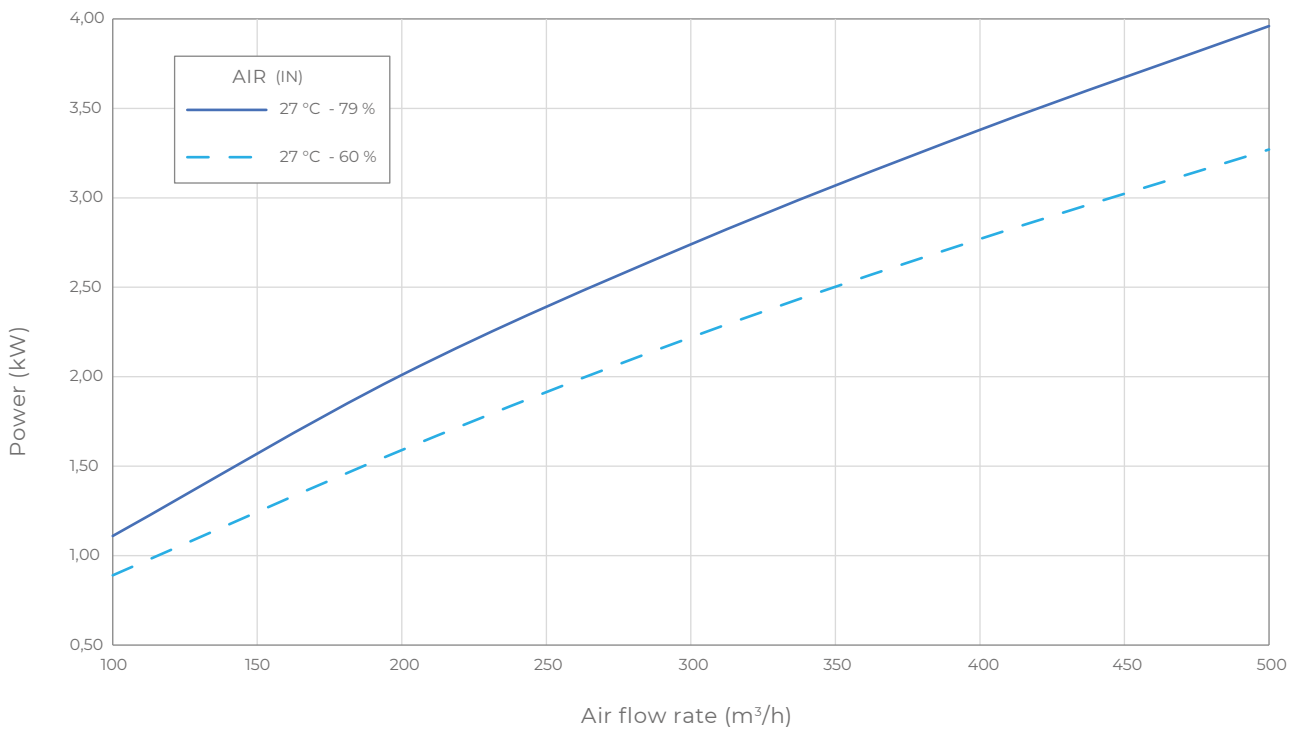

■ ■ PRESSURE DROPS

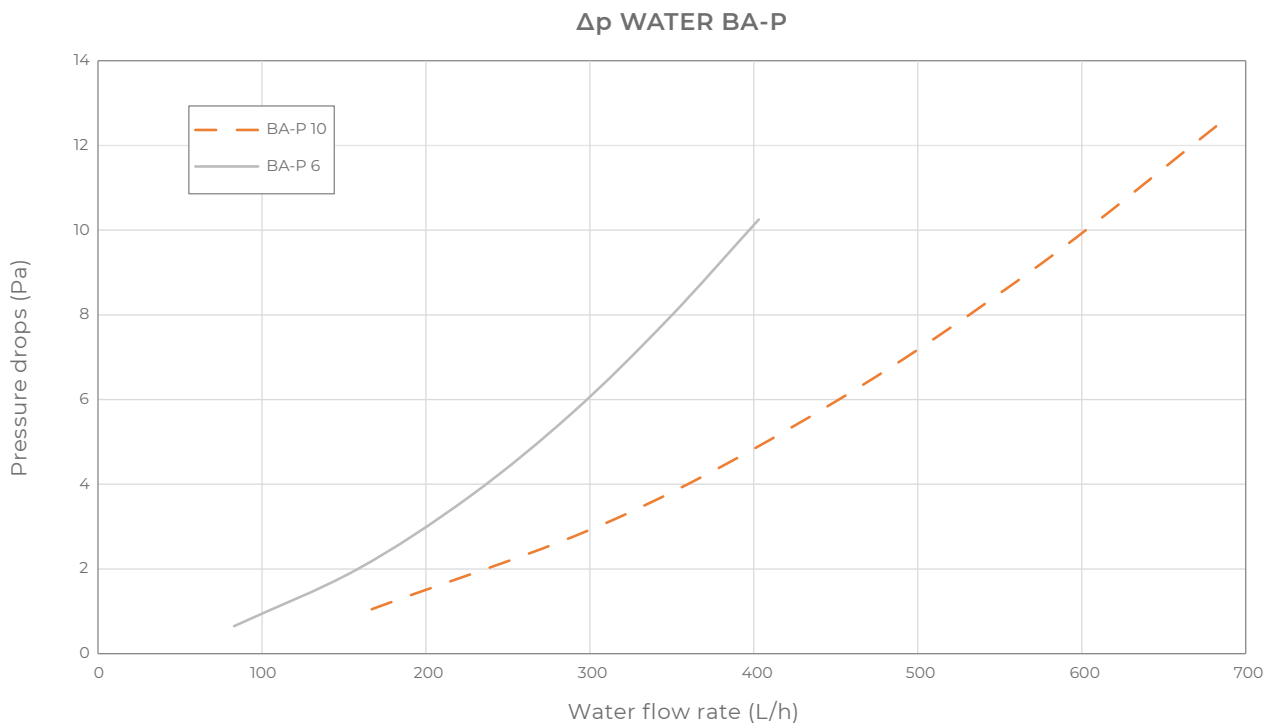
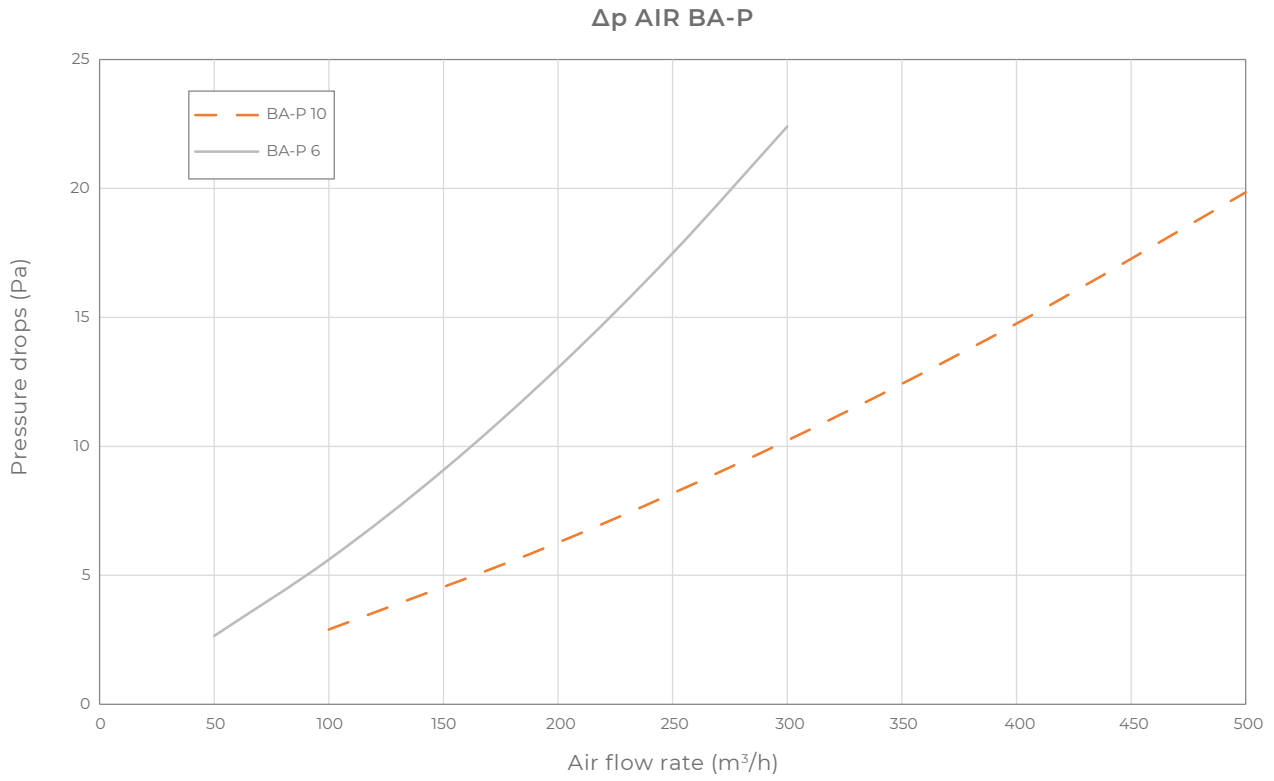



Air distribution system





The modular and invisible solution to supply fresh and clean air to every room

With the modern manufacturing technology and the growing awareness regarding energy saving, the new trend in the construction field promotes buildings, which become more and more insulated from the thermal standpoint but deficient in ventilation, i.e. in the natural and spontaneous exchange of the room air through windows and walls.

In order to ensure maximum health and living comfort all year round, we have enriched our product range with a series of ductable units for ventilation and air handling in residential buildings, which can be combined with a suitable air distribution system.

This is made by a series of channels that carries the **clean and dehumidified air** to the rooms, taking stale air from them and conveying it outside.

A wide range of ducts, plenums, vents and accessories completes the system and allows it to be customized according to design and site requirements.

Thanks to the **high modularity** of all components, installation is easy and quick.

AIR DISTRIBUTION SYSTEM ADVANTAGES:



MODULAR, QUICK AND EASY INSTALLATION



LOW NUMBER OF COMPONENTS



COMPLETE RANGE OF PRODUCTS



EASY MAINTENANCE AND CLEANING



POSSIBILITY OF CEILING, FLOOR AND WALL INSTALLATION

EXAMPLE OF AIR DISTRIBUTION SYSTEM

The image below represents a possible configuration for air distribution system with rigid ducts for main air ductworks.

The main air ductwork is made with **EPE system** in expanded polyethylene, made up of elastic and resistant components that offer excellent thermal insulation performance and low pressure drops thanks to the smooth inner surface. Lightweight and modular, it lends itself to practical and quick installation, and guarantees a pleasant and well-finished aesthetic result.

The room air ductwork is made with **Duo White system**: semi-rigid ducting, accessories and air distribution boxes. Thanks to the use of Sanitized® technology, the components are sanitized for their entire life cycle. The modular composition of air distribution boxes allows to customize the system starting from a few basic elements, in order to satisfy any design or installation need.

Metal grilles and circular air extraction valve, that are characterized by elegant and minimal design, complete the room air ductwork, while the round outdoor ventilation grilles protect the ducting.

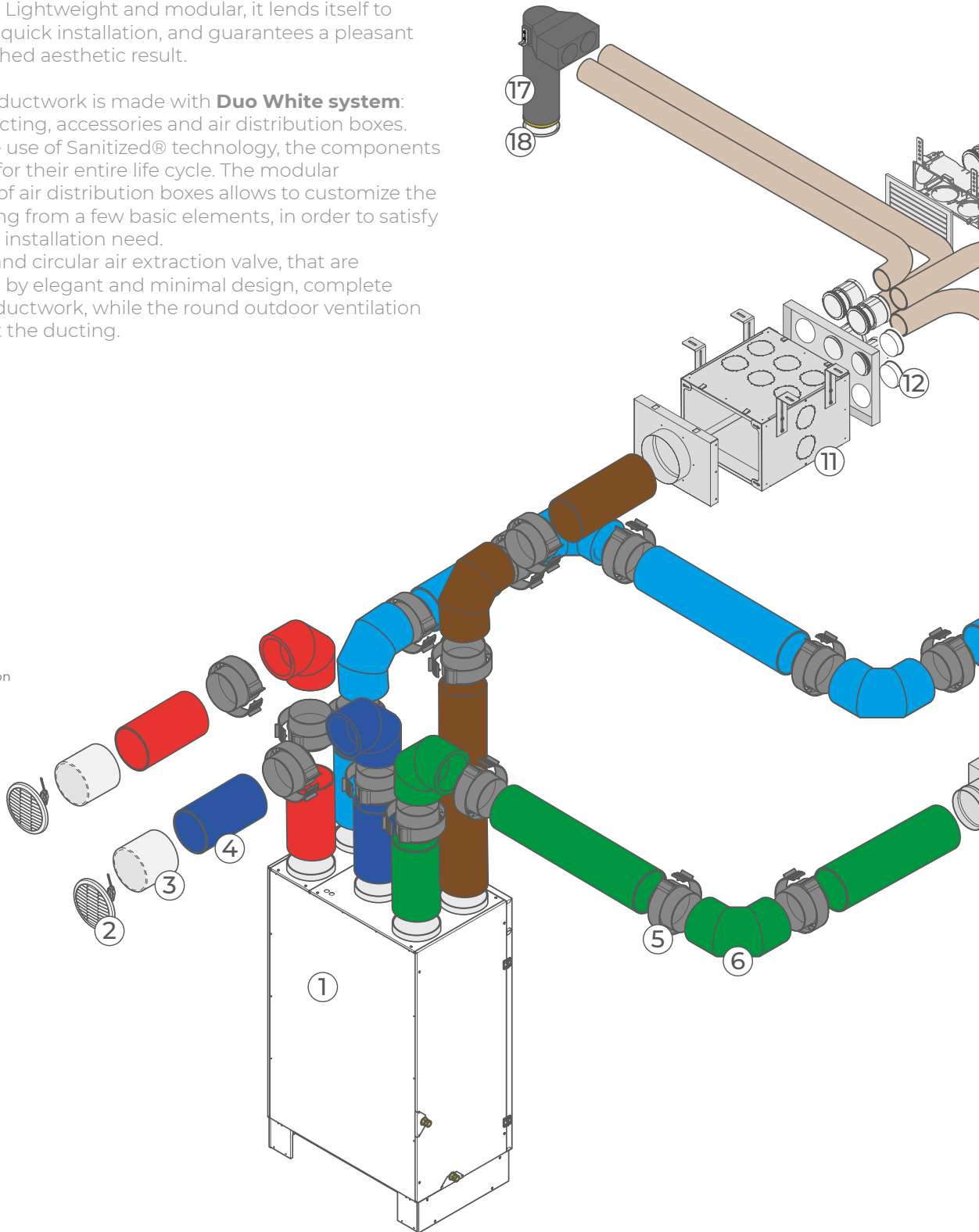

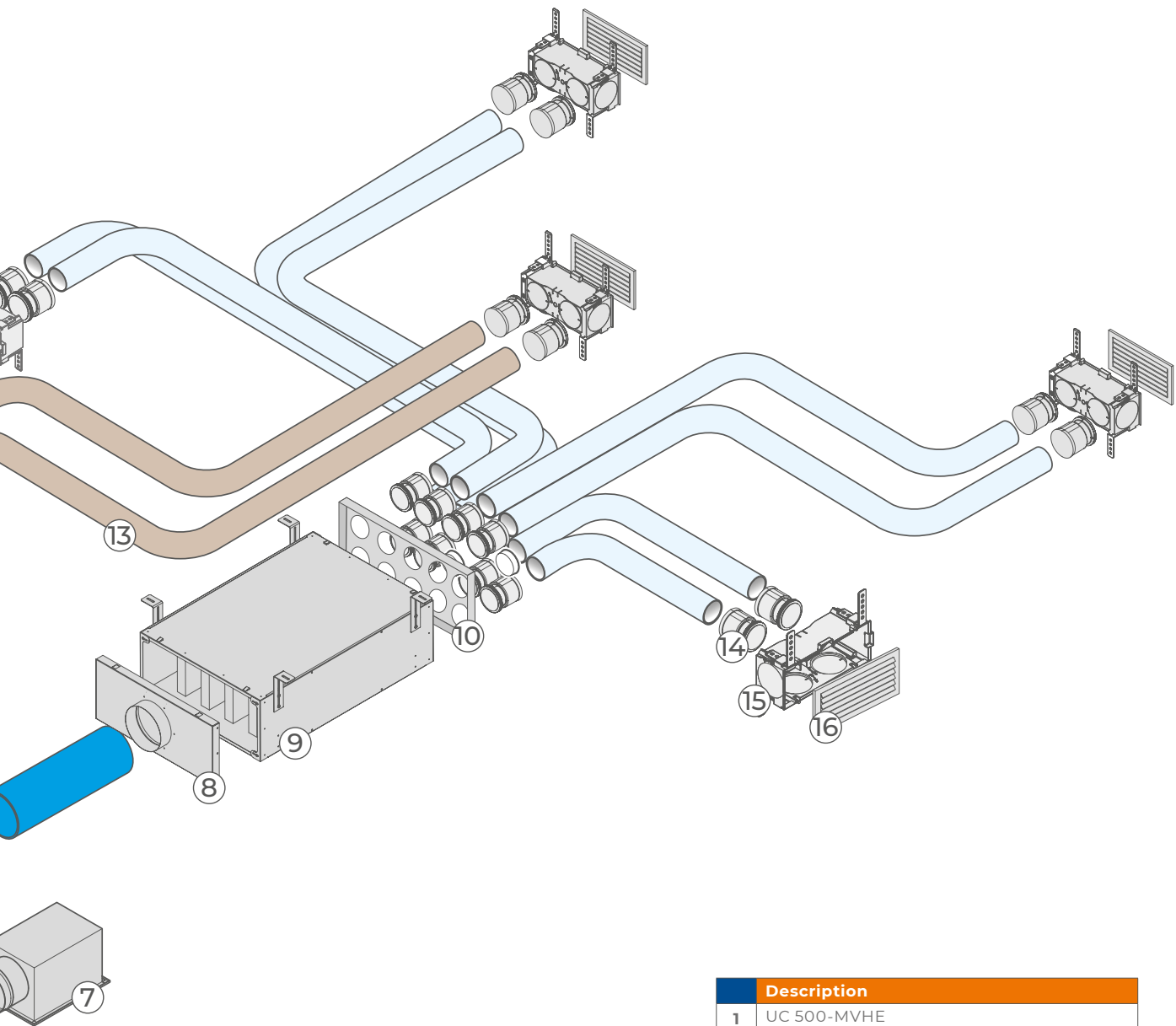

	Description
1	UC 500-MVHE
2	Ventilation air grille
3	Wall crossing
4	EPE pipe
5	EPE connector
6	EPE bend
7	Air grille 400x100 mm
8	Cover for PLD-TC
9	PLD-S Silenced distribution box
10	PLD-CD Cover for room air distribution
11	PLD-U Universal distribution box
12	TPL Blanking cap
13	Duo White ducting
14	RDW connector
15	PLA 2 Room plenum
16	Room grille
17	Duo White circular room plenum
18	Extract air valve

EXAMPLE OF AIR DISTRIBUTION SYSTEM

The image below represents a possible configuration for air distribution system with flexible ducts for main air ductworks.

Flex system connects the AHU unit to the outside and with the air distribution boxes. Central element of this solution is the flexible ducting, available in different variants with thermal and acoustic insulation performances. Light and resistant, it's easy to install and ideal as main air ductwork for horizontal AHU placed in the false ceiling.

The room air ductwork is made with **Duo White system**: a set of sanitized semi-rigid ducts and accessories. Thanks to the use of ducts with reduced section, is possible to realize a system with minimum lowering of the ceiling.

The extraction ducts convey the polluted air into PLD-U modular air distribution box made of galvanized steel plate with soundproofing insulation; from the PLD-S, modular air distribution box with soundproofing baffles, departs the air ductworks to the rooms.

Semi-rigid ducting, accessories and air distribution boxes. Thanks to the use of Sanitized® technology, the components are sanitized for their entire life cycle. The modular composition of air distribution boxes allows to customize the system starting from a few basic elements, in order to satisfy any design or installation need.

Metal grilles and circular air extraction valve, that are characterized by elegant and minimal design, complete the room air ductwork, while the round outdoor ventilation grilles protect the air inlet and air intake and air outlet ductings.

-  Supply Air
-  Fresh Air Inlet
-  Stale Air Extraction
-  Exhaust Air
-  Recirculation air

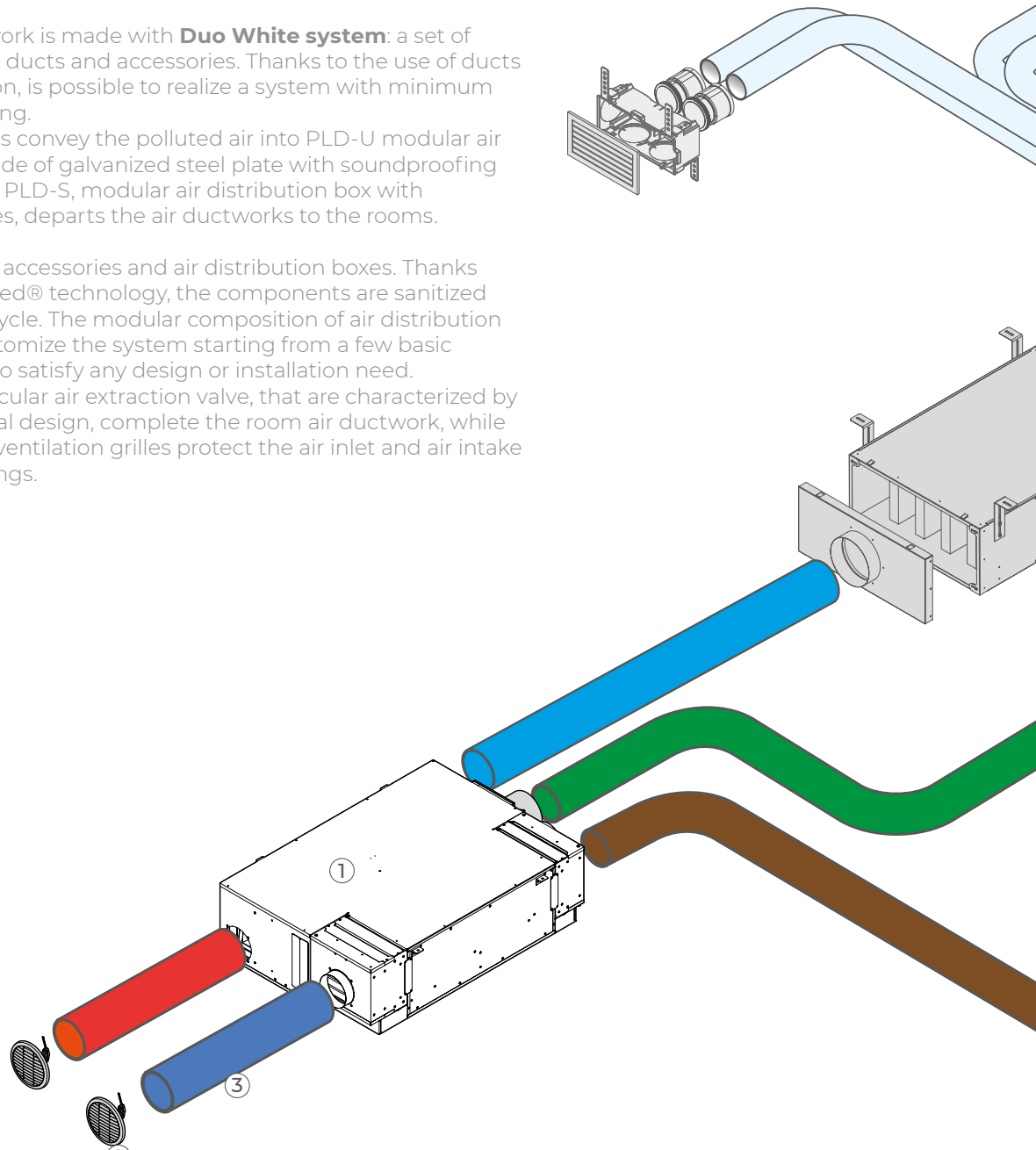

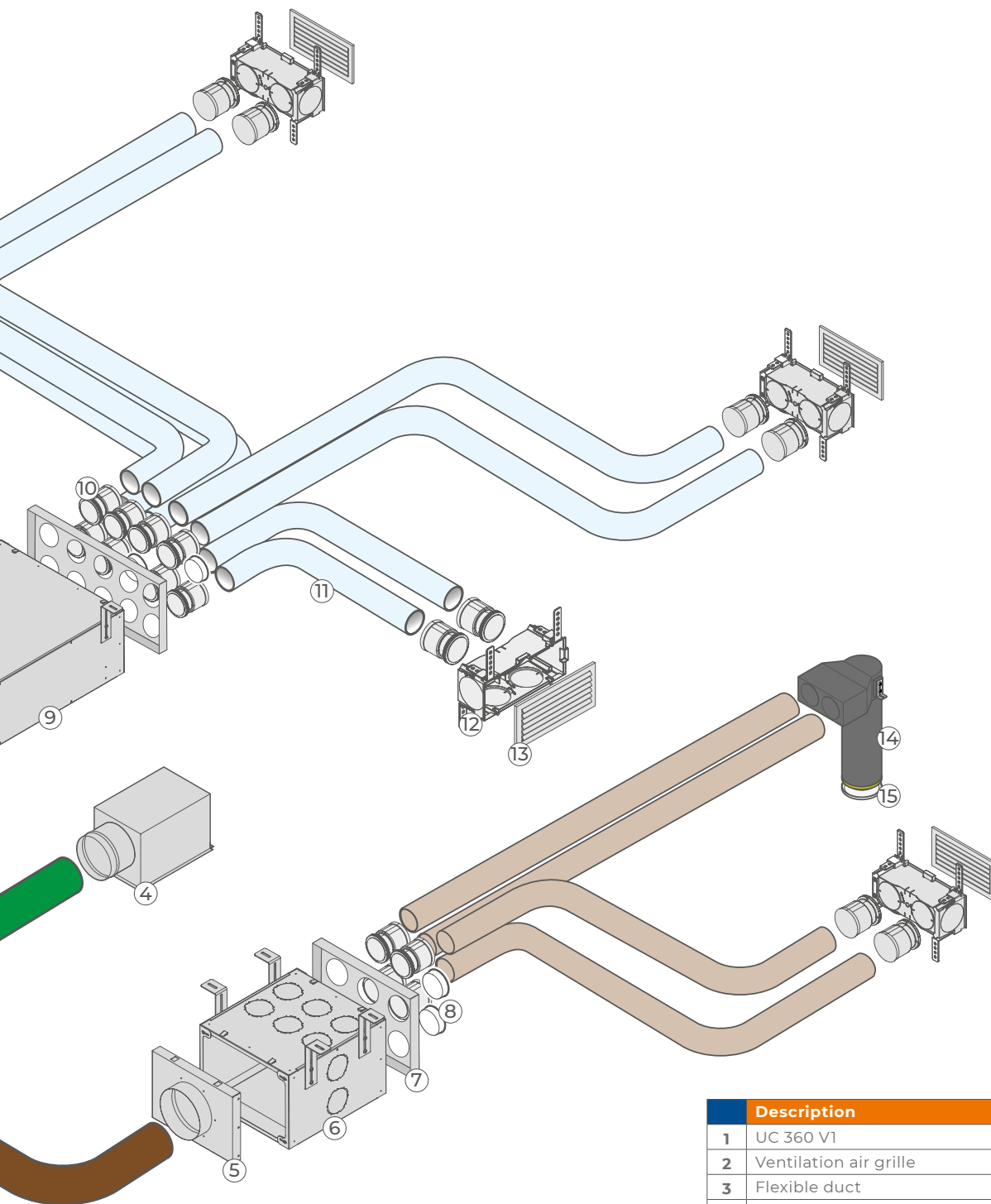

Description	
1	UC 360 V1
2	Ventilation air grille
3	Flexible duct
4	Air grille 400x100 mm
5	PLD-TC Cover with flared sleeve
6	PLD-U Universal distribution box
7	PLD-CD Cover for room air distribution
8	TPL Blanking cap
9	PLD-S Silenced distribution box
10	RDW connector
11	Duo White ducting
12	PLA 2 Room plenum
13	Room grille
14	Duo White circular room plenum
15	Extract air valve

SaniFLEX-termo Duct



Grey flexible duct made of polyolefin resin film with antibacterial and antimold additive. Integrated spring steel wire spiral. The duct is provided with thermal insulation in reinforced closed-cell expanded polyethylene and external protection with treated polyolefin resin film.

SIZE	PACK.	CODE
Ø 100 mm	10 m	7045360
Ø 125 mm	10 m	7045361
Ø 165 mm	10 m	7045364
Ø 200 mm	10 m	7045365

FEATURES

Colour	Gray
Working Temperature	-20 °C/+90 °C (+115 °C peak)
Curvature Radius	1.2 - 1.8 x Ø
Air Speed	max 20 m/s
Pressure	max 200 mm wc
Fire Reaction	Class B-s2, d0 (UNI EN 13501-1:2009)

PRESSURE DROP DIAGRAM (TEMPERATURE AIR 20°)

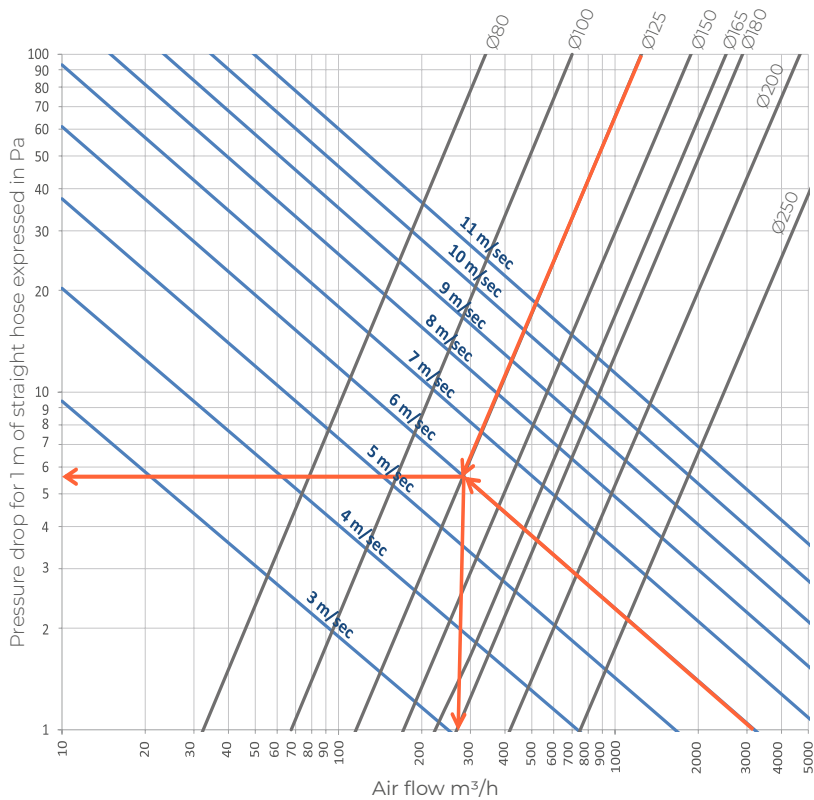



SaniFLEX-iso Duct

Insulated flexible duct made of polyolefin resin film with antibacterial and antimold additive. Equipped with spring steel wire spiral, thermal insulating layer in polyester fiber (thickness 25 mm, density 16 kg/m³) and external protection with aluminium film (flame retardant).

CERTIFICATIONS

Fire Reaction - Non-toxicity of fumes - Thermal insulation and sound absorption - Bacterial abatement certificate

SIZE	PACK.	CODE
Ø 100 mm	10 m	7045340
Ø 125 mm	10 m	7045341
Ø 160 mm	10 m	7045343
Ø 200 mm	10 m	7045344

FEATURES

Colour	Inner hose Grey - Sheath Aluminum
Working Temperature	-20°C/+90°C (+110°C peak))
Curvature Radius	0.8 - 1.5 x Ø
Air Speed	max 20 m/s
Pressure	max 200 mm wc
Fire Reaction	Internal Hose Class B-s1, d0 (EN 13823:2010) Thermo-Insulating Covering Class B-s2, d0 (UNI EN 13501-1:2009)

PRESSURE DROP DIAGRAM

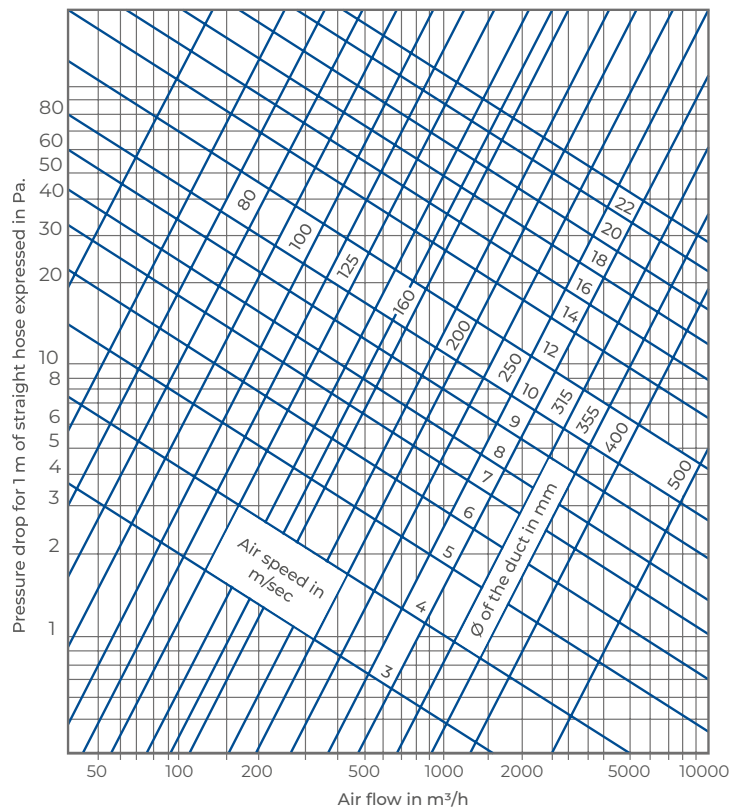

SaniFLEX Duct



Grey flexible duct made of polyolefin resin film with antibacterial and antimold additive. Integrated spring steel wire spiral.

CERTIFICATIONS
Fire Reaction - Non-toxicity of fumes - Bacterial abatement certificate

SIZE	PACK.	CODE
DN 100 mm	10 m	7045310
DN 125 mm	10 m	7045311
DN 160 mm	10 m	7045313
DN 200 mm	10 m	7045314

FEATURES

Colour	Gray
Working Temperature	-20 °C/+90 °C (+110 °C punte)
Curvature Radius	0.6 x Ø
Air Speed	max 20 m/s
Pressure	max 200 mm wc
Fire Reaction	ITALIAN CLASS: Class 1 (D.M. 26/06/84) EUROCLASS: Class B-s1, d0 (EN 13823:2010) FRENCH CLASS: Class M1 (AFNOR NF 92-507 § 3.1.2)

PRESSURE DROP DIAGRAM

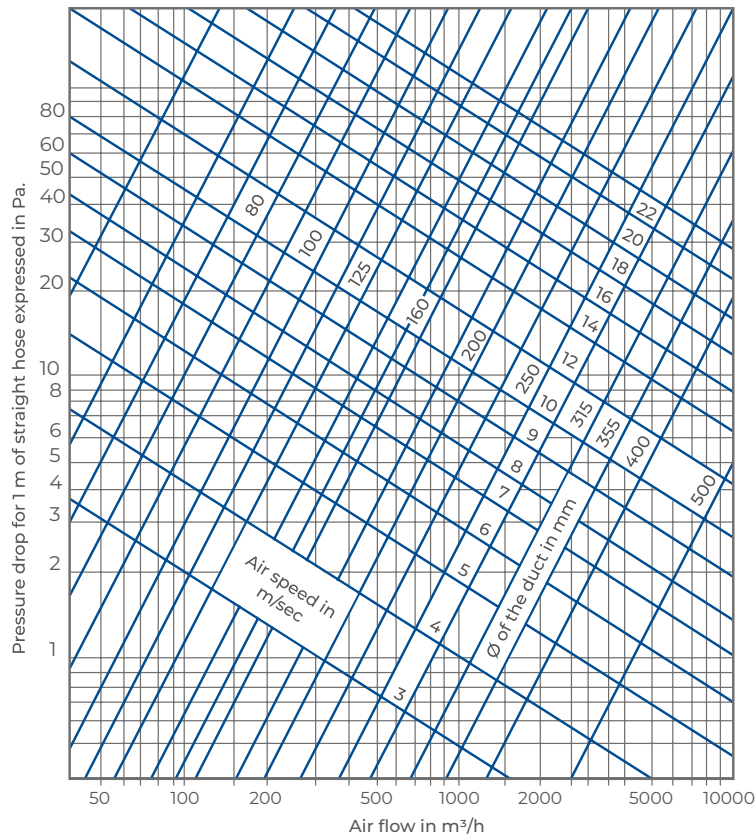

AluFLEX Acoustic Duct



Micro-perforated flexible insulated aluminium duct for air noise damping. Integrated spring steel wire spiral. The duct is provided with thermal insulation in polyester fiber (thickness 25 mm, density 16 kg/m³) and external protection with aluminium film (flame retardant).

SIZE	PACK.	CODE
DN 100 mm	10 m	7045370
DN 125 mm	10 m	7045371
DN 160 mm	10 m	7045373
DN 200 mm	10 m	7045374

CERTIFICATIONS

Fire Reaction - Thermal insulation and sound absorption

FEATURES

Colour	Gray
Working Temperature	-300 °C/+140 °C (+180 °C punte)
Curvature Radius	0.8 - 1.5 x Ø
Air Speed	max 32 m/s
Pressure	max 250 mm wc
Fire Reaction	ITALIAN CLASS: Class 1 (D.M. 26/06/84) EUROCLASS: Internal Hose Class B-s1, d0 (EN 13823:2010) Thermo-Insulating Covering Class B-s2, d0 (UNI EN 13501-1:2009)

PRESSURE DROP DIAGRAM

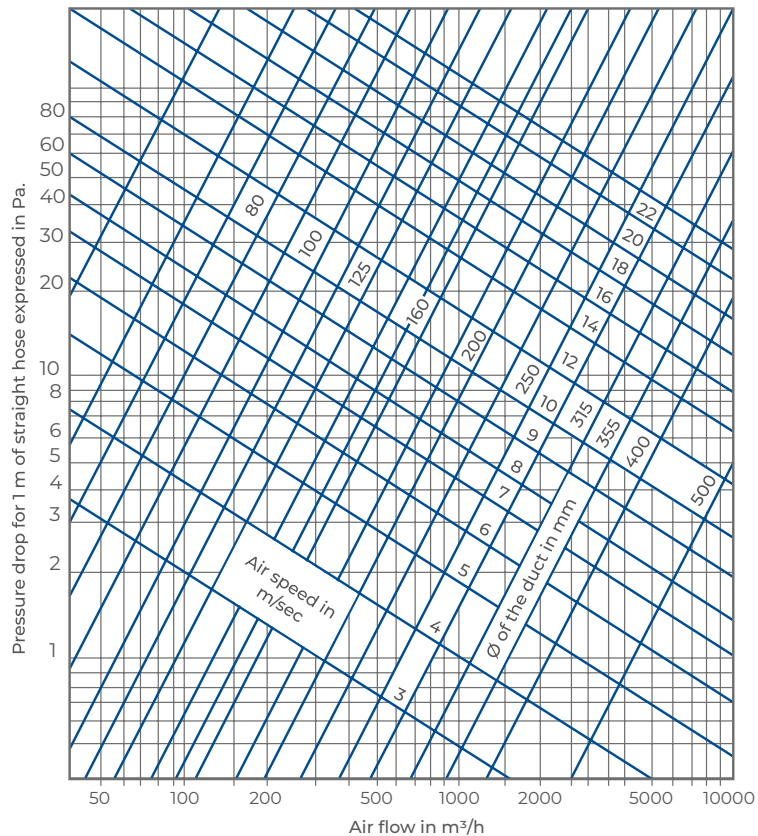



M/M Galvanized Coupling

Male coupling made of galvanized steel plate. Longitudinal electric welding and push-fit ends with EPDM double lip rubber seal. Air tightness class C.

SIZE	PACK.	CODE
Ø 100 mm	1 item	7045741
Ø 125 mm	1 item	7045742
Ø 150 mm	1 item	7045743
Ø 160 mm	1 item	7045744
Ø 200 mm	1 item	7045745



F/F Galvanized Coupling

Female coupling made of galvanized steel plate. Push-fit ends.

SIZE	PACK.	CODE
Ø 100 mm	1 item	7045055
Ø 125 mm	1 item	7045056
Ø 150 mm	1 item	7045057
Ø 160 mm	1 item	7045059
Ø 200 mm	1 item	7045058



M/M Galvanized reducer

Male reducer made of galvanized steel plate, including push-fit ends with EPDM double lip rubber seal. Air tightness class C.



SIZE (A)	SIZE (B)	PACK.	CODE
Ø 125 mm	Ø 100 mm	1 item	7045777
Ø 150 mm	Ø 100 mm	1 item	7045772
Ø 160 mm	Ø 100 mm	1 item	7045778
Ø 150 mm	Ø 125 mm	1 item	7045779
Ø 160 mm	Ø 125 mm	1 item	7045781
Ø 200 mm	Ø 100 mm	1 item	7045773
Ø 200 mm	Ø 125 mm	1 item	7045774
Ø 200 mm	Ø 150 mm	1 item	7045782
Ø 150 mm	Ø 160 mm	1 item	7045783
Ø 200 mm	Ø 160 mm	1 item	7045784



Galvanized Y-piece Connector

Y-piece 45° symmetrical connector made of galvanized steel plate, including push-fit ends with EPDM double lip rubber seal. Air tightness class C.

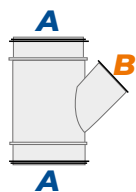

SIZE (A)	SIZE (B)	PACK.	CODE
Ø 100 mm	Ø 100 mm	1 item	7045806
Ø 125 mm	Ø 125 mm	1 item	7045808
Ø 125 mm	Ø 100 mm	1 item	7045809
Ø 160 mm	Ø 160 mm	1 item	7045813
Ø 160 mm	Ø 125 mm	1 item	7045814
Ø 200 mm	Ø 200 mm	1 item	7045815
Ø 200 mm	Ø 160 mm	1 item	7045817

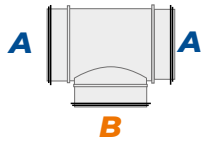

Galvanized T-piece Symmetrical connector

T-piece 90° symmetrical 3-way branch made of galvanized steel plate. Push-fit ends with EPDM double lip rubber seal. Air tightness class C.

SIZE (A)	SIZE (B)	PACK.	CODE
Ø 125 mm	Ø 125 mm	1 item	7045912
Ø 160 mm	Ø 160 mm	1 item	7045914
Ø 160 mm	Ø 125 mm	1 item	7045915
Ø 200 mm	Ø 200 mm	1 item	7045916
Ø 200 mm	Ø 160 mm	1 item	7045913

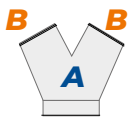

Y-Piece Symmetrical Connector - 90 Degree

Y-piece 90° symmetrical branch made of galvanized steel plate. Push-fit ends with EPDM double lip rubber seal. Air tightness class C.

SIZE (A)	SIZE (B)	PACK.	CODE
Ø 125 mm	Ø 100 mm	1 item	7045037
Ø 160 mm	Ø 125 mm	1 item	7045038
Ø 200 mm	Ø 125 mm	1 item	7045039



Galvanised Steel Fastening Strap

The flexible galvanized strap is used to fasten the air ducts on the floor or on the ceiling.

SIZE l x h	PACK.	CODE
12 mm x 0.8 m	10-m roll	7045061



Plastic Bands

Plastic bands to fix the flexible ducting.

SIZE l x h	PACK.	CODE
780 x 9 mm	20 items	7045010



Insulation Tape

The adhesive insulation strip is made of CFC-free extruded elastomer foam with closed-cell structure. Excellent dimensional stability. Size: height 50 mm, thickness 3 mm.

SIZE	PACK.	CODE
h 50 mm th. 3 mm	10-m roll	6512011



Self-Drilling Screw

The hexagonal head self-drilling screws are used to fix couplings and reducers. Size 4.8x19 mm.

SIZE l x h	PACK.	CODE
4.8x19 mm	25 items	7045015

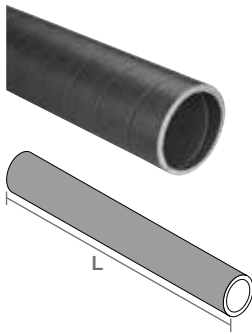

EPE Ducting

EPE ducting, insulating and sound-absorbing. It minimizes heat loss and prevents the formation of condensation. The smooth inner surface also reduces pressure loss. It is light, elastic and impact resistant. Length 2 m.

SIZE (Di)	SIZE (De)	L	PACK.	CODE
Ø 125 mm	Ø 157 mm	2 m	1 item	7046250
Ø 160 mm	Ø 192 mm	2 m	1 item	7046252
Ø 200 mm	Ø 232 mm	2 m	1 item	7046253



EPE 90° Bend

90° EPE insulating and sound-absorbing bend to circumvent obstacles or vary duct direction. It minimizes heat loss and prevents the formation of condensation. The smooth inner surface also reduces pressure loss.

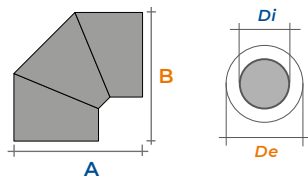

SIZE (Di)	SIZE (De)	SIZE (AxB)	PACK.	CODE
Ø 125 mm	Ø 157 mm	238x238 mm	1 item	7046255
Ø 160 mm	Ø 192 mm	274x274 mm	1 item	7046257
Ø 200 mm	Ø 232 mm	318x318 mm	1 item	7046258



EPE 45° Bend

45° EPE insulating and sound-absorbing bend to circumvent obstacles or vary duct direction. It minimizes heat loss and prevents the formation of condensation. The smooth inner surface also reduces pressure loss.

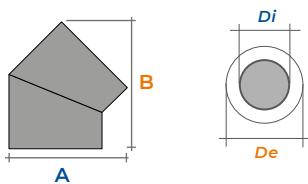

SIZE (Di)	SIZE (De)	SIZE (AxB)	PACK.	CODE
Ø 125 mm	Ø 157 mm	199x213 mm	1 item	7046260
Ø 160 mm	Ø 192 mm	235x239 mm	1 item	7046262
Ø 200 mm	Ø 232 mm	278x282 mm	1 item	7046263



EPE T-Connector

EPE T-piece, insulating and sound-absorbing. It minimizes heat loss and prevents the formation of condensation. The smooth inner surface also reduces pressure loss.

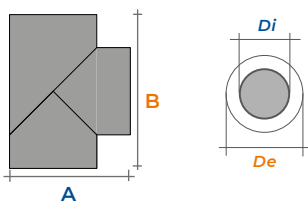

SIZE (Di)	SIZE (De)	SIZE (AxB)	PACK.	CODE
Ø 125 mm	Ø 157 mm	216x276 mm	1 item	7046265
Ø 160 mm	Ø 192 mm	254x316 mm	1 item	7046266



EPE Connector

It is used to connect bends and ducts made of EPE.

SIZE	PACK.	CODE
Ø 125 mm	1 item	7046270
Ø 160 mm	1 item	7046272
Ø 200 mm	1 item	7046263



EPE Hose Clip

Fixing clip for EPE ducting.

SIZE	PACK.	CODE
Ø 125 mm	1 item	7046275
Ø 160 mm	1 item	7046277
Ø 200 mm	1 item	7046278



PP Reducer

PP rigid reducer for EPE system to change Ø 160 mm into Ø 125 mm.

SIZE (A)	SIZE (B)	PACK.	CODE
Ø 160 mm	Ø 125 mm	1 item	7046245

SILENCERS



Rigid Circular Silencers

Attenuators for circular ducting made of aluminium (perforated in the internal duct) with sound-absorbing layer in high density glass wool, thickness 50 mm, non-flammable according to DIN EN 13501. Surface treated to avoid release of microfibers.

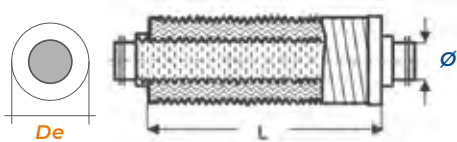

SIZE Ø	SIZE (De)	LENGHT	ΔLW	PACK.	CODE
Ø 125 mm	Ø 224 mm	500 mm	17.5 dB(A)	1 item	7045706
Ø 150 mm	Ø 224 mm	1000 mm	21.6 dB(A)	1 item	7045707
Ø 160 mm	Ø 250 mm	500 mm	14.3 dB(A)	1 item	7046012
Ø 160 mm	Ø 250 mm	1000 mm	19.2 dB(A)	1 item	7046013
Ø 200 mm	Ø 300 mm	500 mm	14.3 dB(A)	1 item	7045702
Ø 200 mm	Ø 300 mm	1000 mm	19.2 dB(A)	1 item	7045703

Duo White Ducting



Flexible ducting made of high-density double-walled polyethylene, corrugated outside and smooth inside, specific for air distribution systems. The use of Sanitized® technology ensures the ducting remains disinfected for its entire operating life.

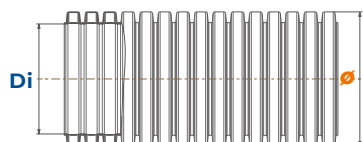

SIZE Ø	SIZE (Di)	PACK.	CODE
75 mm	63 mm	50 m	7045091
90 mm	76 mm	50 m	7045092

DUO WHITE THERMO Ducting



Double-wall high-density polyethylene hose, corrugated on the outside and smooth on the inside, specifically for air distribution systems. Thanks to the use of Sanitized® technology, the pipe is sanitised throughout its entire life cycle. It is supplied pre-insulated with 4 mm closed cell insulation.

SIZE Ø	SIZE (Di)	PACK.	CODE
75 mm	63 mm	50 m	7045095
90 mm	76 mm	50 m	7045096

Technical characteristics		DUO WHITE		DUO WHITE THERMO	
Characteristic	U.M.	Ø 75	Ø 90	Ø 75	Ø 90
Inside diameter	mm	63	76	63	76
Outside diameter		75	90	75	90
Total outside diameter		-	-	83	98
Insulating sheath thickness	mm	--		4	
Thermal conductivity	W/(K · m)	--		0.039	
Inside Layer		Antibacterial Antifungal Antistatic			
Internal Ripple		< 50%			
Weight	gr/m	250	340	280	376

Pressure drops				
Characteristic		U.M.	Ø 75	Ø 90
Crush resistance		N	>450	>450
Radius of curvature		mm	225	270
Air velocity 2 m/s		m ³ /h	22.44	32.66
Pressure drop 2 m/s	Straight pipe (1 m)	Pa	1.04	0.99
	90° bend		0.79	0.87
	180° elbow		1.30	1.32
Air velocity 2.5 m/s		m ³ /h	28.06	40.83
Pressure drop 2.5 m/s	Straight pipe (1 m)	Pa	1.62	1.54
	90° bend		1.24	1.35
	180° elbow ^o		2.03	2.07
Air velocity 3 m/s		m ³ /h	33.67	48.99
Pressure drop 3 m/s	Straight pipe (1 m)	Pa	2.33	2.22
	90° bend		1.79	1.95
	180° elbow		2.93	2.98

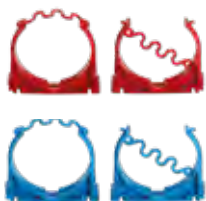

Duo White Clip

Plastic fixing clips for Duo White ducting.

SIZE	COLOUR	PACK.	CODE
Ø 75 mm	red	48 pezzi	7045161
Ø 75 mm	blue	48 pezzi	7045162
Ø 90 mm	red	48 pezzi	7045164
Ø 90 mm	blue	48 pezzi	7045165



Duo White Connector

Polyethylene fitting for connecting Duo White ducting.

SIZE	PACK.	CODE
Ø 75 mm	1 item	7045168
Ø 90 mm	1 item	7045169



Duo White Cap

Closing cap for Duo White ducting.

SIZE	PACK.	CODE
Ø 75 mm	1 item	7045181
Ø 90 mm	1 item	7045182



Duo White Bend

90° bend FF made of high-density PE to avoid obstacles or change the direction of the ducting from horizontal to vertical. It can be cut on one side for the connection with F components.

SIZE	PACK.	CODE
Ø 75 mm	1 item	7045188
Ø 90 mm	1 item	7045189

Duo White Gasket

Rubber gasket to ensure airtight seal.



SIZE	PACK.	CODE
Ø 75 mm	1 item	7045186
Ø 90 mm	1 item	7045187

MODULAR AIR DISTRIBUTION BOX

PLD is a modular air distribution box for the Duo White system. Thanks to its composition it can be customized starting from a few elementary elements, in order to satisfy any design or installation need.

Componenti:

- PLD-U:** universal distribution box
- PLD-S:** silenced distribution box
- PLD-TC:** cover with flared sleeve
- PLD-CD:** cover for room air distribution
- PLD-T:** closing plate
- RDW:** fitting for the connection of Duo White duct to the distribution box
- TPL:** blanking cap for closing the unused outlets
- PLD-KR:** fitting kit

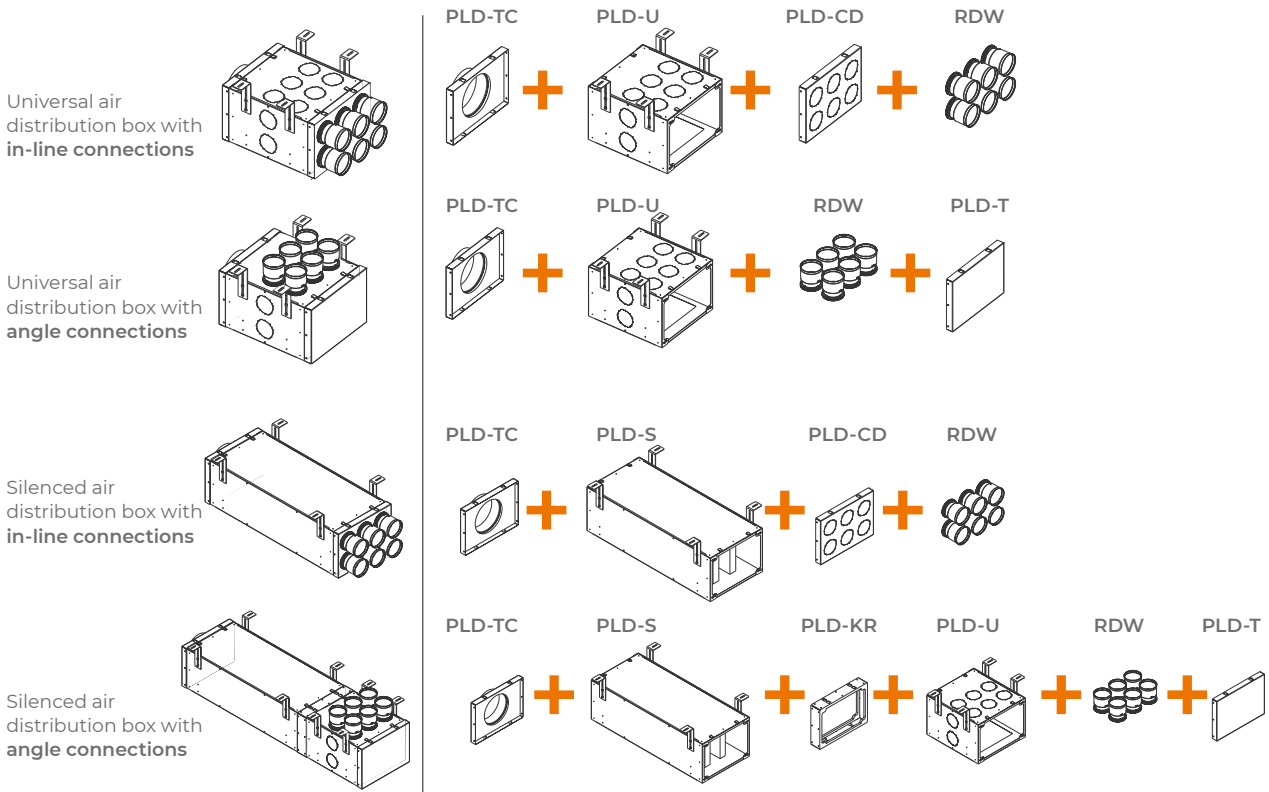

PLD-U



Universal modular distribution box with inspection hatch. Central body in galvanised sheet metal.
 Soundproofing internal insulation made of open-cell polyurethane. Prepared for connection of the pipes on the upper and lateral side.
 Available with 6 or 10 connections (OUT).

NAME	SIZE hxlxp	OUTLETS	PACK.	CODE
PLD-U 6	230x320x350 mm	6	1 item	7046460
PLD-U 10	230x520x350 mm	10	1 item	7046461

PERFORMANCE

Plenum PLD-U - Supply air

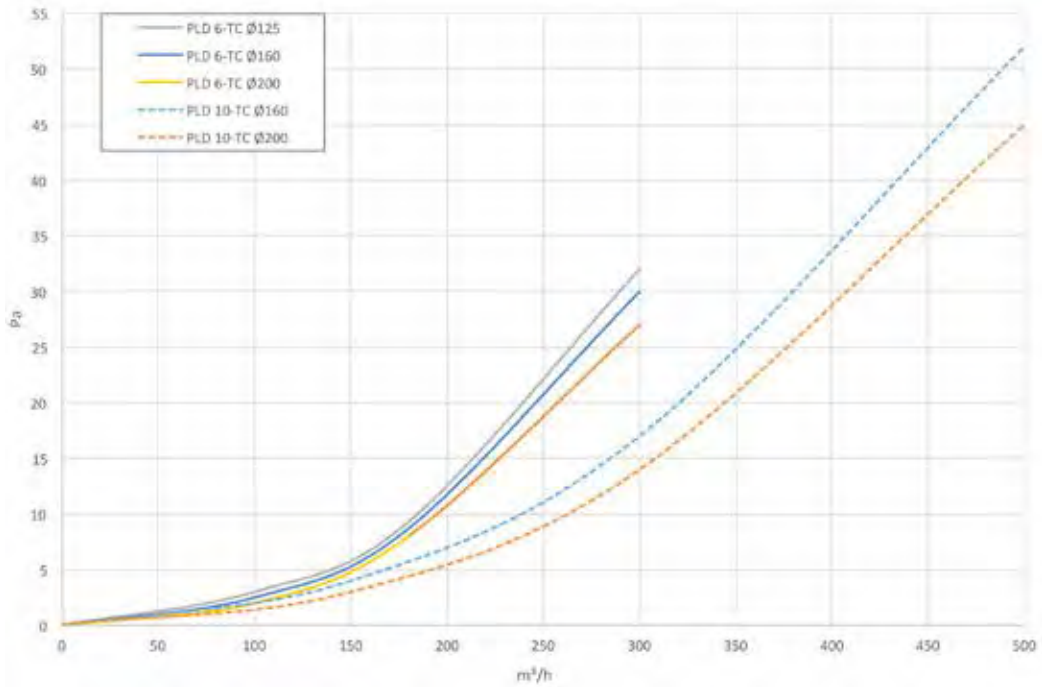

Plenum PLD-U - Stale air extraction

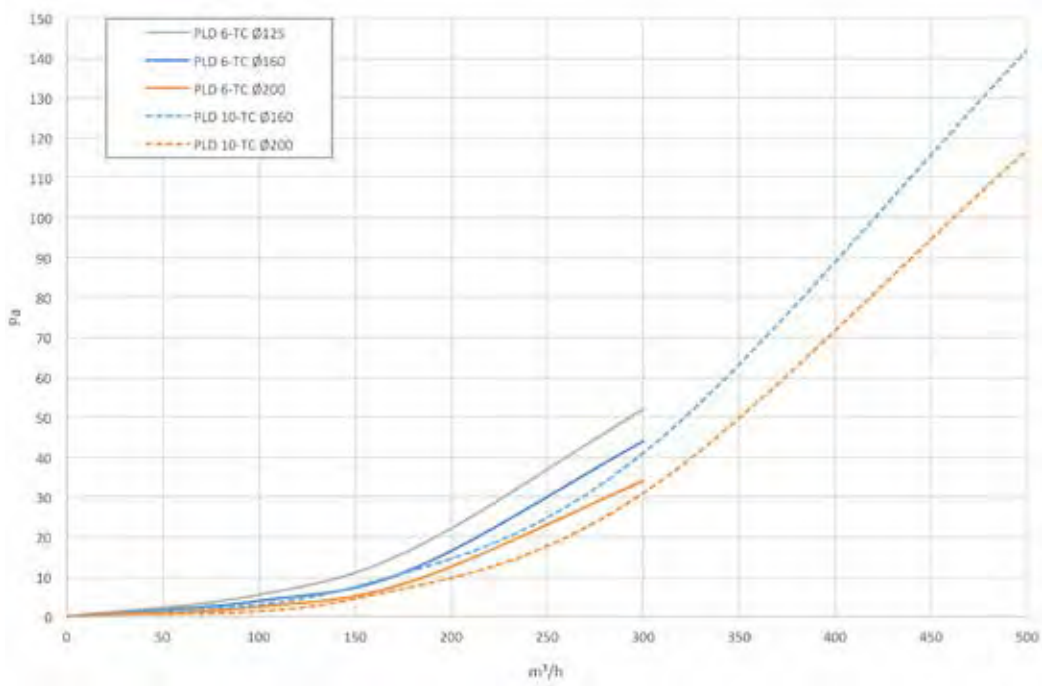

PLD-S



Modular distribution box with sound-absorbing baffles and inspection door. Central body of the plenum in galva-nised sheet metal. Internal soundproofing in open cell polyurethane + high density polyester. Available with 6 and 10 connections (OUT).

NAME	SIZE hxlxp	OUTLETS	PACK.	CODE
PLD-S 6	230x320x750 mm	6	1 item	7046465
PLD-S 10	230x520x750 mm	10	1 item	7046466

PERFORMANCE

Plenum PLD-S - Supply air

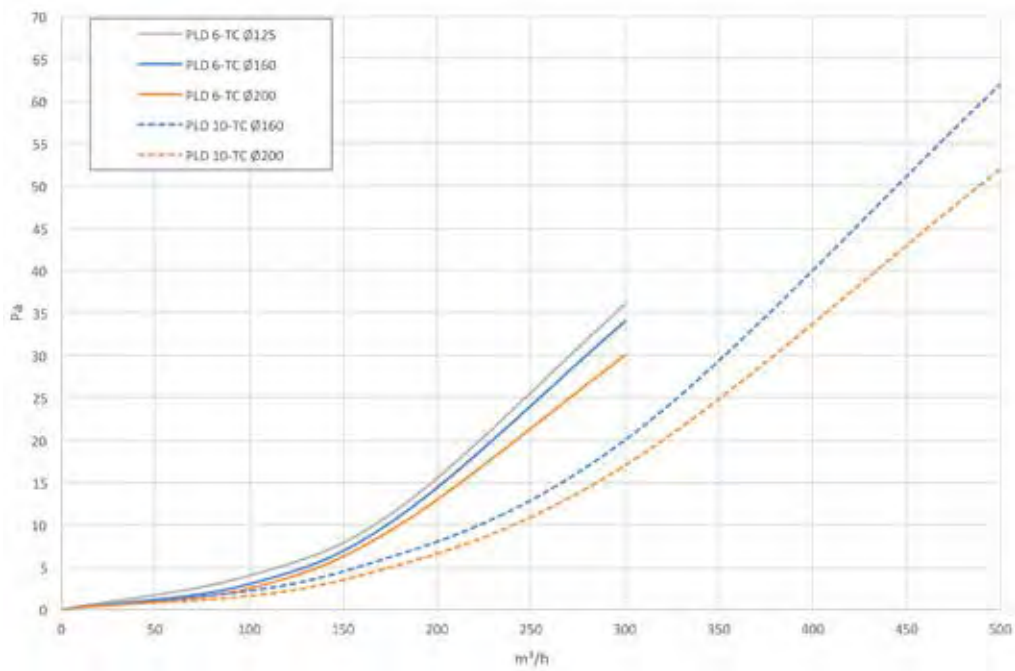

Plenum PLD-S - Stale air extraction

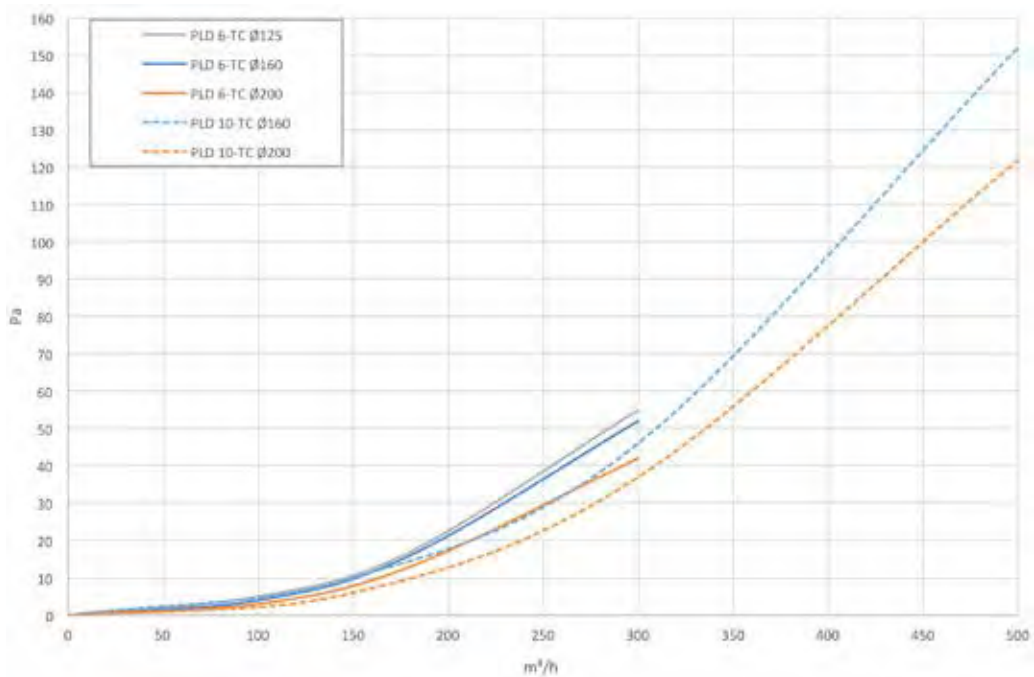

Silenced plenum sound attenuation

m ³ /h	mod.	125 Hz	250 Hz	500 Hz	1000 Hz	2000 Hz	4000 Hz	8000 Hz	DL _{aeq} [dBA]
300	PLD-S 6	0.0	0.1	1.9	7.5	18.0	19.0	21.0	5.7
	PLD-S 10	0.0	0.0	2.9	9.1	23.5	22.0	34.7	6.0
450	PLD-S 10	0.0	0.0	2.6	9.2	19.7	20.1	22.3	6.9

PLD-TC



Cover for PLD distribution box with sleeve for primary air pipe connection. Sound-absorbing internal insulation made of open-cell polyurethane.

NAME	SIZE Ø	SIZE hxl	PACK.	CODE
PLD 6-TC 125	125 mm	230x320 mm	1 item	7046450
PLD 6-TC 160	160 mm	230x320 mm	1 item	7046451
PLD 6-TC 200	200 mm	230x320 mm	1 item	7046452
PLD 10-TC 160	160 mm	230x520 mm	1 item	7046453
PLD 10-TC 200	200 mm	230x520 mm	1 item	7046454

PLD-CD



Cover for PLD distribution box with connections for secondary air ducts using RDW fittings. Sound-absorbing internal insulation made of open-cell polyurethane.

NAME	OUTLETS	SIZE hxl	PACK.	CODE
PLD-CD 6	6	230x320 mm	1 item	7046455
PLD-CD 10	10	230x520 mm	1 item	7046456

PLD-T



Closing cover for PLD distribution box. Sound-absorbing internal insulation made of open-cell polyurethane.

NAME	SIZE hxl	PACK.	CODE
PLD-T 6	230x320 mm	1 item	7046457
PLD-T 10	230x520 mm	1 item	7046458

RDW



Fitting for connecting Duo White pipe to the room plenum and distribution box.

NAME	SIZE Ø	PACK.	CODE
RDW 75	75 mm	2 items	7046441
RDW 90	90 mm	2 items	7046442

TPL



Cap for distribution box or room plenum to close unused or incorrectly opened distribution cover branches.

NAME	PACK.	CODE
TPL	1 item	7046445

PLD-KR



Connection kit for joining PLD-U and PLD-S boxes.

NAME	PACK.	CODE
PLD-KR 6	1 item	7046468
PLD-KR 10	1 item	7046469

PLD-F



Module for housing F7 or F9 filters to be installed on the room outlet to increase the filtration degree of the system. Designed to house a single filter in the PLD-F 6 version and two filters side by side in the PLD-F 10 version. Can be coupled to PLD distribution plenums or installed separately.

NAME	FILTERS	SIZE hxl	PACK.	CODE
PLD-F 6	1	320x230x250 mm	1 item	7046410
PLD-F10	2	520x230x250 mm	1 item	7046411

PLD-F F7



ISO ePM1 60% (F7) filter - 217X238X47 mm

PLD-F F9

ISO ePM1 80% (F9) filter - 217X238X97 mm

NAME	PACK.	CODE
PLD-F F7	1 item	7046415
PLD-F F9	1 item	7046416

Filtration box PLD-F

· The PLD-F sheet metal box is designed to be placed downstream of the air handling unit and has the following advantages

- it is detached from the machine
- can accommodate F7 or F9 filters
- it is compatible with ducting of different diameters
- has an 'easy' opening/closing system

Application examples

PLD-F coupled to the distribution plenum

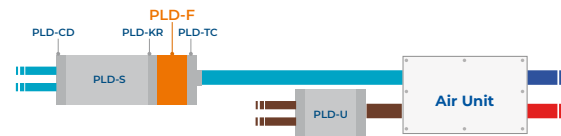

PLD-F coupled to the distribution plenum

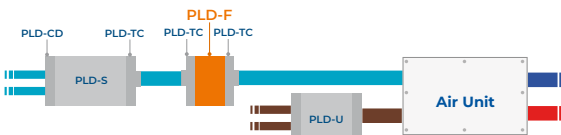

PLD-F with accessory for connection to 2 delivery plenums

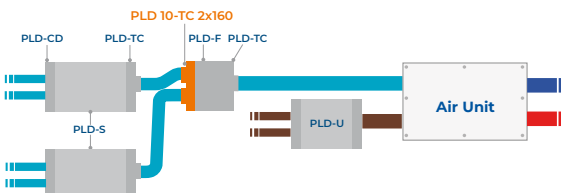

ROOM PLENUM FOR DUO WHITE SYSTEM

Duo White circular room plenum

Wall or ceiling circular room plenum, made of PP, DN125, for air distribution systems with two Duo White DN75 duct connections. It is equipped with closing cap for any unused spigots.



SIZE Ø	VERSION	PACK.	CODE
75 mm	long	1 item	7045195
90 mm	long	1 item	7045196
75 mm	short	1 item	7045198
90 mm	short	1 item	7045199

Description	Version	D_A	D_I	L/L_1	I	$A/A_1/A_2$	Material	Weight
		[mm]						[Kg]
2xDN 75 / DN 125 mm	Long	130	125	191/205	180	383 / 86 / 297	PP	0,91
2xDN 90 / DN 125 mm		130	125	197/210	210	400 / 103 / 297		1,03
2xDN 75 / DN 125 mm	Short	130	125	191/205	180	150 / 86 / 64		0,47
2xDN 90 / DN 125 mm		130	125	197/210	210	167 / 103 / 64		0,75

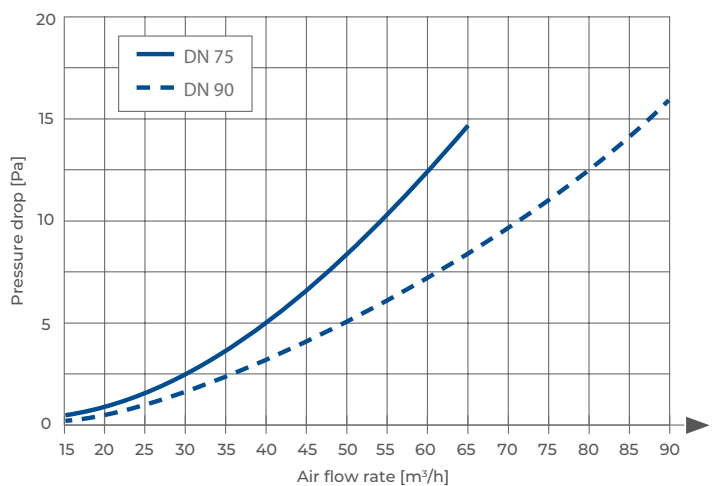
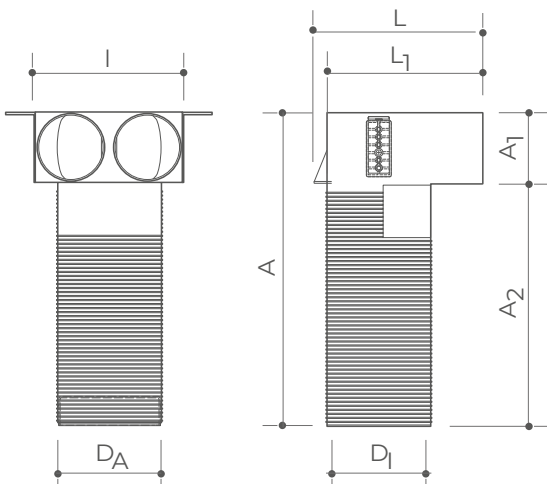



PLA 1

Room plenum in ABS, swivelling for the connection of DN 75 or DN 90 flexible pipe. Single side outlet possible.

Recessed depth adaptable by means of adjustable brackets.

Supplied with:

- ABS Brackets for wall mounting
- Levels for correct alignment
- Sealed protective cover
- Protective polystyrene for plastering

NAME	N. OUTLETS	PACK.	CODE
PLA1	1	1 item	7046430



PLA 2

Room plenum in ABS with 2 outlets, swivelling for the connection of DN 75 or DN 90 flexible pipes.

Possibility of a 1 outlet from the side, 2 from the rear, 2 from the bottom or 2 from the top. Recessed depth adaptable by means of adjustable brackets.

Supplied with:

- 4 end caps for unused outlets
- ABS Brackets for wall mounting
- Levels for correct alignment
- Sealed protective cover
- Protective polystyrene for plastering

NAME	N. OUTLETS	PACK.	CODE
PLA 2	2	1 item	7046431

PERFORMANCE

PLA - Supply air

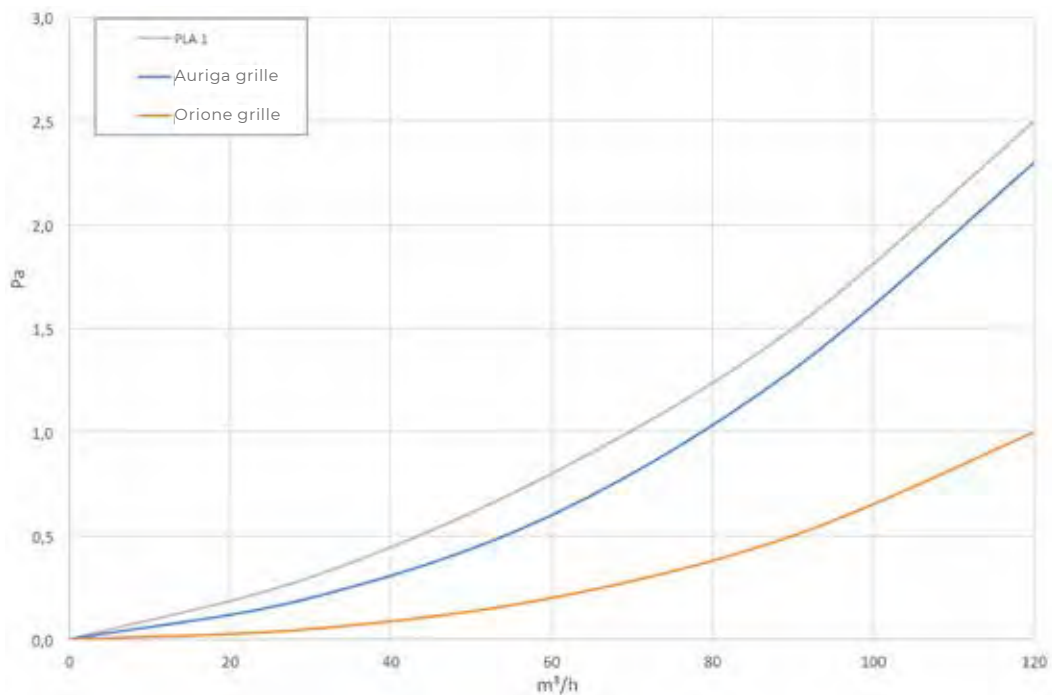

PLA - Stale air extraction

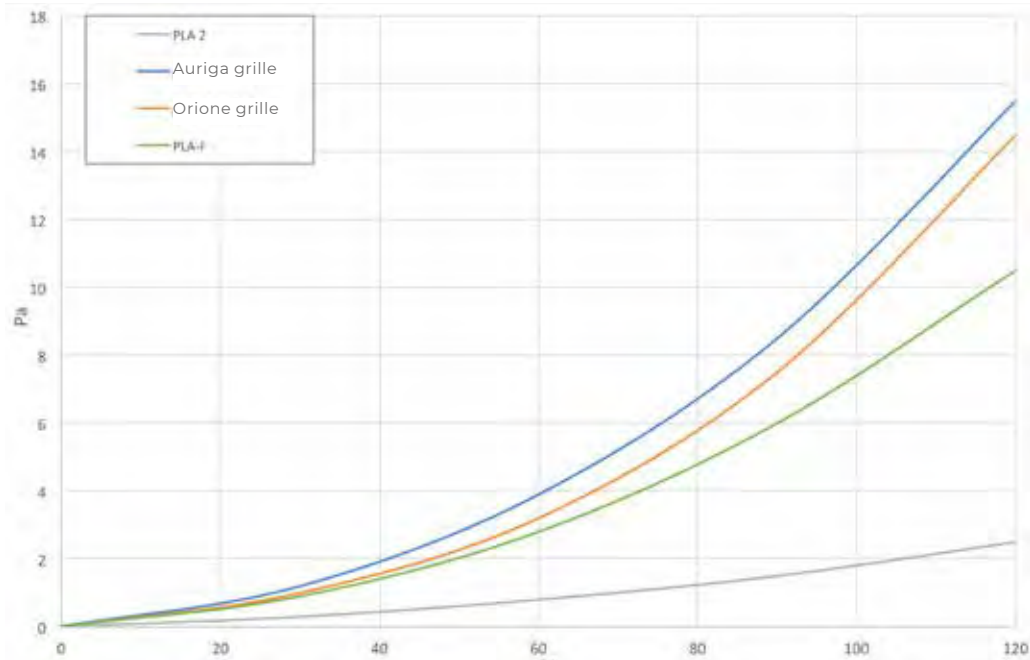

RDW



Fitting for connecting Duo White ducts to room plenum and distribution box.

NAME	SIZE Ø	PACK.	CODE
RDW 75	75 mm	2 items	7046441
RDW 90	90 mm	2 items	7046442

PLA-REG



Accessory for PLA series plenum boxes. Allows flow rate adjustment by removing concentric sectors.

NAME	SIZE Ø	PACK.	CODE
PLA-REG	70 mm	10 items	7046444

Flow rate reduction				
-20 %	-30 %	-40 %	-50 %	-60 %
All elements removed	3 elements removed	2 elements removed	1 element removed	No elements removed

PLA-F

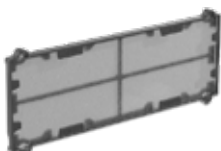

Polyester filter on ABS structure. Accessory for PLA series room plenum. Snap-in assembly.

NOME	PACK.	CODE
PLA-F	10 items	7046420

LINEAR AIR DIFFUSER



PLA-FLOW

Hidden linear ceiling or high wall diffuser designed for efficient air distribution. Used for both air supply and return, it is made of galvanised sheet metal and designed to be fully integrated into the false ceiling.

- Installation on ceiling
- Airflow rate adjustment
- Maximum flow rate 150 mc/h
- 3 filters (optional) in supply line to be ordered separately

pre-arranged connections:

- 3 x Duo White 75/90
- 2 x Dn 100
- 1 x Dn 125

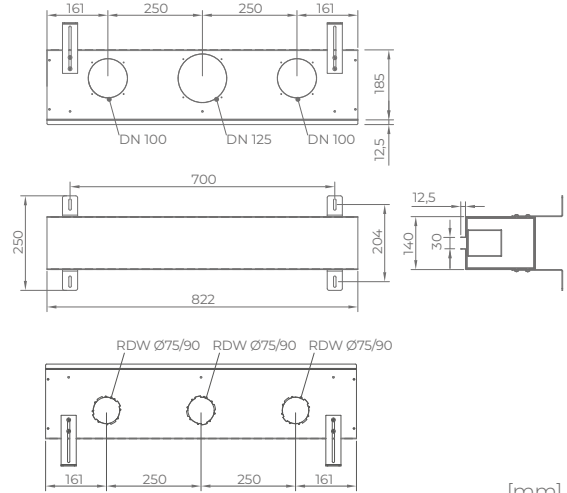

[mm]

NAME	SIZE LXHXD	PACK.	CODE
PLA-FLOW	822x198x140 mm	1 item	7046433

PRESSURE DROP

Inlet/outlet air speed (100% opening)

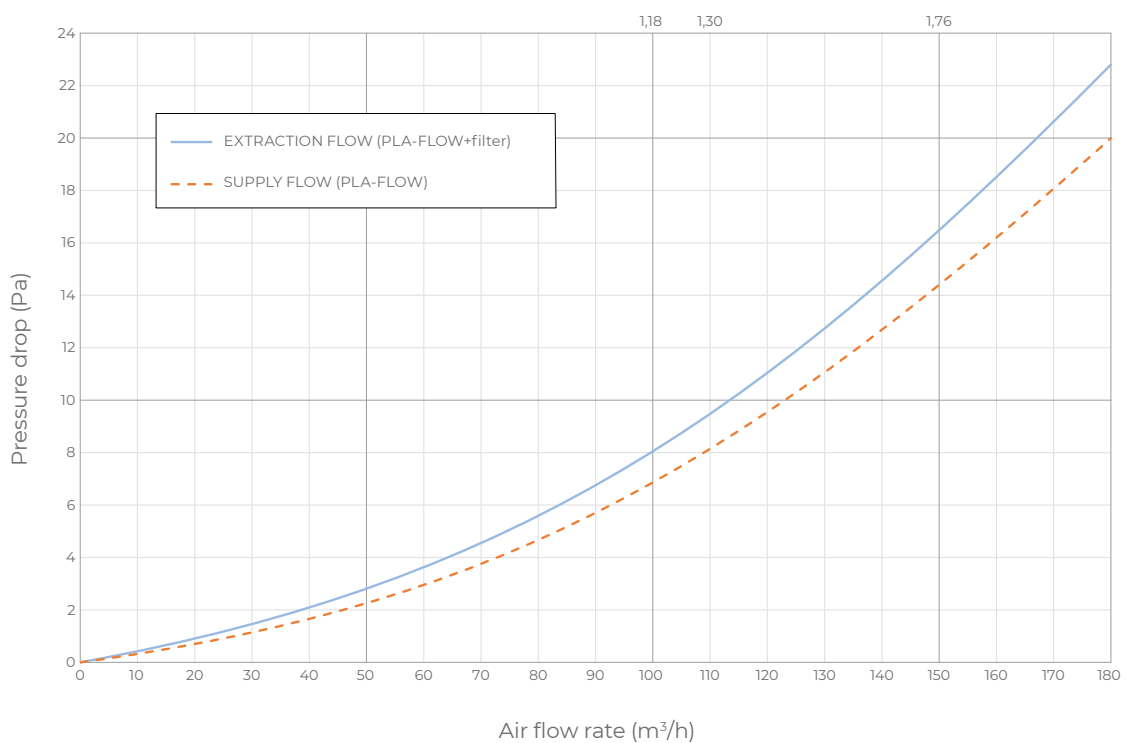



PLA-80

Ceiling or wall linear diffuser that has been designed for efficient air distribution. Used both for supply and return, it is made of galvanised sheet metal internally insulated and equipped with an aluminium grille.

- Ceiling or wall installation
- Airflow rate adjustment
- Maximum flow rate 150 mc/h
- 3 filters (optional)

pre-arranged connections:

- 5 x Duo White 75/90
- 3 x Dn 100
- 1 x Dn 125

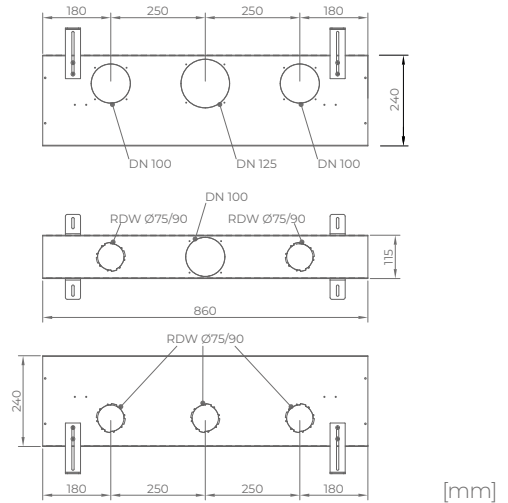

NAME	SIZE LXHXD	PACK.	CODE
PLA-80	860x240x115 mm	1 item	7046434

■ ■ PRESSURE DROP

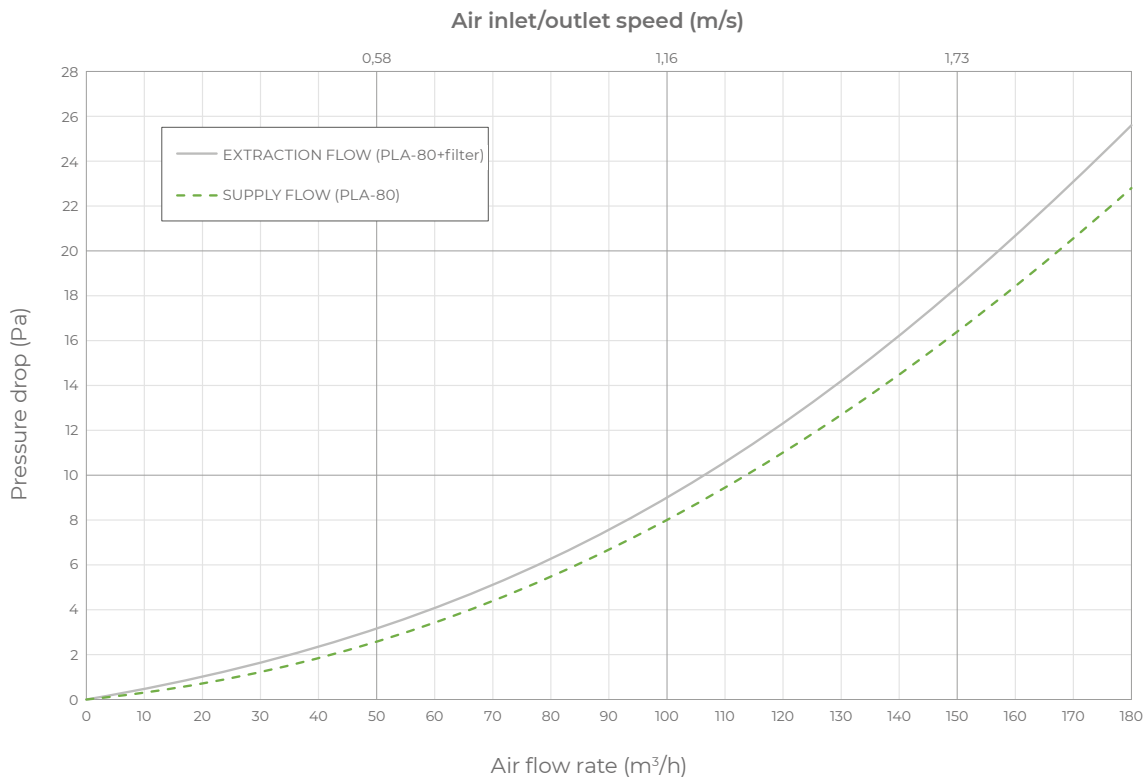

■ VENTILATION AIR GRILLES FOR DUO WHITE



Vega

ABS plastic diffuser with smooth white RAL 9010 paintable finish designed to match PLA room nozzles. Rapid pressure fixing. Can be used for both supply and extract of room air.

FINISHING	SIZE lxhxp	PACK.	CODE
white Ral 9010	300x130x8 mm	1 item	7046486



Auriga

Metal grille for PLA room plenums and quick fastening by pressure. Stainless steel finishing with Ø 5 mm round pattern design.

FINISHING	SIZE lxhxp	PACK.	CODE
inox	300x130x8 mm	1 item	7046480
white Ral 9010	300x130x8 mm	1 item	7046481



Orione

Metal grille for PLA room plenums and quick fastening by pressure. Stainless steel finishing with horizontal blades design.

FINISHING	SIZE lxhxp	PACK.	CODE
inox	300x130x8 mm	1 item	7046484
white Ral 9010	300x130x8 mm	1 item	7046485



Pegaso

Metal grille for PLA room plenums and quick fastening by pressure. Stainless steel finishing with vertical blades design.

FINISHING	SIZE lxhxp	PACK.	CODE
inox	300x130x8 mm	1 item	7046482
white Ral 9010	300x130x8 mm	1 item	7046483



LowAir Duct

Flexible ducting in PP with semi-oval section, specific for air distribution systems. It is double-walled, corrugated outside and smooth inside to minimize pressure losses and ensure long-term cleanliness. Characterized by easy installation, it has good antistatic and antibacterial properties.

SIZE	PACK.	CODE
50x102 mm	50 m	7046101

	LowAir	LowAir horizontal	LowAir vertical
			
Radius [mm]	-	$r1 > 200$	$r2 > 150$
Zeta [-]	-	0,24 (r=200)	0,60 (r=150)
Qv [m³/h]	Δp [Pa]	Δp [Pa]	Δp [Pa]
10	0,3	0,1	0,3
20	1,2	0,5	1,2
30	2,8	1,1	2,6
40	4,9	1,9	4,7
50	7,7	2,9	7,3
60	11,1	4,2	10,6



LowAir Duct Connector

Antistatic and antibacterial coupler for straight connection of flat ducting. Suitable for ceiling or wall installation, it is easy to assemble with sealing ring gasket.

SIZE	PACK.	CODE
50x102 mm	1 item	7046105



LowAir Duct Ring

Ring made of composite PP and TPE material for sealing connections between flat ducting. Its high flexibility makes installation easier and ensures airtight connections.

To be used with:

- LowAir connector
- LowAir horizontal bend
- LowAir vertical bend
- LowAir DW Ø75 adapter

PACK.	CODE
10 items	7046110



Cap for LowAir Connectors and Plenum

Antistatic and antibacterial closing cap for unused plenum spigots (102x50 mm).

SIZE	PACK.	CODE
50x102 mm	1 item	7046115



LowAir Horizontal Bend

Antistatic and antibacterial PP bend with minimum pressure loss. It is suitable for wall, floor, and ceiling installation, and it is used to avoid obstacles.

SIZE	PACK.	CODE
50x102 mm	1 item	7046125

Zeta [-]	0,23
Qv [m³/h]	Δp [Pa]
10	0,1
20	0,5
30	1,0
40	1,8
50	2,9
60	4,1

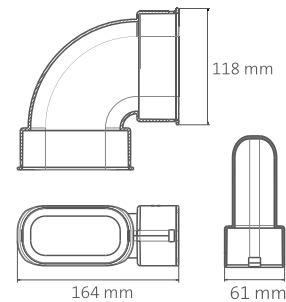

LowAir Vertical Bend

Antistatic and antibacterial PP bend with minimum pressure loss. It is suitable for wall, floor, and ceiling installation, and it is used to avoid obstacles or to make the ducts change from horizontal to vertical direction.

SIZE	PACK.	CODE
50x102 mm	1 item	7046120

Zeta [-]	0,55
Qv [m³/h]	Δp [Pa]
10	0,3
20	1,1
30	2,5
40	4,4
50	6,9
60	9,9

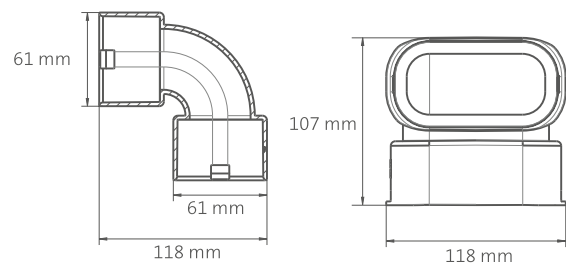

LowAir Clip

PP fixing brackets to ensure stability for LowAir ducting. The brackets can be connected together for the installation of parallel ducts.





SIZE	PACK.	CODE
50x102 mm	10 items	7046130



LowAir Flow Regulator

PP ring for air flow regulation.

SIZE	PACK.	CODE
50x102 mm	10 items	7046135

Number of rings removed					
	0	1	2	3	4
					
Zeta [-]	19,32	5,18	1,52	0,45	0,23
ΔP [Pa]					
10 m ³ /h	9,5	2,5	0,7	0,2	0,1
20 m ³ /h	37,8	10,1	3,0	0,9	0,5
30 m ³ /h	85,1	22,8	6,7	2,0	1,0
40 m ³ /h	151,3	40,6	11,9	3,5	1,8
50 m ³ /h	236,3	63,4	18,6	5,5	2,8
60 m ³ /h	340,3	91,2	26,8	7,9	4,1



Cap for LowAir Ducting

This closure cap for LowAir ducting can be used on preinstalled systems.

SIZE	PACK.	CODE
50x102 mm	1 item	7046116



LowAir DW Ø75 Adapter

LowAir hose adapters, made of antistatic and antibacterial PP, for the connection to DuoWhite 75 pipe.

SIZE Ø	PACK.	CODE
75 mm	10 items	7046213



Ring for LowAir Adapter

PP ring for hermetic sealing of the LowAir system used to make mechanical connections between ducts, accessories and distribution box.

SIZE Ø	PACK.	CODE
75 mm	10 items	7046221



LowAir air distribution box with in-line connections

Supply or exhaust air distribution box made of pre-painted white galvanized steel plate, insulated with high-performance soundproofing and anechoic material. It is equipped with pre-painted galvanized steel connection plate and connectors for the LowAir system. Nominal air flow rate up to 500 m³/h.

SIZE IN Ø	SIZE l x h x d	N. OUTLETS	PACK.	CODE
125 mm	282x236x543 mm	4	1 item	70PM0125L0004
125 mm	562x236x543 mm	8	1 item	70PM0125L0008
160 mm	282x236x543 mm	4	1 item	70PM0160L0004
160 mm	562x236x543 mm	8	1 item	70PM0160L0008
160 mm	842x236x543 mm	12	1 item	70PM0160L0012
200 mm	562x236x543 mm	8	1 item	70PM0200L0008
200 mm	842x236x543 mm	12	1 item	70PM0200L0012

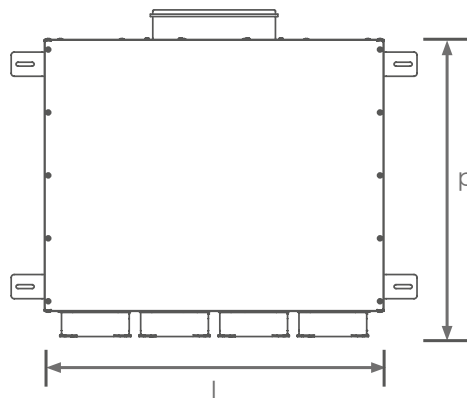
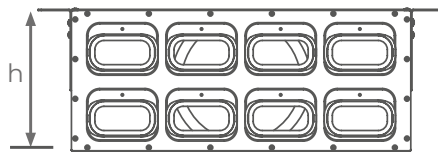

LowAir air distribution box with angle connections

Supply or exhaust air distribution box made of pre-painted white galvanized steel plate, insulated with high-performance soundproofing and anechoic material. It is equipped with pre-painted galvanized steel connection plate and connectors for the LowAir system. Nominal air flow rate up to 500 m³/h.



SIZE IN Ø	SIZE l x h x d	N. OUTLETS	PACK.	CODE
125 mm	282x280x503 mm	4	1 item	70PM0125S0004
125 mm	562x280x503 mm	8	1 item	70PM0125S0008
160 mm	282x280x503 mm	4	1 item	70PM0160S0004
160 mm	562x280x503 mm	8	1 item	70PM0160S0008
160 mm	842x280x503 mm	12	1 item	70PM0160S0012
200 mm	562x280x503 mm	8	1 item	70PM0200S0008
200 mm	842x280x503 mm	12	1 item	70PM0200S0012

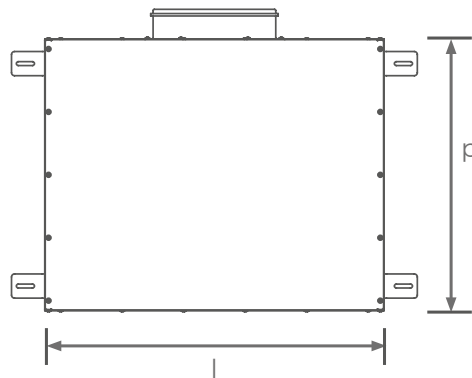
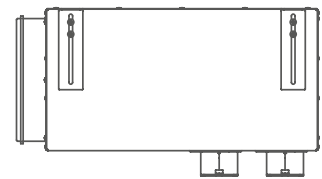
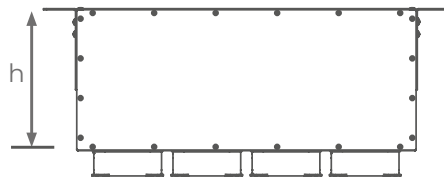



LowAir Circular Plenum

Circular room plenum in antistatic and antibacterial PP Ø 125 mm for air distribution systems. Designed for ceiling or wall installation, it is equipped with two spigots for flat ducting (102x50 mm) with suitable ring. It is supplied as standard with dust cover on the valve connection (DN125) and removable cap.



SIZE Ø	PACK.	CODE
125 mm	1 item	7046140

PLA C-F	PACK.	CODE
Filter for room plenum	10 items	7045197

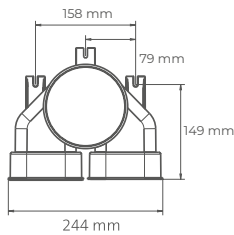
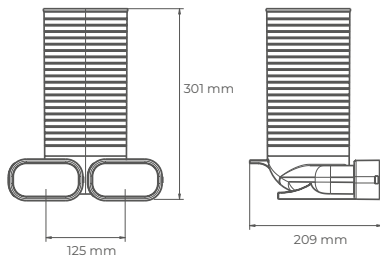

A	301 [mm]			
B	≥ 100 [mm]			
C	DN 125 [mm]			
Zeta [-]	1,08	0,84	1,29	1,52
Qv [m³/h]	Δp [Pa]			
1x10 2x5	0,5	0,1	0,6	0,2
1x20 2x10	2,2	0,4	2,6	0,8
1x30 2x15	4,9	0,9	5,8	1,7
1x40 2x20	8,7	1,7	10,4	3,1
1x50 2x25	13,6	2,6	16,2	4,8
1x60 2x30	19,5	3,8	23,3	6,9



LowAir room plenum

Wall/ceiling supply or exhaust room plenum with 1 plug-in connection for LowAir ducting. Made of pre-painted black galvanized steel plate, it is equipped with adjustable fixing brackets. It can house the filter and it is suitable for RDZ air grilles. Nominal air flow rate from 25 to 90 m³/h.

CONNECT.	PLENUM SIZE l x h x d	GRILLE SIZE l x h	NUM. SPIGOTS	PACK.	CODE
side entry	220x137x102 mm	200x100 mm	1	1 item	70PA02010L100
side entry	320x137x102 mm	300x100 mm	2	1 item	70PA03010L200
rear entry	220x120x102 mm	200x100 mm	1	1 item	70PA02010P100
rear entry	320x120x102 mm	300x100 mm	2	1 item	70PA03010P200

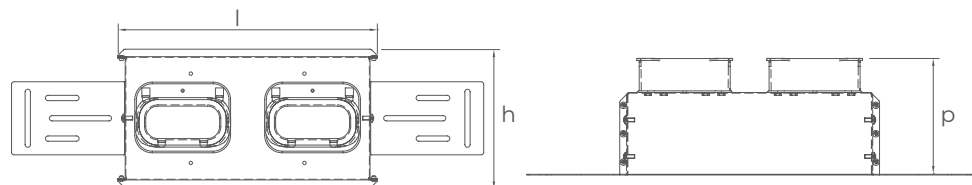

■ VENTILATION AIR GRILLES FOR LOWAIR

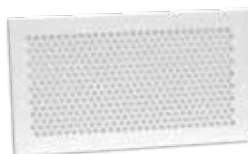

Design Air Grille - Round pattern

White RAL 9016 grille designed for easy installation and maintenance. Finishing with round pattern. Magnetic fixing.

ROOM PLENUM	EXTERNAL SIZE l x h	PACK.	CODE
1 outlet	230x130 mm	1 item	7045081
2 outlets	330x130 mm	1 item	7045086



Design Air Grille - Line pattern

White RAL 9016 grille designed for easy installation and maintenance. Finishing with horizontal blades. Magnetic fixing.

ROOM PLENUM	EXTERNAL SIZE l x h	PACK.	CODE
1 outlet	230x130 mm	1 item	7045082
2 outlets	330x130 mm	1 item	7045087



Design Air Grille - Axis pattern

White RAL 9016 grille designed for easy installation and maintenance. Finishing with vertical blades. Magnetic fixing.

ROOM PLENUM	EXTERNAL SIZE l x h	PACK.	CODE
1 outlet	230x130 mm	1 item	7045083
2 outlets	330x130 mm	1 item	7045088

Air grille 400X100 Univ. Ø 100

White aluminium duct terminal for the supply or exhaust of room air. It is equipped with air grille (430x130 mm) with fixed horizontal fins, 0° deflection angle, 12.5 mm blade pitch. It also includes a contrast control damper.



SIZE l x h x d	PACK.	CODE
396x96x200 mm	1 item	7045098

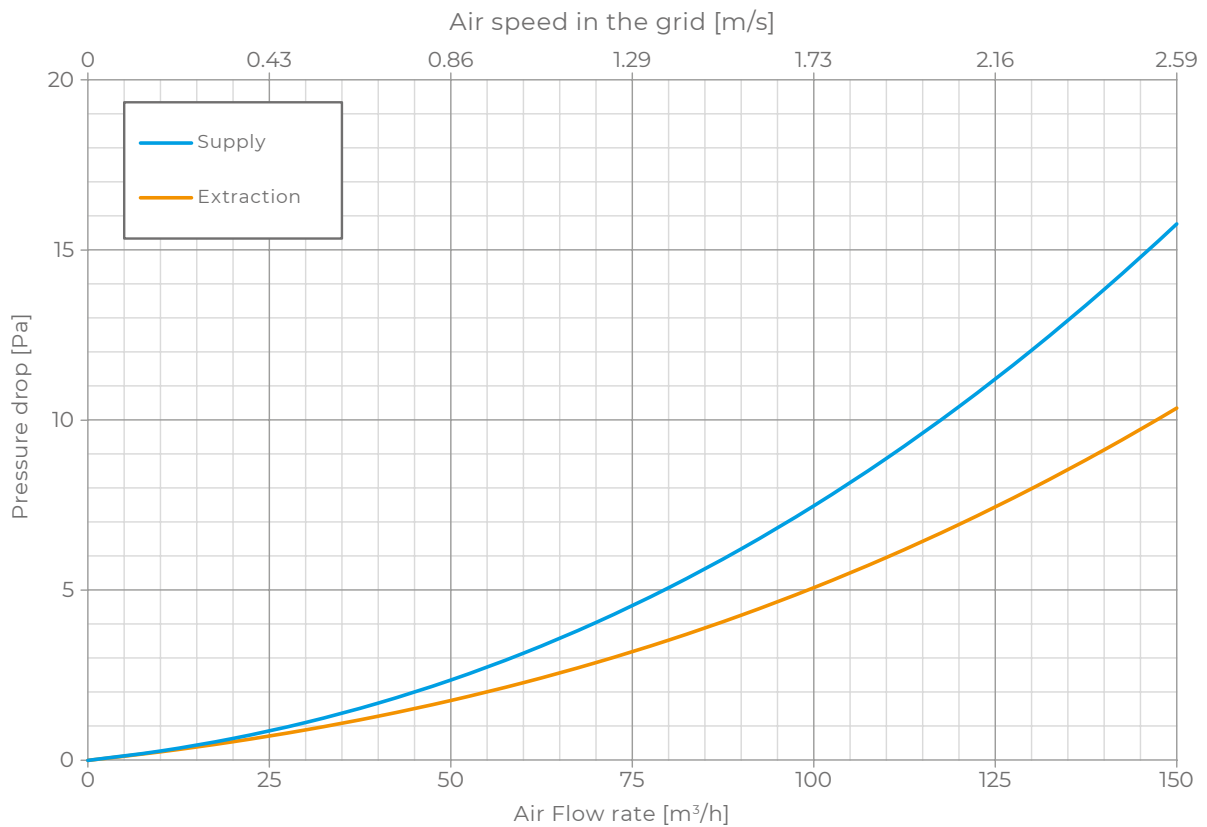
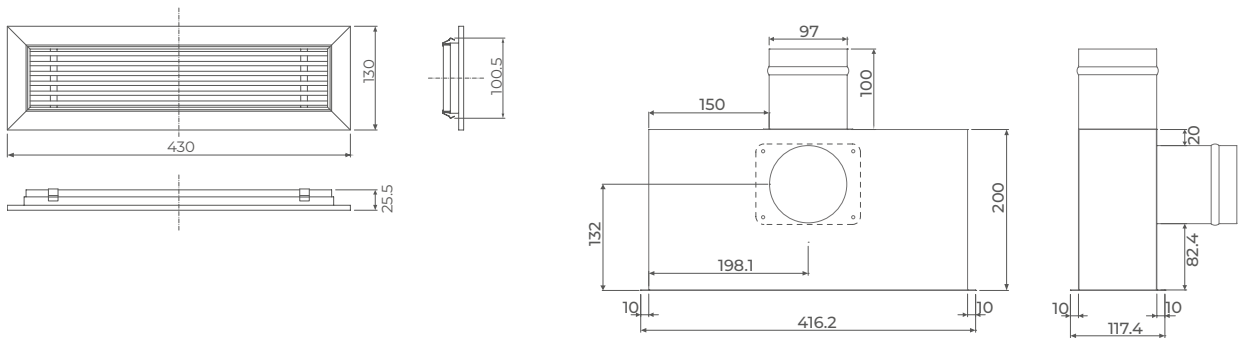



Air grille 300X200 Univ. Ø 160

White aluminium duct terminal for the supply or exhaust of room air. It is equipped with air grille (330x230 mm) with fixed horizontal fins, 0° deflection angle, 12.5 mm blade pitch. It is available either with rear entry or side entry DN 160.

SIZE l x h x d	PACK.	CODE
296x196x200 mm	1 item	7045099

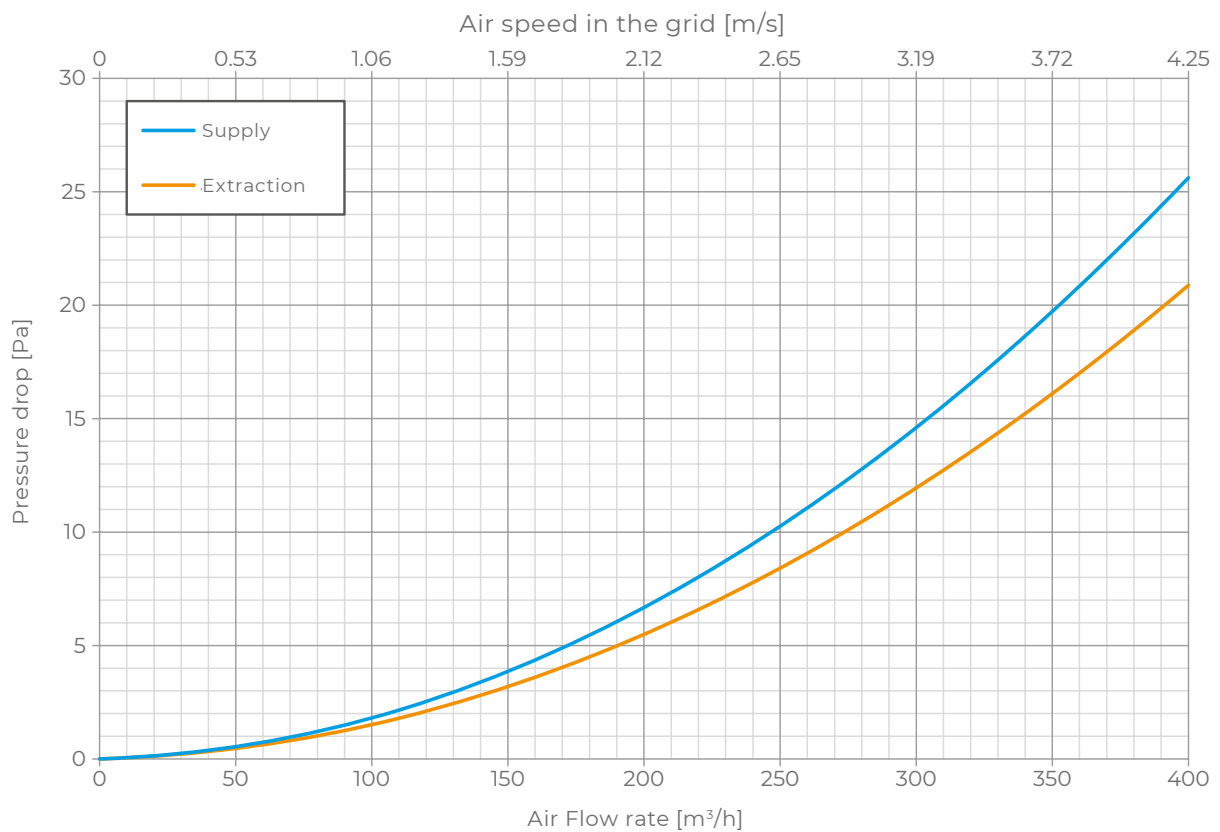
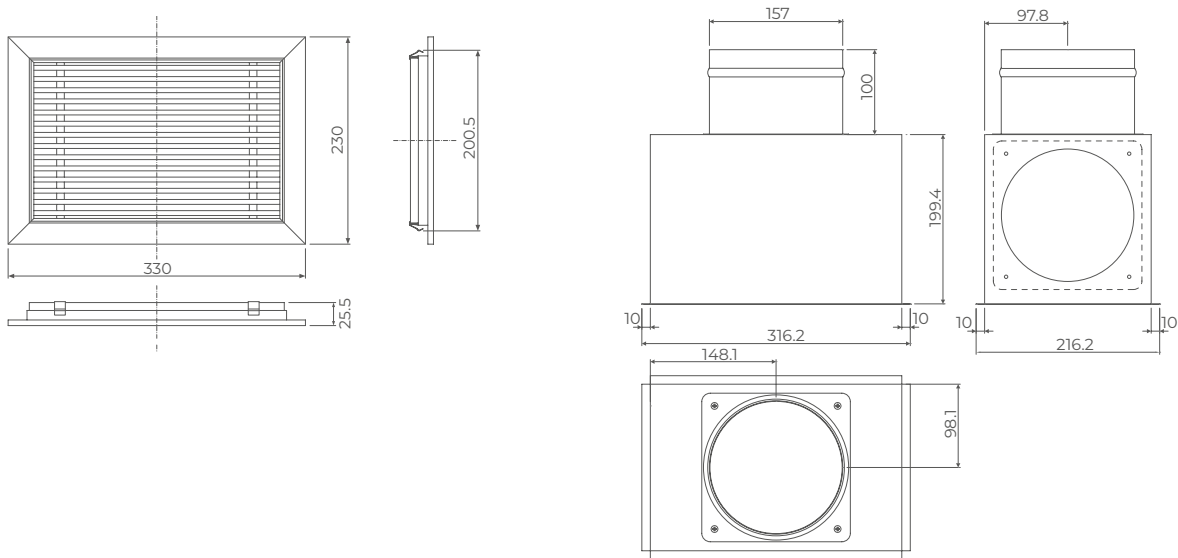



Borea Air Valve

Duct terminal for the supply or exhaust of room air, made of plastic material, consisting of a central rotating plate and adjustable grille for air flow calibration. It is suitable for ceiling or wall installation and for limited flow rate.

ØD1	ØD2	HMIN	HMAX	PACK.	CODE
119 mm	165 mm	12 mm	24 mm	1 item	7045155

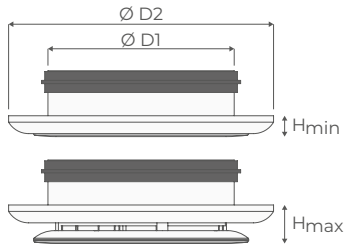

Extract Air Valve

RAL 9016 adjustable extract air valve with clamps to facilitate installation in the adapter and removal for cleaning. It is suitable for ceiling or wall installation.

Ø	EXTERNAL SIZE Ø	PACK.	CODE
125 mm	150x31 mm	1 item	7046145

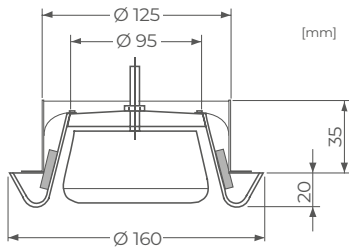

Supply Air Valve

RAL 9016 adjustable supply air valve with clamps to facilitate installation in the adapter and removal for cleaning. It is suitable for ceiling or wall installation.

Ø	EXTERNAL SIZE Ø	PACK.	CODE
125 mm	155x40 mm	1 item	7046150

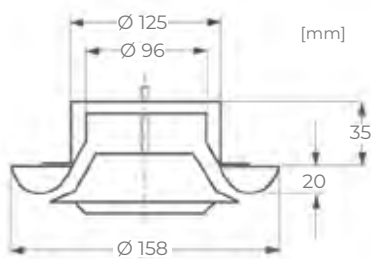



Circle Air Valve

Plastic air valve for air supply or air extract, equipped with bayonet flange.

Ø	EXTERNAL SIZE Ø	PACK.	CODE
125 mm	170x20 mm	1 item	7045156

Supply air

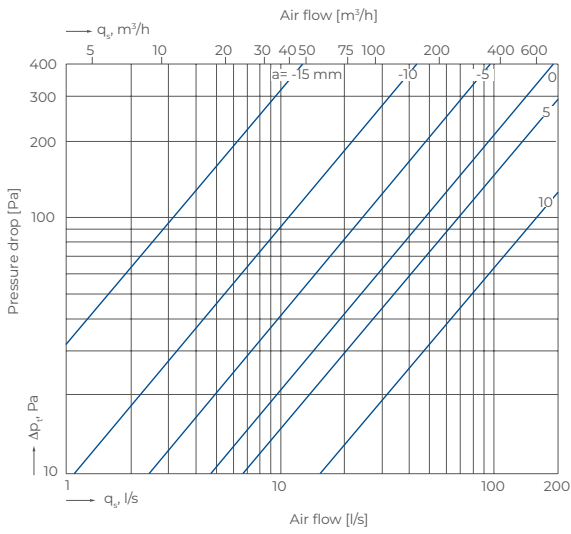

Stale air extraction

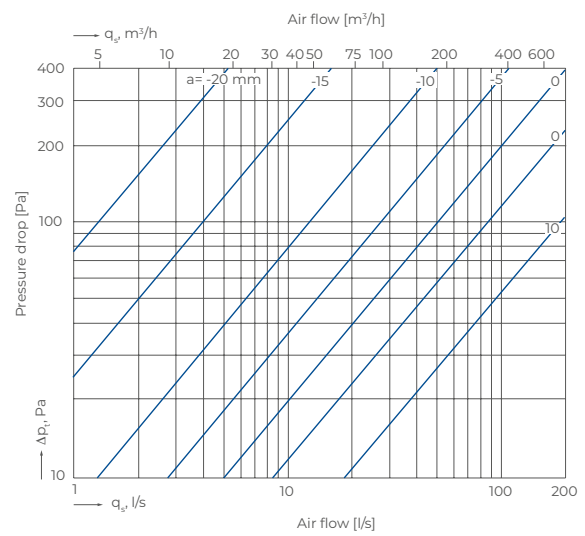

Flat Air Valve

Air supply or extract valve for ceiling or wall installation. Body and front panel in RAL 9010 painted steel.

Ø	EXTERNAL SIZE Ø	PACK.	CODE
125 mm	165x165x20 mm	1 item	7045157

Supply air

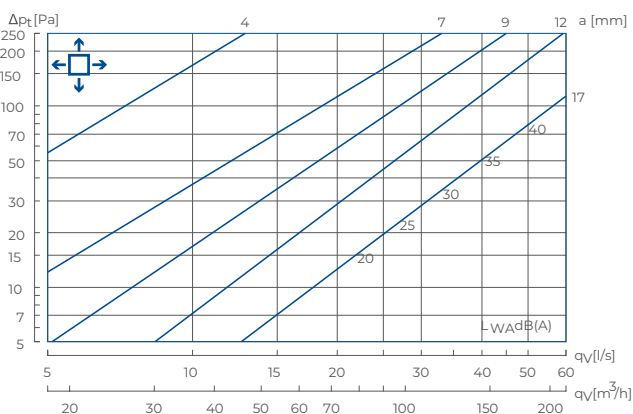

Stale air extraction

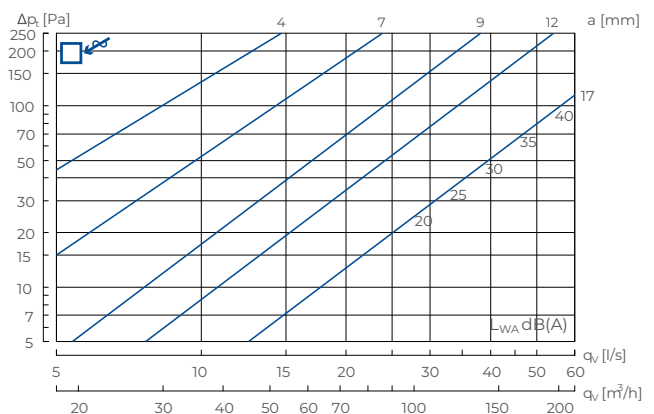



Round Aluminium Outdoor Vent

Round outdoor ventilation grille in die-cast aluminium. Equipped with removable wire mesh.

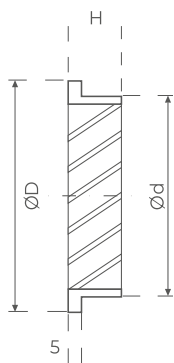

Ød	ØD	H	PACK.	CODE
125 mm	150x5 mm	20 mm	1 item	7046370
160 mm	185x5 mm	20 mm	1 item	7046371
200 mm	225x5 mm	20 mm	1 item	7046372



Round Vent Grille

Round ABS ventilation grille with spring and removable wire mesh.

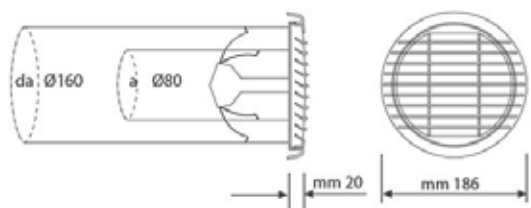

Ø	EXTERNAL SIZE Ø	PACK.	CODE
100-160 mm	190x25 mm	1 item	7045108

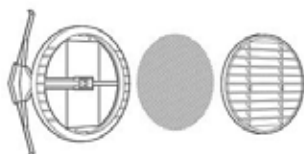

Stainless Steel Outdoor Vent



External ventilation grille for air intake or air exhaust, made of stainless steel with cowl.

DN	EXTERNAL SIZE Ø	PACK.	CODE
125 mm	185x100 mm	1 item	7045145
160 mm	210x115 mm	1 item	7045151
200 mm	275x135 mm	1 item	7045109

External Grille



Outdoor ventilation grille for air intake or air exhaust.

DN	l	h	p	d	CODE
125 mm	233 mm	242 mm	194 mm	110 mm	7046281
160 mm	233 mm	242 mm	194 mm	110 mm	7046282

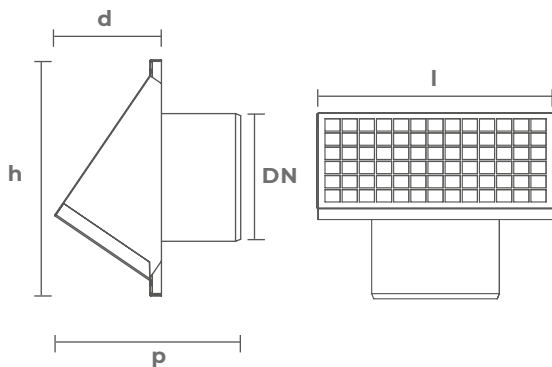

Pressure drop

m ³ /h	100	200	300	400	500	zeta
DN 125	8.0	32.0	71.9	127.9	199.8	2,60
DN 160	4.7	18.9	42.6	75.7	118.3	4,13
	ΔP[Pa]					[-]

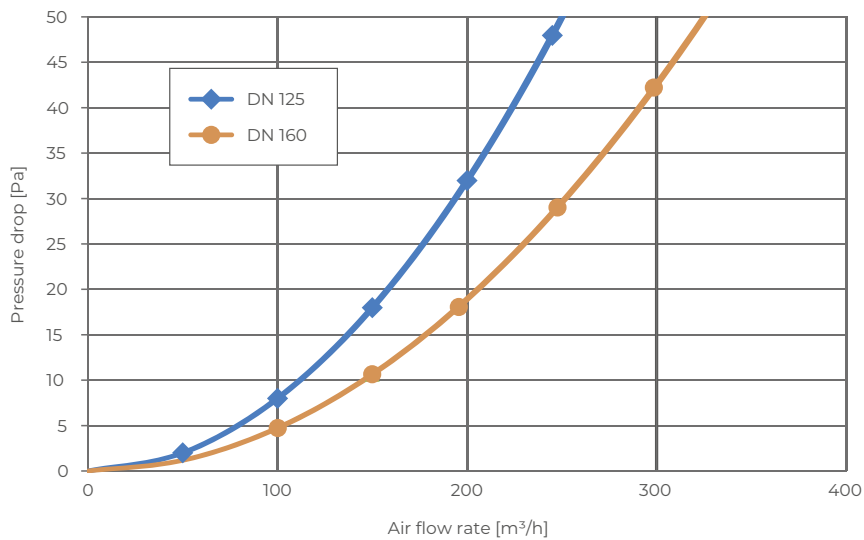

FILTER LIST FOR AIR HANDLING UNITS

Product	Model	Filter	Dimensions mm	Code
	WHR 62 PLUS	4 filters ISO Coarse 50%	DN 160	7044101
	SERIE REFLAIR	2 filters ISO Coarse 65% (G4) 2 filters ISO ePM1 60% (F7)	200X165X45 200X165X45	70RFLG4000 70RFLF7000
	CHR 400	1 filter ISO Coarse 50% (G2) 1 filter ISO ePM10 65% (M5) 1 filter ISO Coarse 65% (G4)	255X165X10 255X165X47 255X165X25	7044105
	WHR 150	2 filters ISO ePM10 50%	190x220x25	7044111
	WHR 400	2 filters ISO ePM1 70%	190x220x25	7044115
	WHRI 150	2 filters ISO ePM1 70%	175x167x25	7044120
	WHRI 220	2 filters ISO ePM1 70%	195x222x25	7044125
	HR 90 500-800	1 filter ISO ePM1 70% (F7) 1 filter ISO ePM10 50% (M5)	470x350x48 470x350x48	7044193
	HR 90 1000-1200	1 filter ISO ePM1 70% (F7) 1 filter ISO ePM10 50% (M5)	600x450x48 600x450x48	7044194
	HR 90 1600-2200	1 filter ISO ePM1 70% (F7) 1 filter ISO ePM10 50% (M5)	625x500x48 625x500x48	7044195
	HR 90 3000	2 filters ISO ePM1 70% (F7) 2 filters ISO ePM10 50% (M5)	550x370x48 550x370x48	7044196
	HR 90 4000	2 filters ISO ePM1 70% (F7) 2 filters ISO ePM10 50% (M5)	600x450x48 600x450x48	7044197
	HR 90 5000	2 filters ISO ePM1 70% (F7) 2 filters ISO ePM10 50% (M5)	625x500x48 625x500x48	7044198
	HR 90 8000	3 filters ISO ePM1 70% (F7) 3 filters ISO ePM10 50% (M5)	625x500x48 625x500x48	7044199
	HR UA 800-1200	1 filter ISO ePM1 70% (F7) 1 filter ISO ePM10 50% (M5)	370x370x48 370x370x48	7044200
	HR UA 2200	1 filter ISO ePM1 70% (F7) 1 filter ISO ePM10 50% (M5)	600x450x48 600x450x48	7044202
	HR UA 3000	2 filters ISO ePM1 70% (F7) 2 filters ISO ePM10 50% (M5)	550x370x48 550x370x48	7044203
	RNW 200 P-200 PI	1 filter ISO Coarse 40%	460x320x10	7044130
	RNW 404-411	1 filter ISO Coarse 40%	448x197x10	7044135
	RNW 508	1 filter ISO Coarse 40%	506x246x10	7044138
	DA 701	1 filter ISO Coarse 60%	605x296x50	7044175
	DA 1001	1 filter ISO Coarse 60%	713x346x50	7044180
	DA 2001	1 filter ISO Coarse 60%	815x535x50	7044185
	UAP 201-PDC	3 filters ISO ePM10 50%	200x200x48	7044145
	UC 300 V2	3 filters ISO Coarse 60%	255x142x10	7044150
	UC 360 V1	1 filter ISO Coarse 65% 1 filter ISO Coarse 65% 1 filter ISO Coarse 65%	213x205x30 113x200x30 333x200x30	7044155
	UC 501-MHE	1 filter ISO Coarse 65% 1 filter ISO Coarse 65% 1 filter ISO Coarse 65%	213x205x30 113x200x30 333x200x30	7044165
	UC 500-MVHE	1 filter ISO Coarse 60% (G3) 1 filter ISO Coarse 60% (G3) 1 filter ISO Coarse 60% (G3)	160x360x100 180x360x50 180x360x50	7044170
		1 filter ISO Coarse 65% (G4) 1 filter ISO Coarse 65% (G4) 1 filter ISO Coarse 65% (G4)	160x360x100 180x360x50 180x360x50	7044171
		1 filter ISO Coarse 50% 1 filter ISO Coarse 50%	612x346x50 396x346x50	7044190
	SR 1001	1 filter ISO Coarse 50% 1 filter ISO Coarse 50%	716x346x50 496x346x50	7044191
	SR 2001	1 filter ISO Coarse 50% 1 filter ISO Coarse 50%	890x490x50 600x490x50	7044192



SYSTEM LAYOUT WITH RNW 411 AND WHR 62 PLUS

The diagram shows a heating and cooling system with FLOOR split heat pump and domestic hot water production in a 200-liter technical tank with instantaneous exchange and internal coil. On the system side there is a manifold with separator function combining a GM PF-CF mixing group to serve a radiant system in winter and summer, and a GR direct supply unit to serve the RNW 411 unit for dehumidification and integration. Air exchange is achieved with WHR 62 wall-mounted heat recovery units.

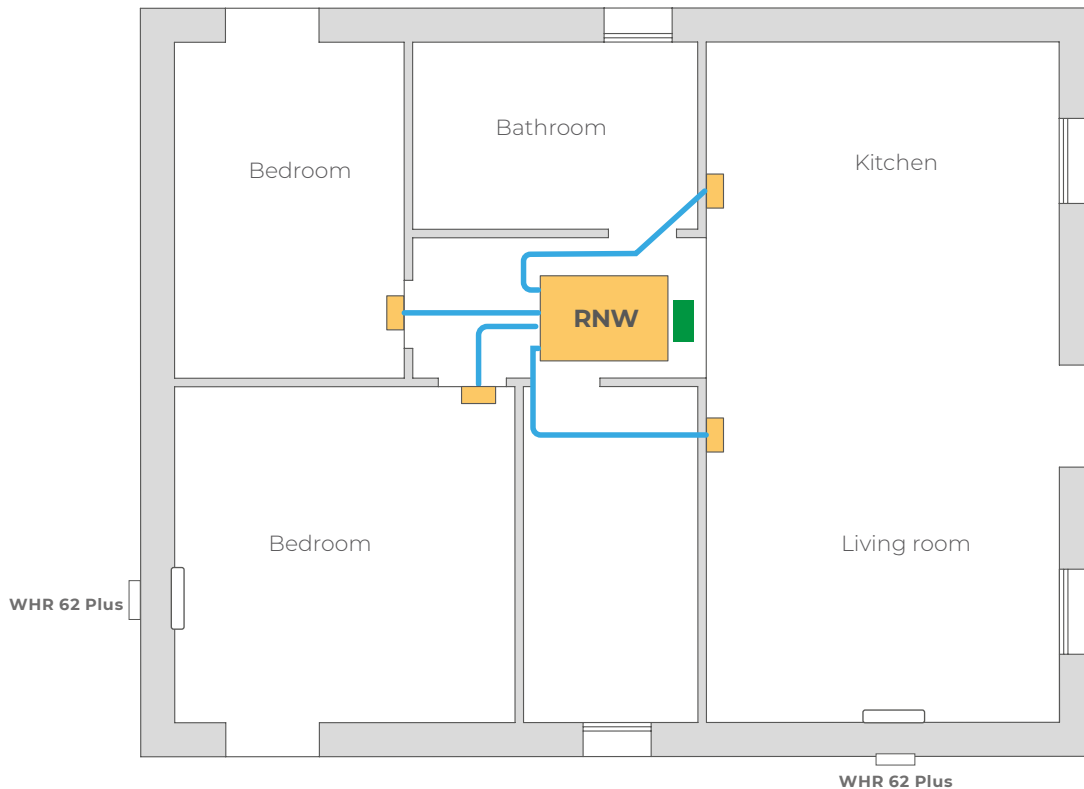
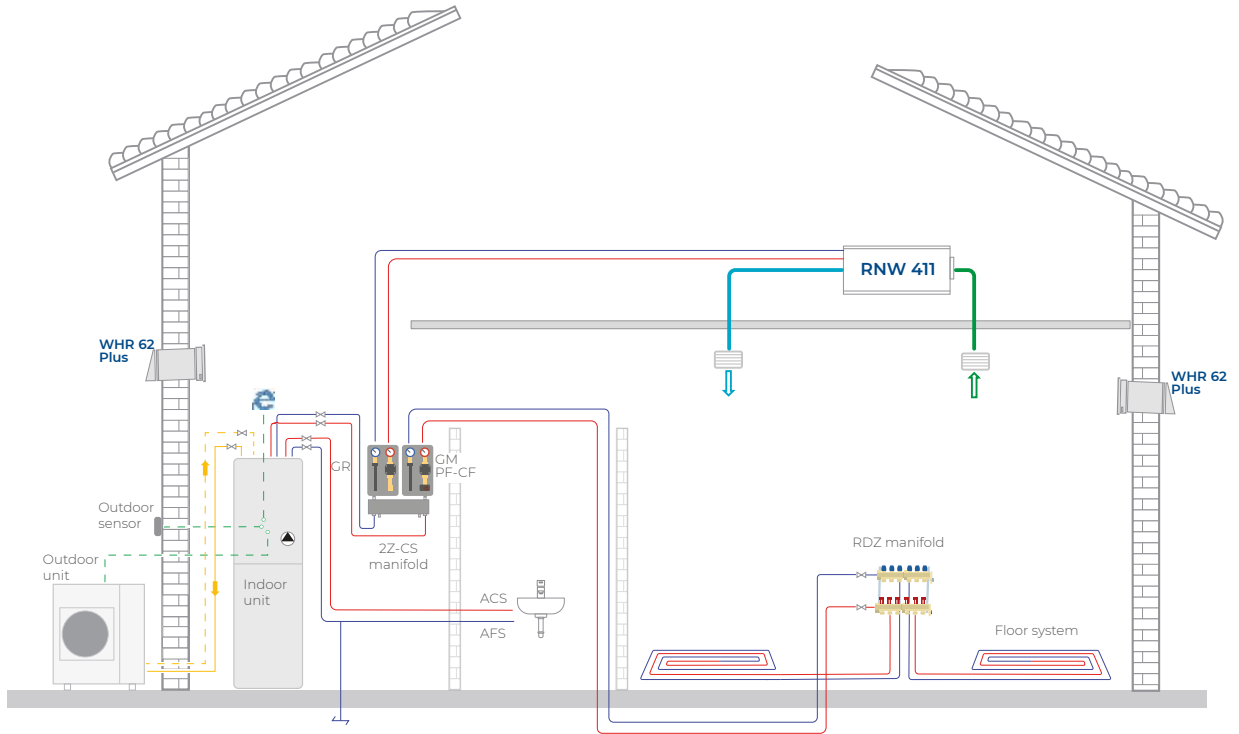

SYSTEM LAYOUT WITH REFLAIR 250 AND DWF 200

The diagram shows a heating and cooling system with FLOOR split heat pump and domestic hot water production in a 200-liter technical tank with instantaneous exchange and internal coil. On the system side there is a manifold with separator function combining a GM VJ mixing group to serve the radiant system, and a GR direct supply unit to serve the air handling unit consisting of the DWF 200 dehumidification module and the high-efficiency REFLAIR 250 heat recovery unit.

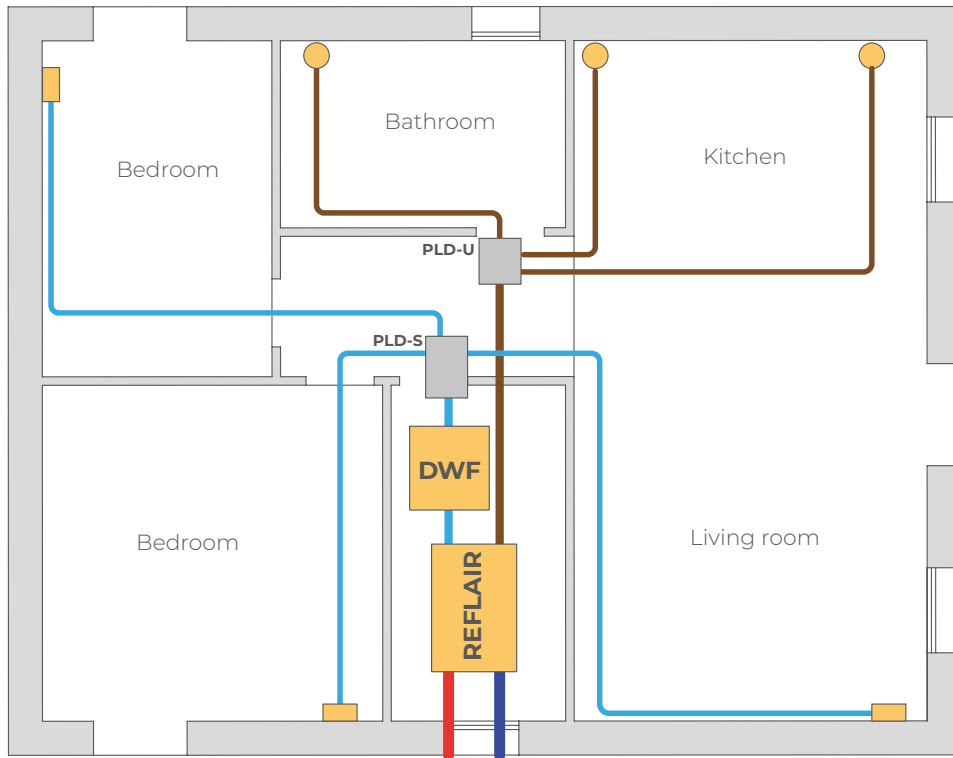
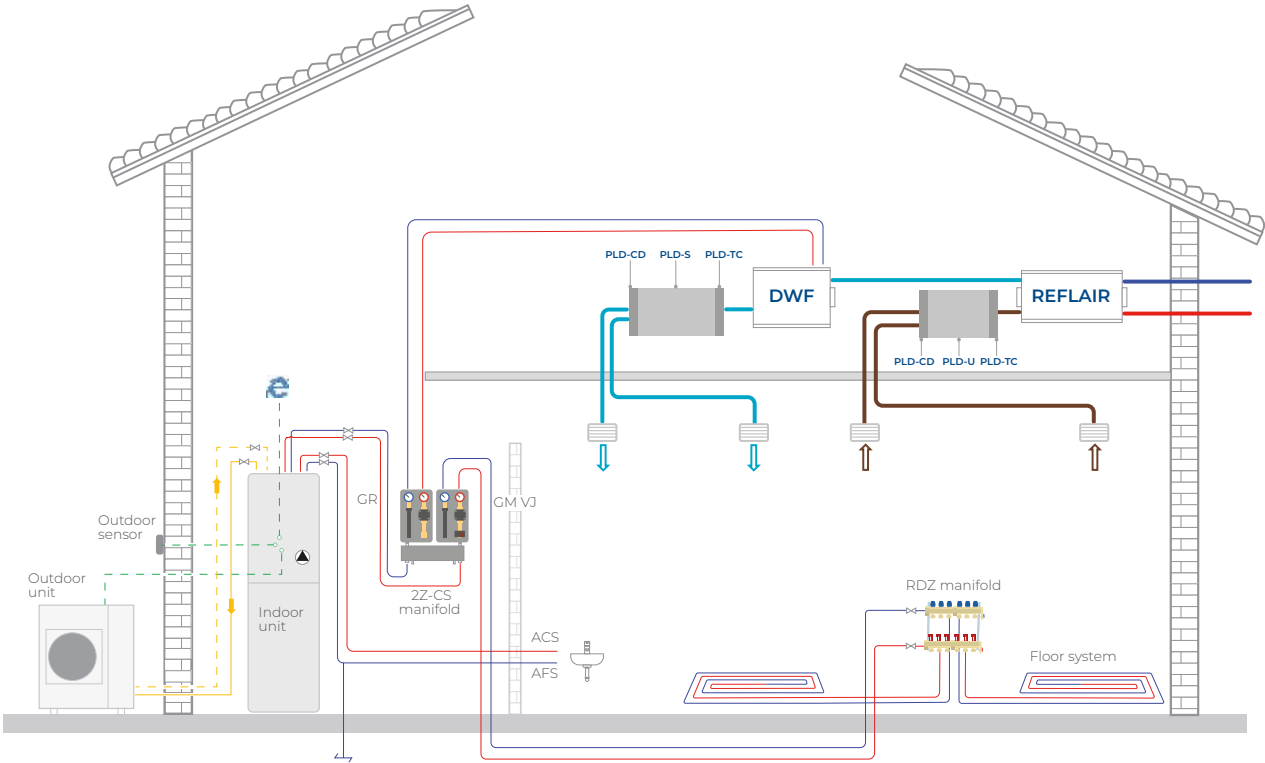

SYSTEM LAYOUT WITH UC

The diagram shows a heating and cooling system with FLOOR split heat pump and domestic hot water production in a 200-liter technical tank with instantaneous exchange and internal coil. On the system side there is a manifold with separator function combining a GM VJ mixing group to serve the radiant system, and a GR direct supply unit to serve the air handling unit. Air exchange with heat recovery as well as summer dehumidification and integration are achieved by means of UC 300 V2 ceiling-mounted air handling unit.

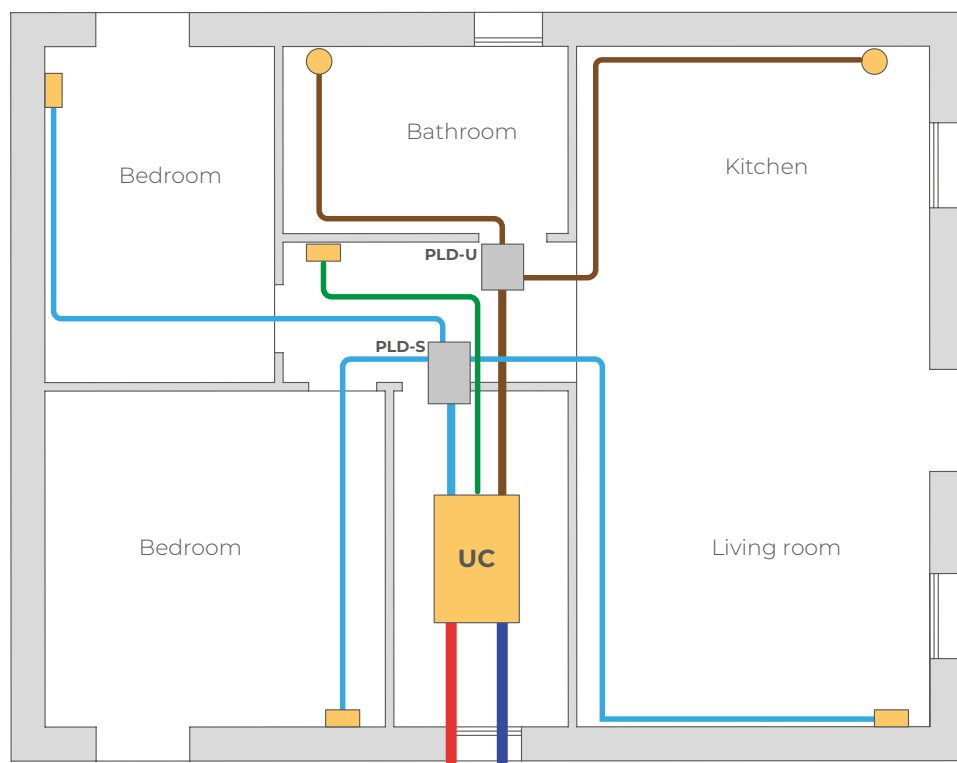
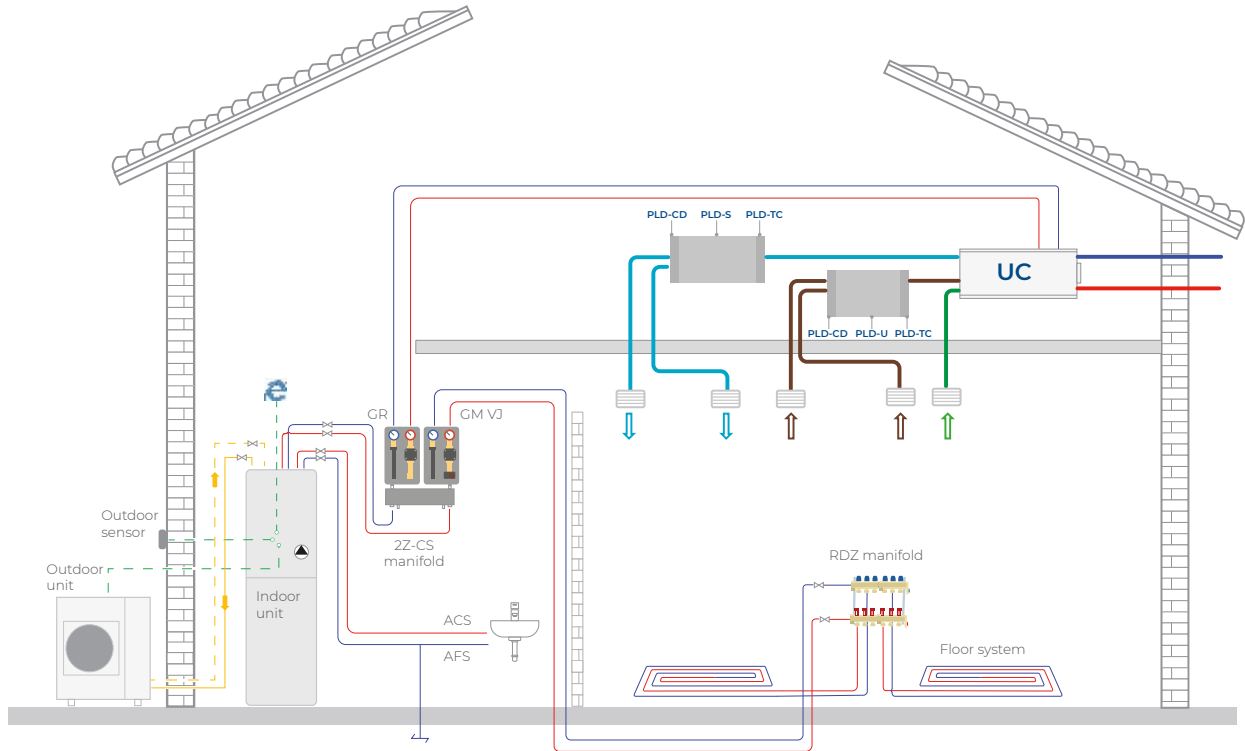

SYSTEM LAYOUT WITH UAP

The diagram shows a heating and cooling system with FLOOR split heat pump and domestic hot water production in a 200-liter technical tank with instantaneous exchange and internal coil. On the system side there is a manifold with separator function combining a GM VJ mixing group to serve the radiant system, and a GR direct supply unit to serve the air handling unit. Air exchange with heat recovery as well as summer dehumidification and integration are achieved by means of UAP 201-PDC ceiling-mounted air handling unit.

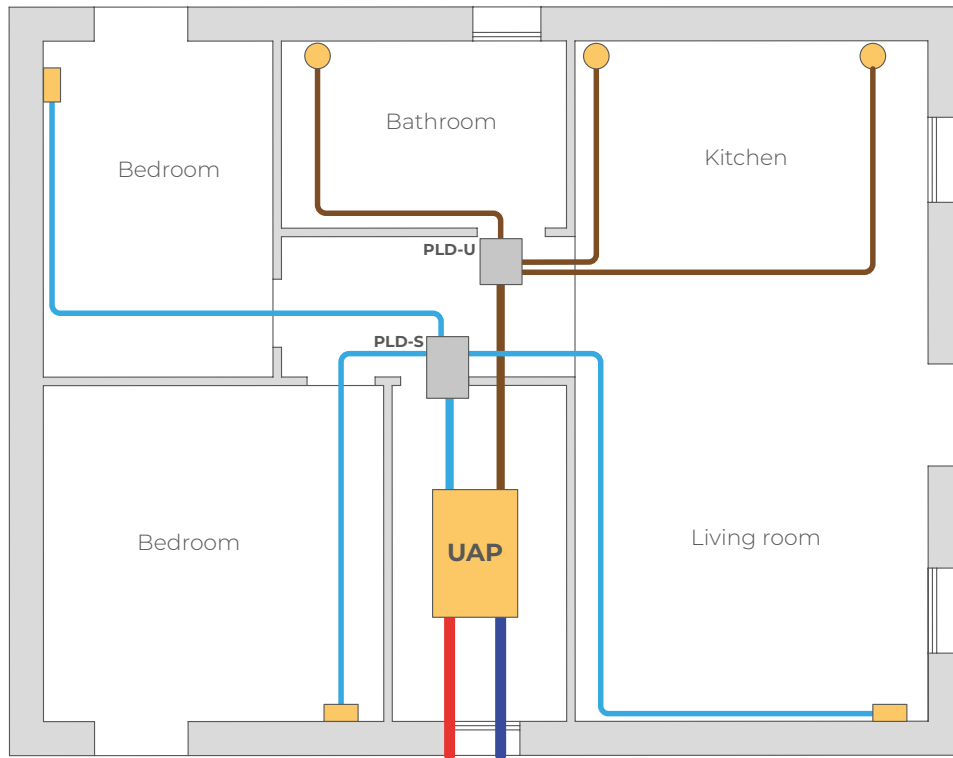
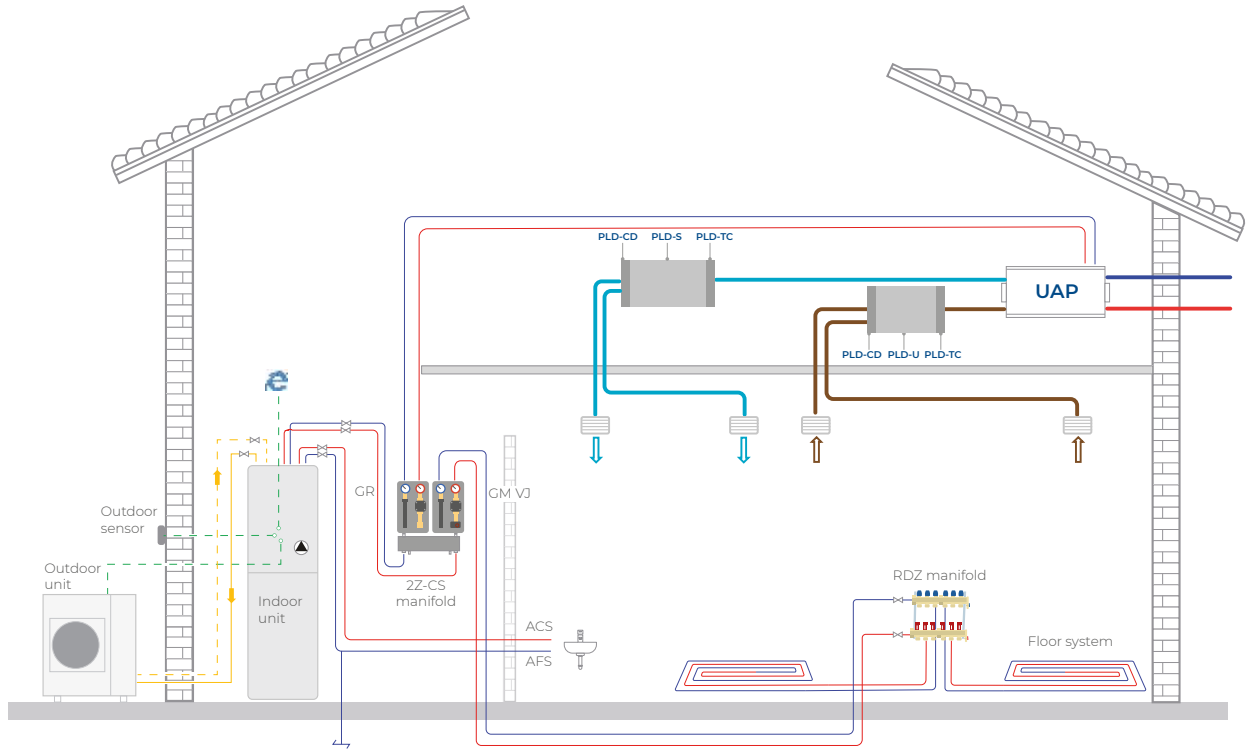

The proposed layouts are only indicative.

PSYCHROMETRIC DIAGRAM

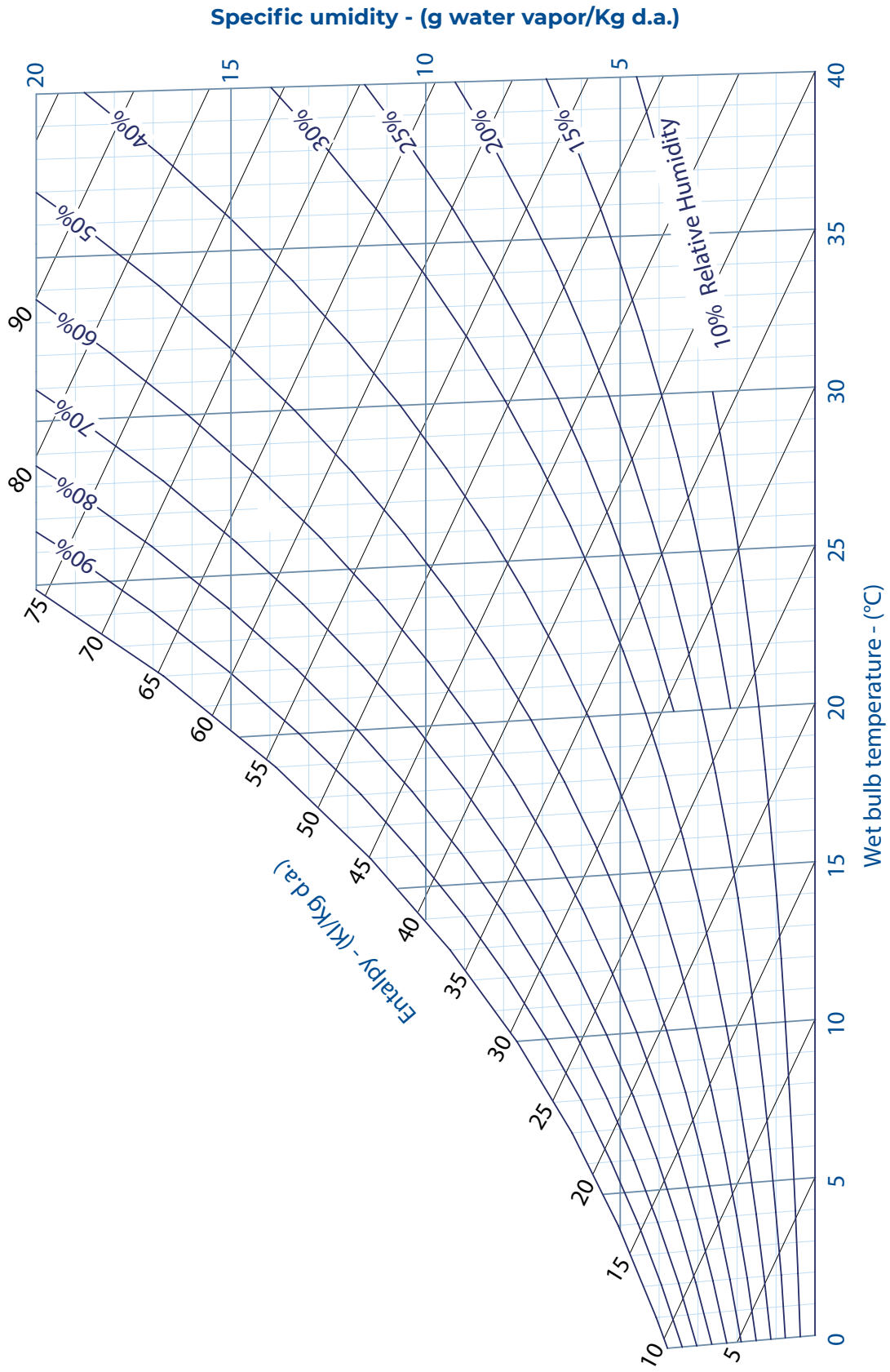

Our history



*For 45 years
we have been
a worldwide reference company
in the field of heating
and cooling systems.
We work with passion
to ensure indoor comfort
thanks to innovative solutions,
specifically for residential,
commercial and
industrial buildings.
We design and produce
high-efficient and
high-performance systems
which offer energy saving,
comfort and health
throughout the year.
Invisible solutions
spreading a unique sensation
of wellbeing in any room.*

 **RDZ**



